

SELECTIONS FROM
THE ART OF

S T R A N D I N G
D E A T H



THE ART OF

DEATH

STRANDING

TITAN BOOKS

Titan Books would like to thank the following people for their help and support in producing this book: Special thanks to Hideo Kojima, Shinji Hirano, Taro Yamashita, Yoji Shinkawa, and Ken Mendoza Hashimoto at KOJIMA PRODUCTIONS. Thanks also to all the artists whose work is featured in these pages; and to James Vance and Ashley Anne Gauer at KOJIMA PRODUCTIONS; and to Stephanie Fradue, Melanie Kwan, Tomoyo Kimura, Ryuhei Katami, Gerardo Riba, and David Bull at Sony Interactive Entertainment.

CONTENTS

4 Sam Bridges	40 Vehicles
8 Sam's Equipment	44 Weapons
14 Amelie	46 Structures & Mechs
16 Die-Hardman	48 Capital Knot
18 Deadman	50 Edge Knot
20 Heartman	52 Bridges Center
22 Mama	54 Mama's Lab
24 Fragile	56 Heartman's Lab
26 Higgs	58 MULE Camps
28 Clifford Unger	60 Waystations
30 Warriors WWII	62 Private Room
32 BT	

©2020 Sony Interactive Entertainment Inc. DEATH STRANDING is a trademark of Sony Interactive Entertainment LLC. Created and developed by KOJIMA PRODUCTIONS. Manufactured under license from Sony Interactive Entertainment LLC.

No part of this publication may be reproduced, stored in a retrieval system, or transmitted, in any form or by any means without the prior written permission of the publisher, nor be otherwise circulated in any form of binding or cover other than that in which it is published and without a similar condition being imposed on the subsequent purchaser.

Printed and bound in China.

SAM BRIDGES



THIS SPREAD / Early concepts for Sam's suit. At this stage, the concept was slightly more futuristic than the final.



CHARACTERS

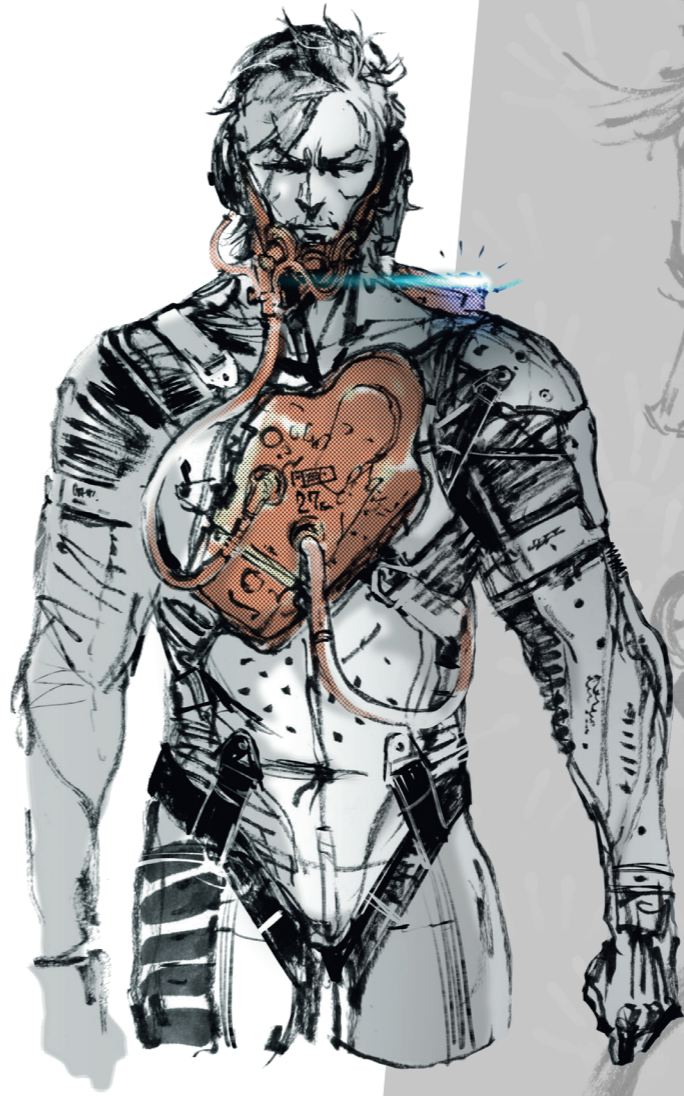

SAM BRIDGES





THIS PAGE / The final version of Sam's suit.



CHARACTERS

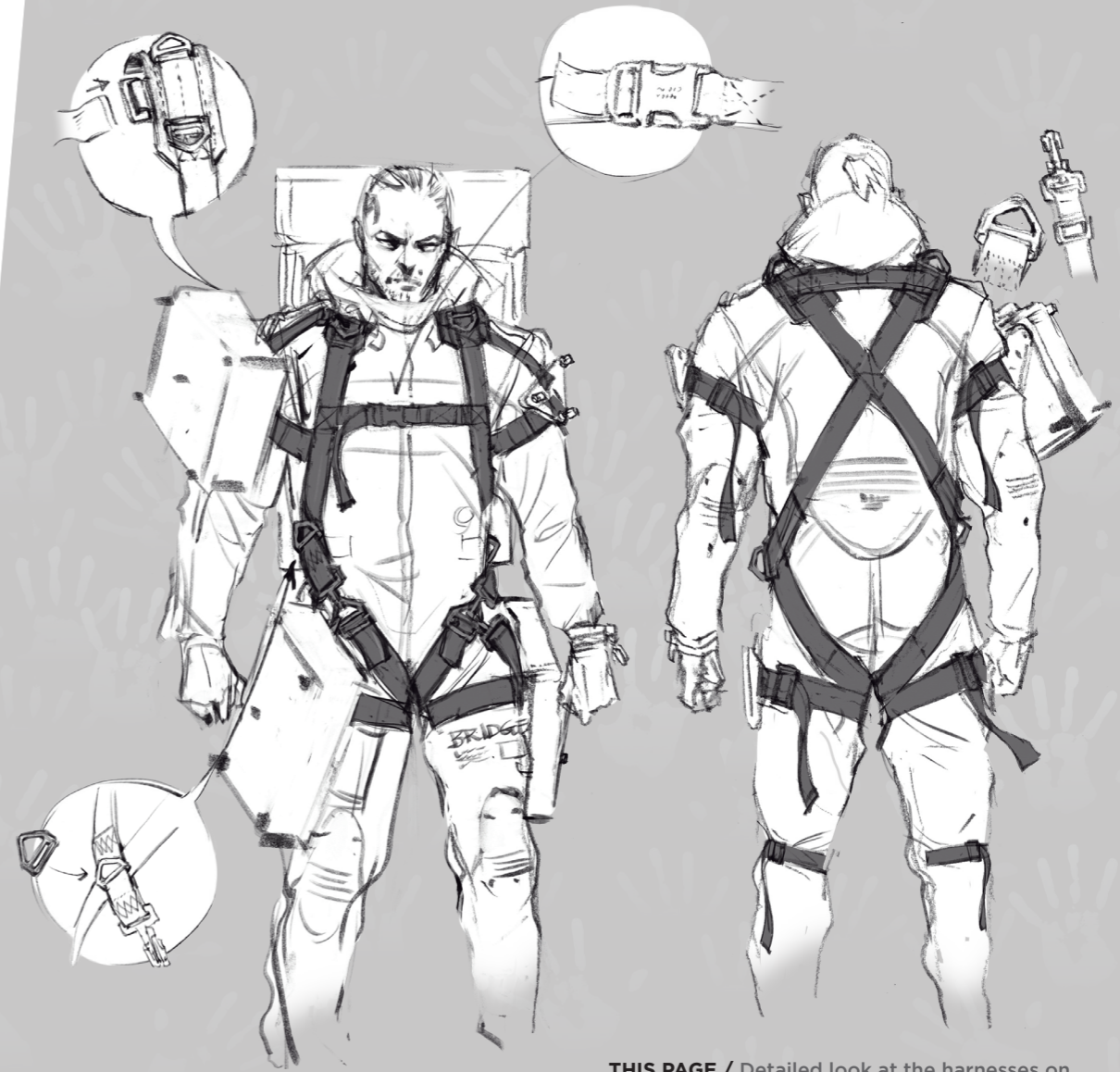

THIS PAGE / Detailed look at the harnesses on Sam's suit, which became the foundation for the different equipment Sam utilizes.



LEFT & BELOW /
Official Bridges boots. The idea was to create multi-purpose boots for trekking, as well as combat.



CHARACTERS

SAM'S EQUIPMENT

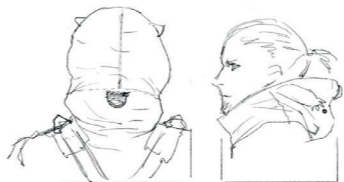

BELOW /
A visor for timefall, which automatically extends with the hood.



SAM'S EQUIPMENT

BELOW & RIGHT / Adding realistic details to accessories contributes to creating a more solidified vision of the world.

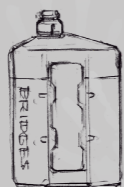
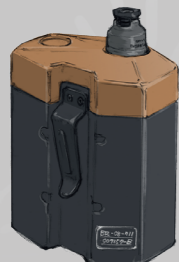

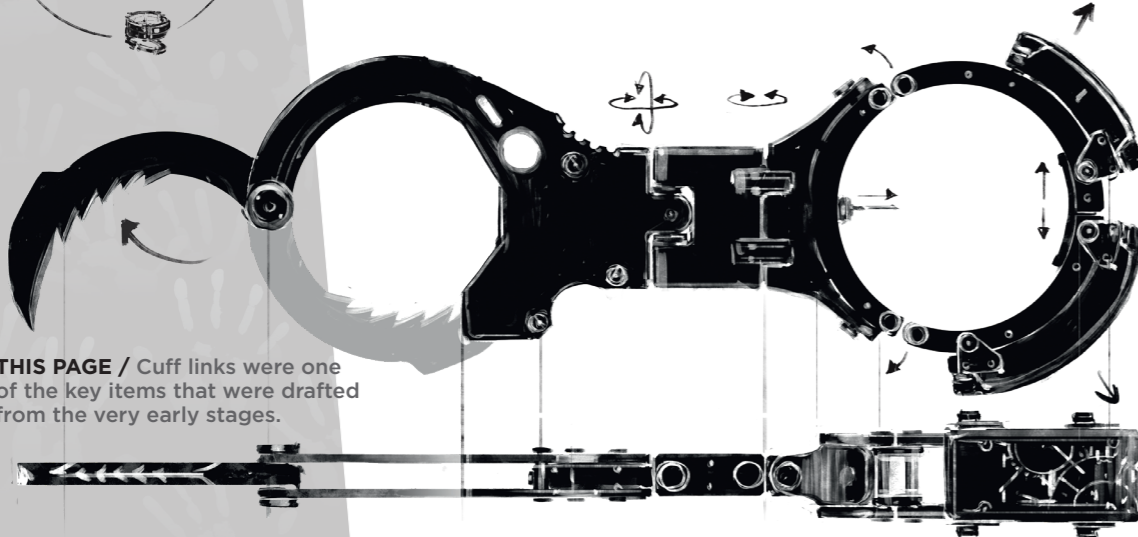
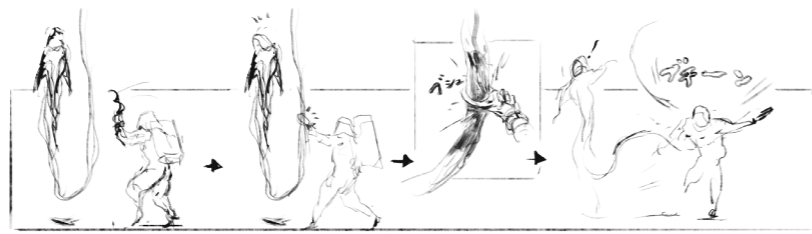
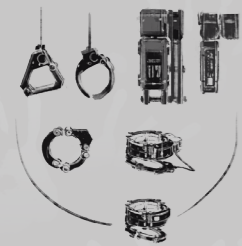

THIS PAGE / Cuff links were one of the key items that were drafted from the very early stages.

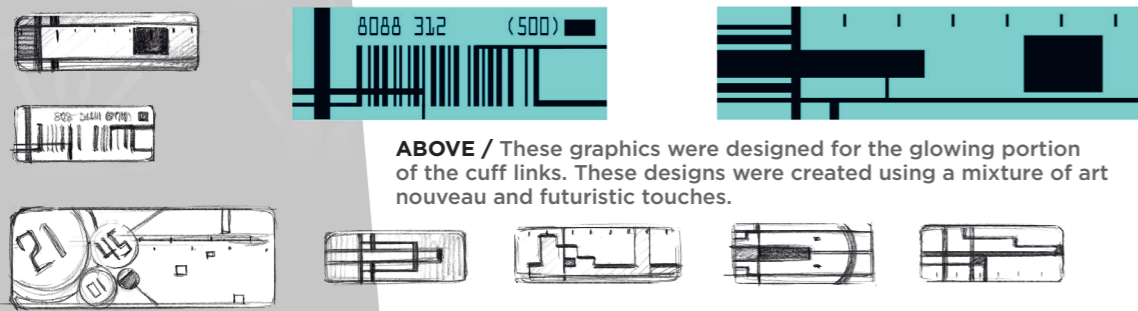

ABOVE / These graphics were designed for the glowing portion of the cuff links. These designs were created using a mixture of art nouveau and futuristic touches.

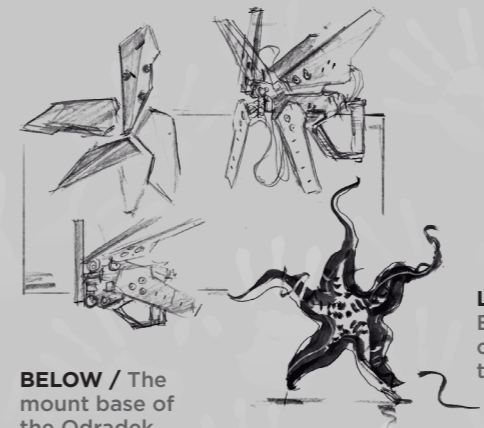

LEFT & RIGHT / Early and final concepts for the Odradek.

BELOW / The mount base of the Odradek, which is directly bolted onto Sam's suit.

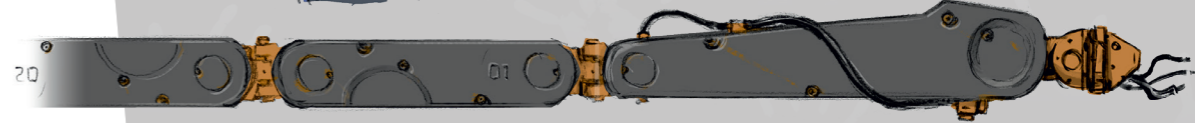
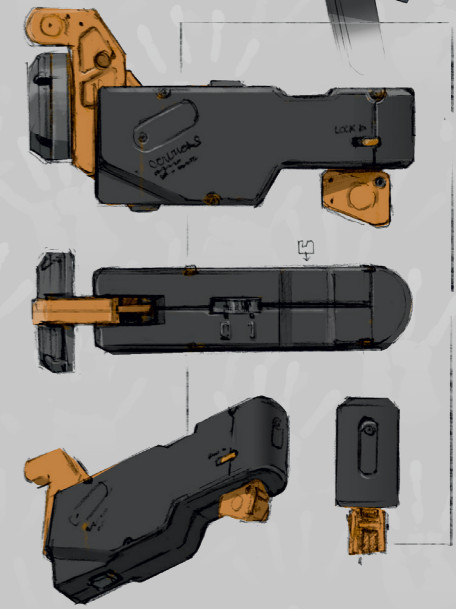
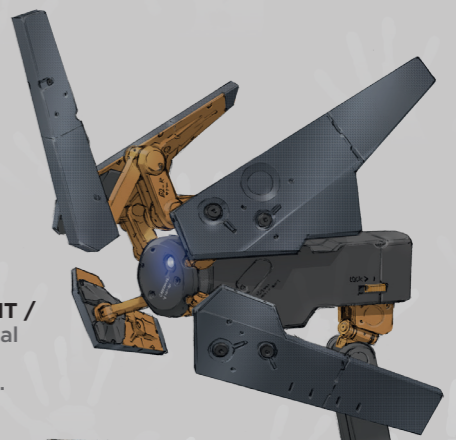



FAR LEFT & BELOW / Sam's shirt when indoors. The shirt was designed by Acronym. The pads in the back and shoulders serve to relieve stress on the body from cargo-carrying tasks.



CHARACTERS

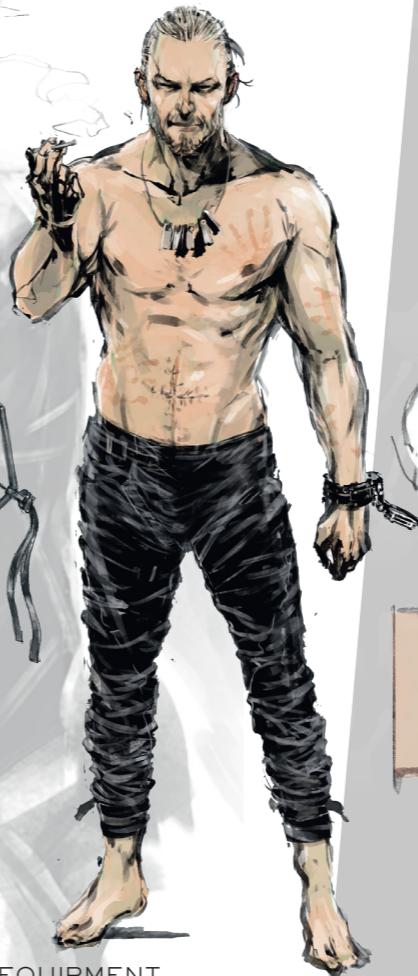

SAM'S EQUIPMENT

RIGHT / Concept for the handprint stencils found all over Sam's body.

BELOW / An early concept design for the blood extraction device used on Sam's body. This was eventually replaced with the cuff links, which also serve this purpose.

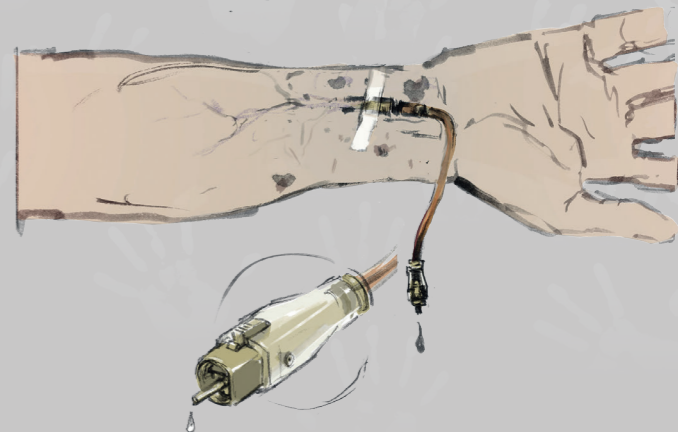



AMELIE



AMELIE

CHARACTERS



THIS SPREAD /
Early concepts for Amelie. After these, other directions were explored for this character. However, the final design ended up going back to these early concepts.

Amelie

AMELIE



LEFT & ABOVE / Final concepts for Die-Hardman. He is portrayed as a knowledgeable and mysterious character.



CHARACTERS

DIE-HARDMAN



LEFT & RIGHT / Early concepts for Die-Hardman. Originally he was envisioned as a tough-looking character covered in scars.

DIE-HARDMAN





DEADMAN



THIS PAGE /
The scars on his forehead are meant to add a Frankenstein's Monster-like feel to his character.





HEARTMAN

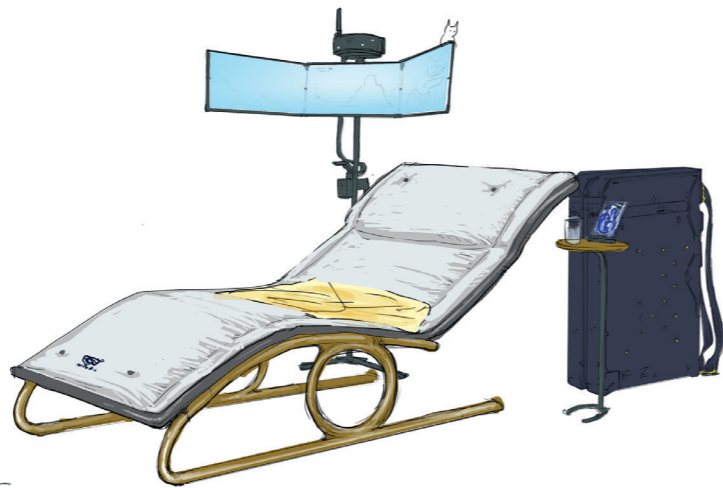

CHARACTERS

THIS SPREAD / Conceptualizing Heartman, as with some other characters, required starting from the uniqueness of an actual person and expanding from there to create the concept for the character, which proved to be a remarkably interesting task.



HEARTMAN

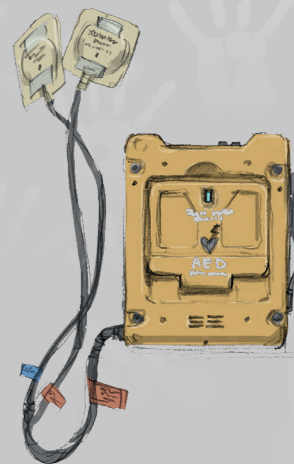
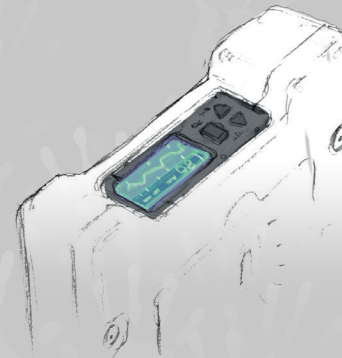
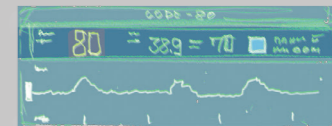



MAMA

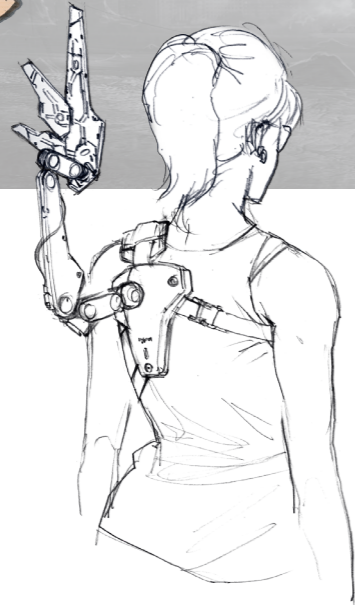

TOP / Final concept for Mama's Odradek, which has an angelic-wing shape when reacting to BTs.



LEFT / Near-final concept for Mama.

CHARACTERS



MAMA



RIGHT / Early concept for Mama.



LEFT / Final concept for Fragile.

FRAGILE



CHARACTERS

THIS PAGE /
Fragile's outfits
were made in
the spirit of
motorcycle gear.



FRAGILE





HIGGS



CHARACTERS

THIS PAGE & LEFT /
Close to final concepts.

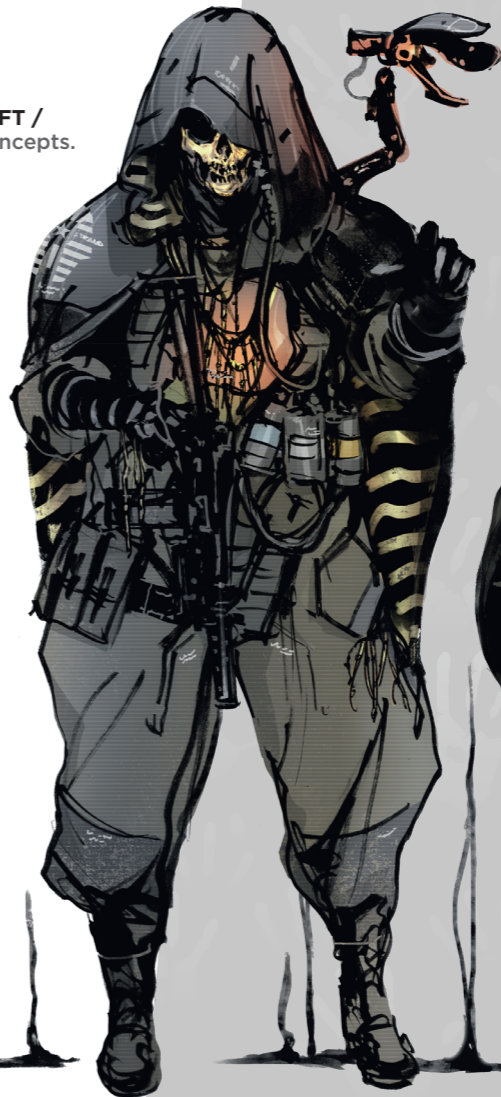

HIGGS

BELOW / Final concepts for Cliff and the Warriors.

CLIFFORD UNGER



LEFT & RIGHT / Concepts for Cliff during flashbacks.



RIGHT / Given Cliff's military background, service clothes were also sketched.



WARRIORS WWII



CHARACTERS

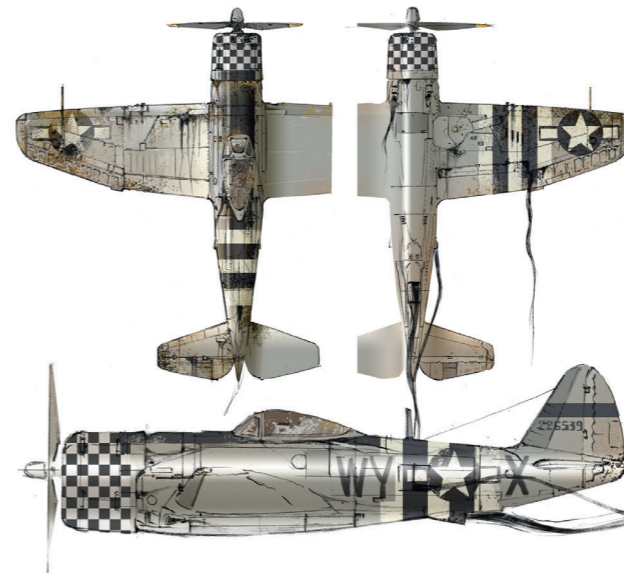

THIS SPREAD / Many of the WWII Warriors are from air forces. They have several umbilical cords hanging down, made from a dark, blood/tar-like substance.



WARRIORS WWII



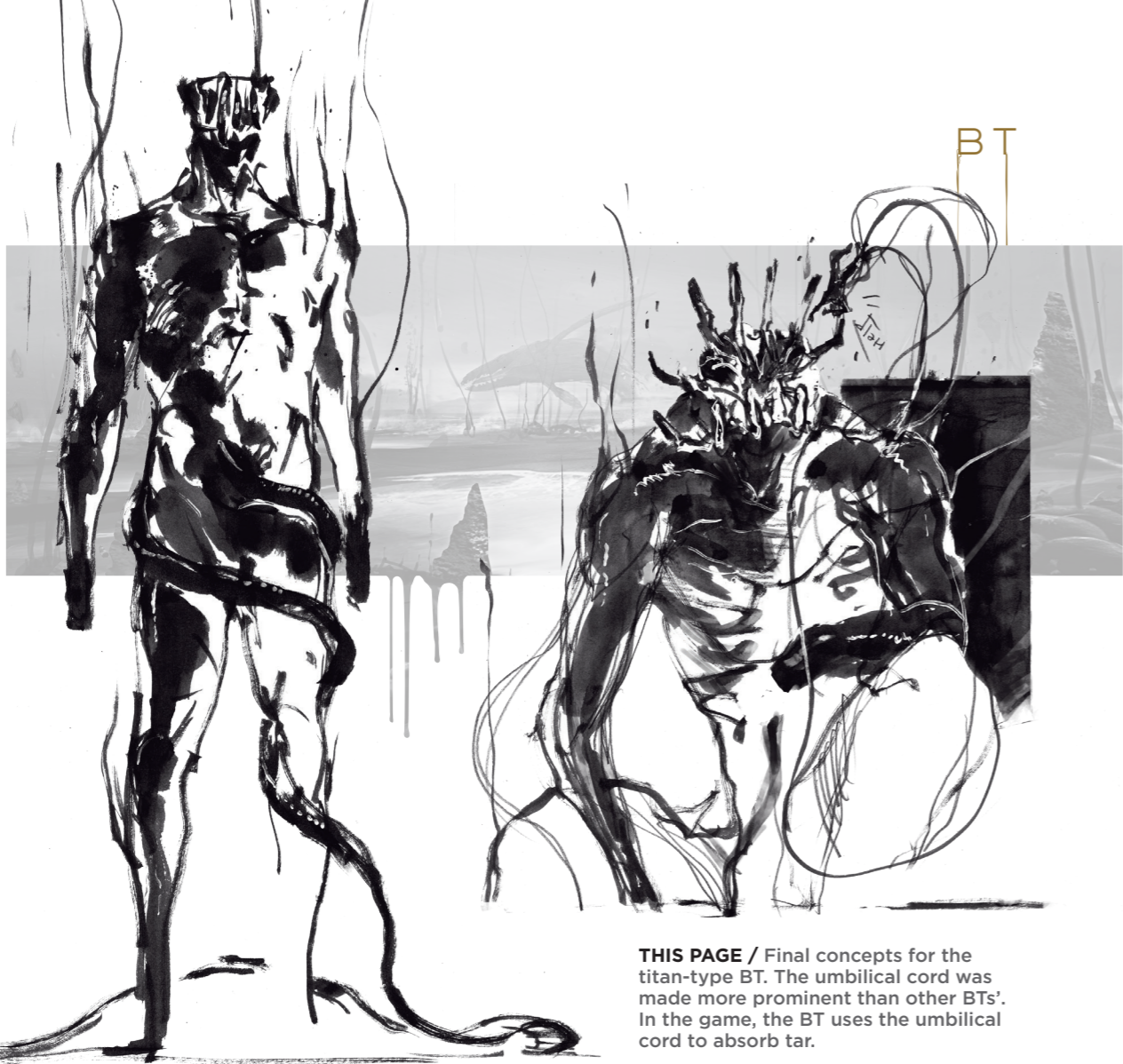

THIS PAGE / Final concepts for the titan-type BT. The umbilical cord was made more prominent than other BTs'. In the game, the BT uses the umbilical cord to absorb tar.



ABOVE / Early sketches of the titan-type BT.



THIS SPREAD / Feline-type BT. For BTs we wanted to have elements of stranded sea creatures, so even though this BT has feline-like elements, its texture and details are inspired by sea creatures. The tentacles in its head resemble the mane of a lion. A sea anemone-like mouth appears from under its golden mask.

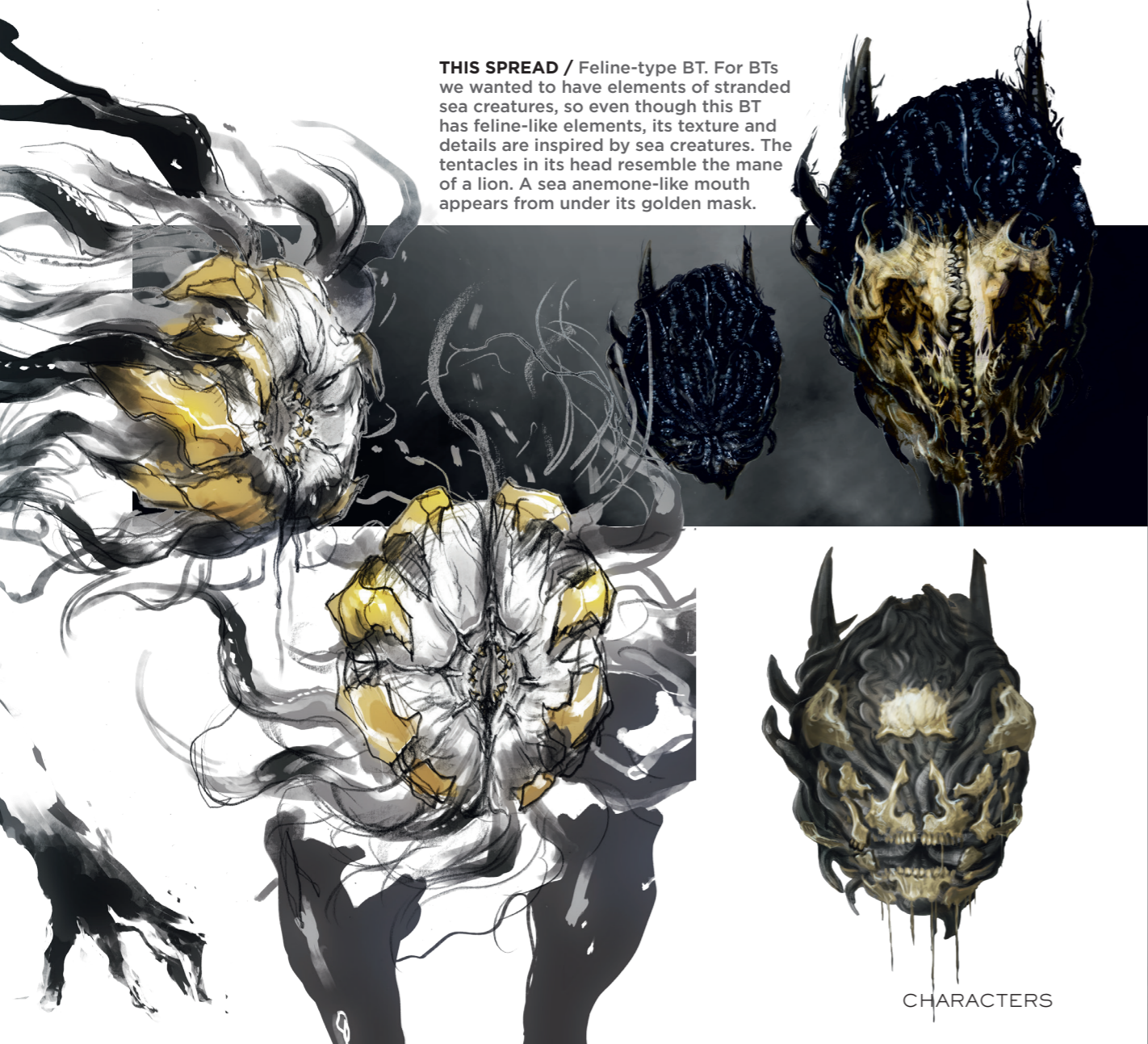

ABOVE / Different concepts for the feline-type BT's head.





THIS SPREAD / In parallel with conceiving the BTs themselves, ideas for how their attacks would look were also conceptualized.

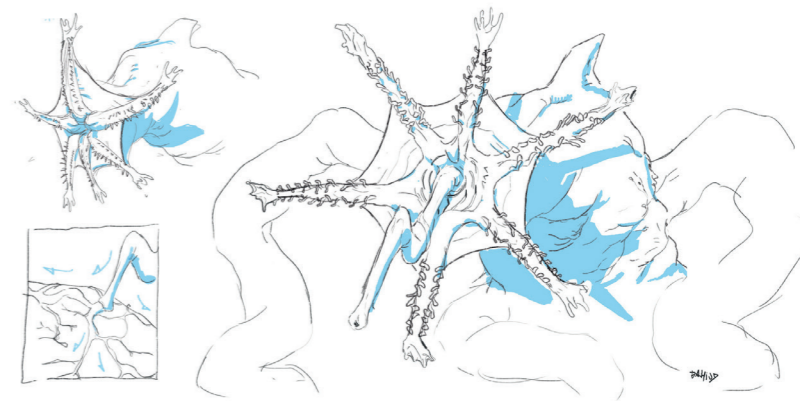

THIS SPREAD / Final concepts.



CHARACTERS



BT

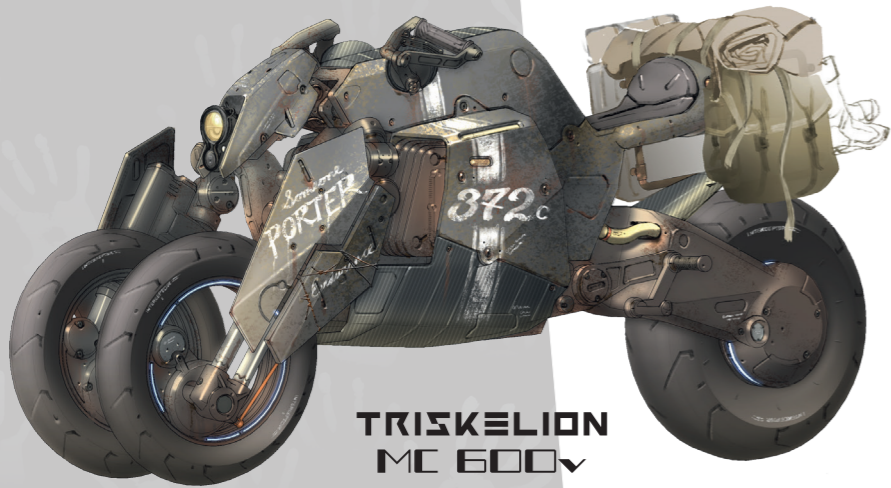

**TRISKELION
MC 600v**

THIS PAGE / Final concepts for the reverse trike.



CHARACTERS

VEHICLES

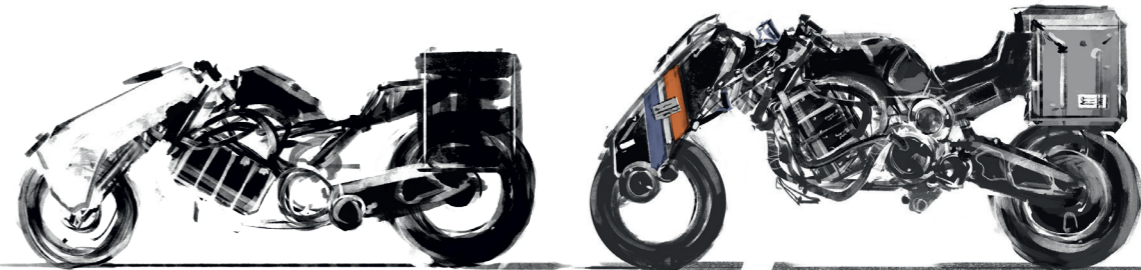
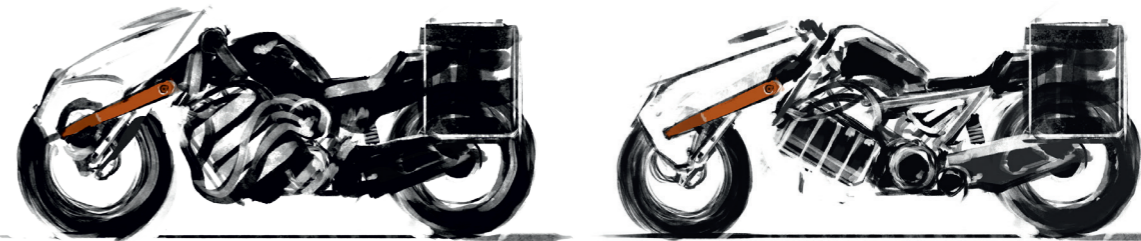

ABOVE / Early trike concepts.

BELOW / Vehicle pack concepts.

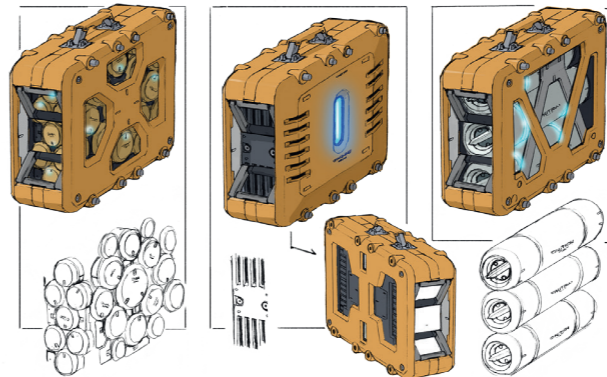

VEHICLES



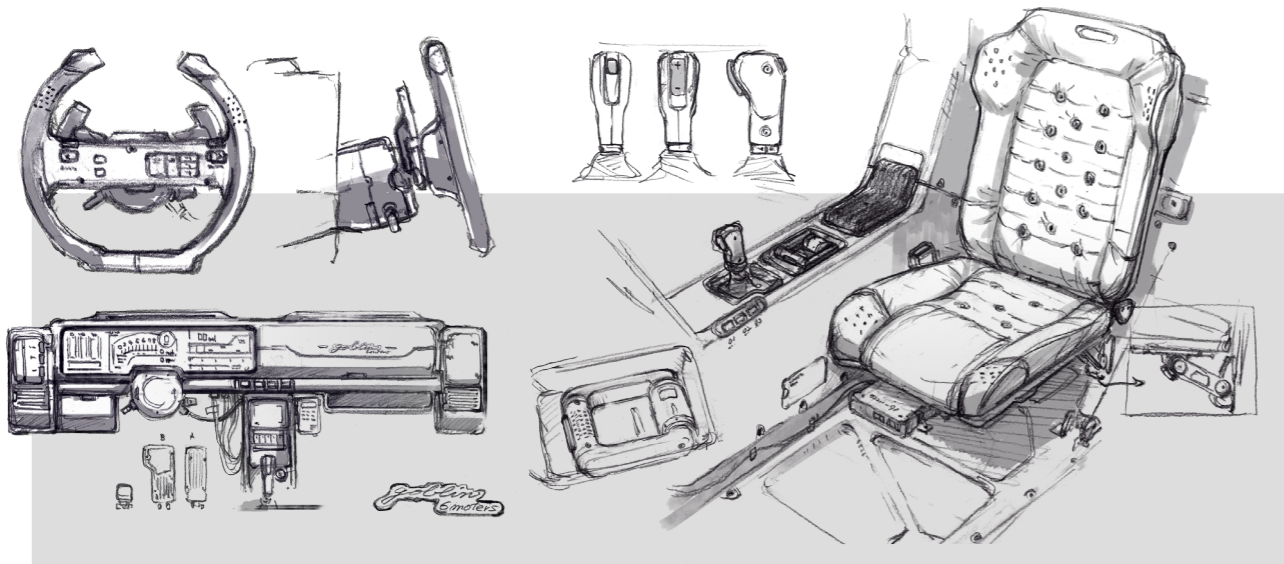

THIS PAGE / Details and close to final sketches of the truck-type vehicle.

PHI
PalmerHeavyIndustries

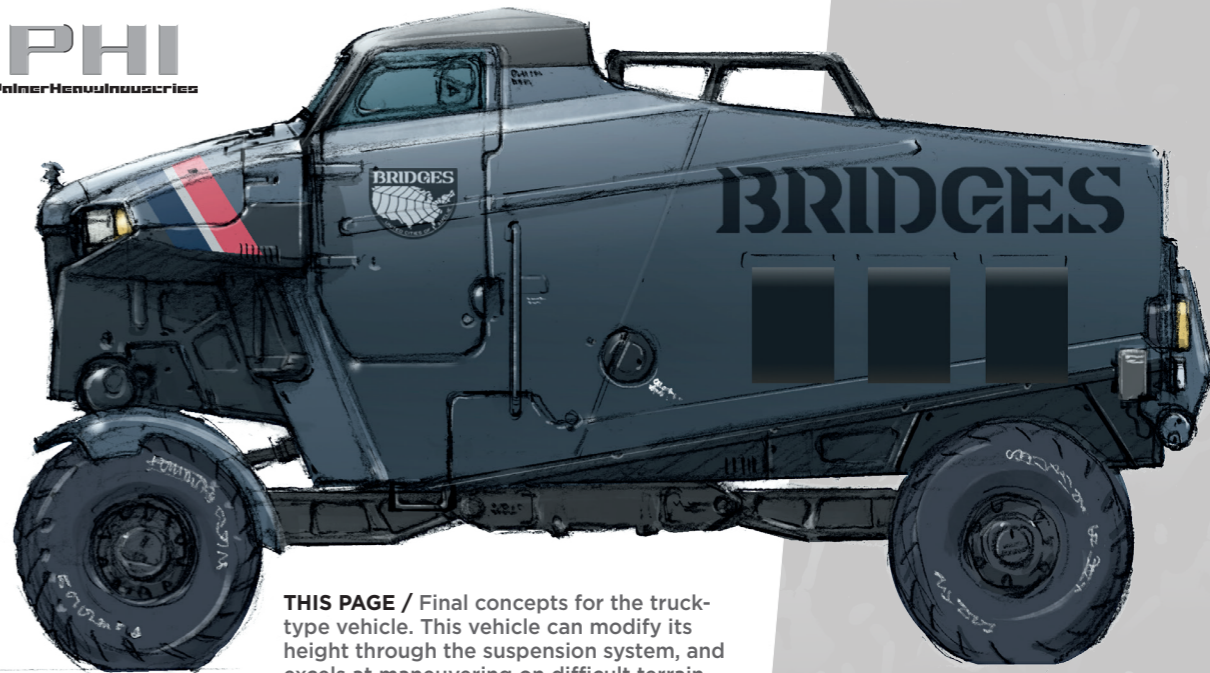

THIS PAGE / Final concepts for the truck-type vehicle. This vehicle can modify its height through the suspension system, and excels at maneuvering on difficult terrain. The uniqueness of the suspension allows this vehicle to get out of situations where it gets stuck, which is rather common in games.

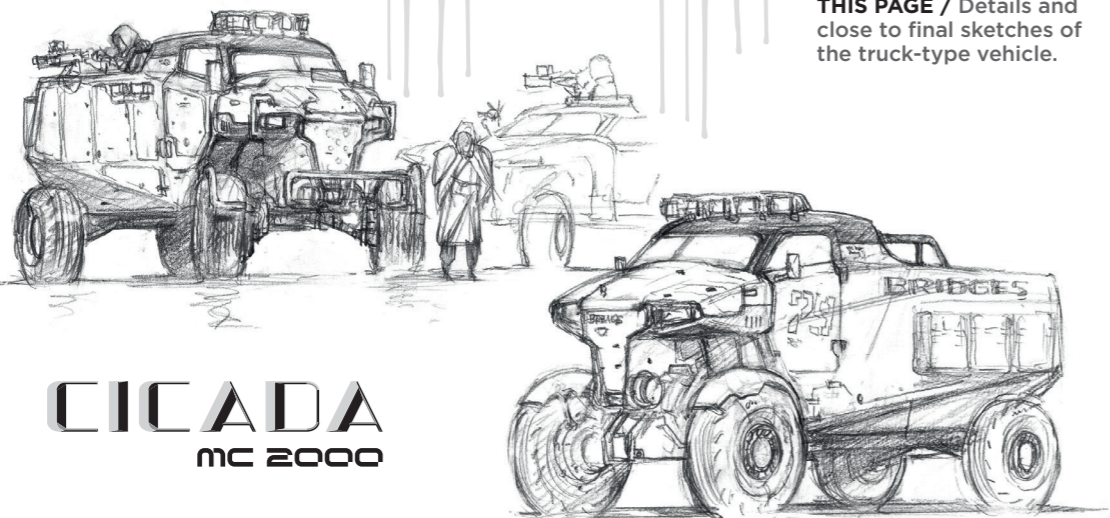

CICADA
MC 2000



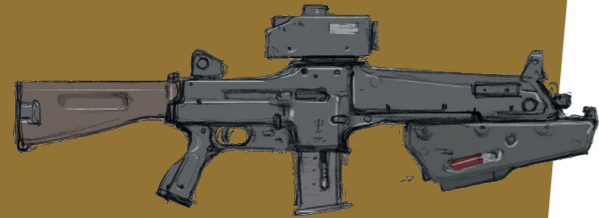

WEAPONS



ABOVE / CDT (Corpse Disposal Team) captain's knife.

LEFT / Early weapon concepts. The attached units for blood were already considered from early stages.



ABOVE / EX Grenades.

LEFT / Grenades used by Warriors.



BELOW / Unused gun, which Cliff carries on his chest.



BELOW / The gun that Die-Hardman carries.



BELOW / Unused weapon. A grenade to trigger holograms.

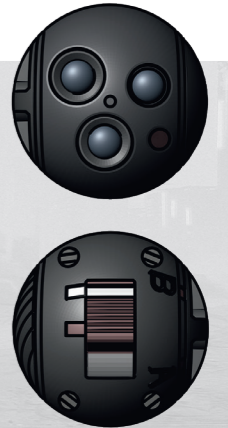

BELOW / Concepts for grenade launchers. The magazines work like those of revolvers, allowing the player to easily change the ammo in use.

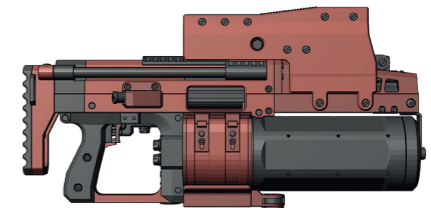
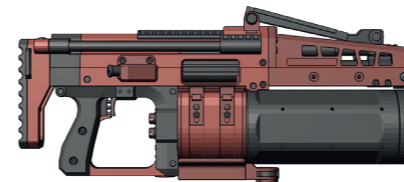
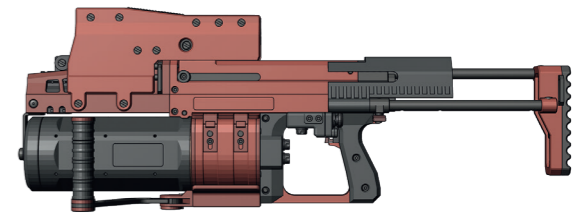

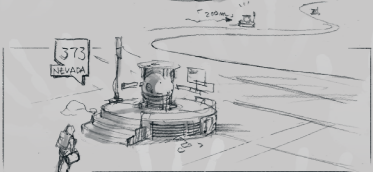
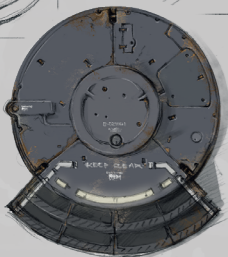
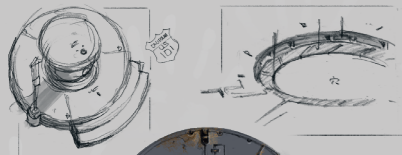

STRUCTURES & MECHS

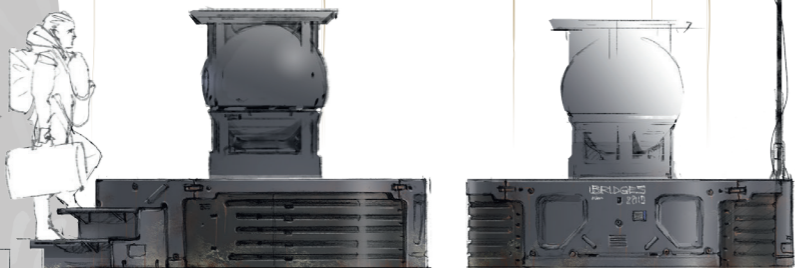

LEFT & ABOVE / Auto-Paver.

BELOW / Timefall shelter.

BELOW / Zip-line structure details.

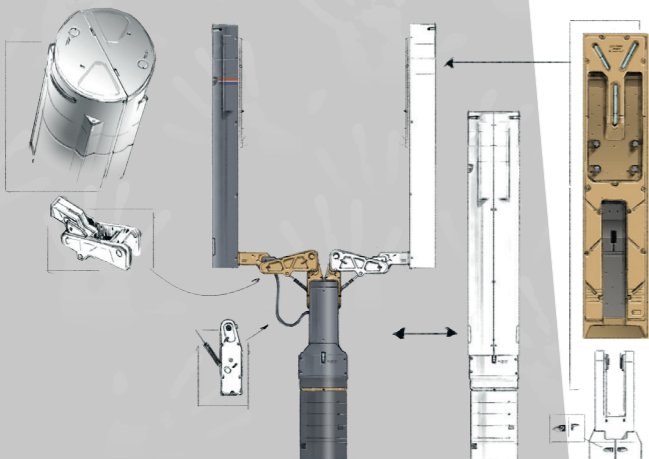

THIS PAGE / Auto-delivery bots. Bipedal mech for cargo delivery.

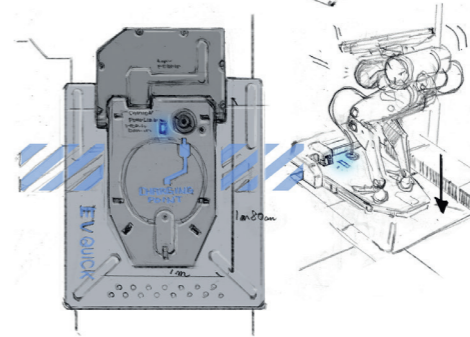
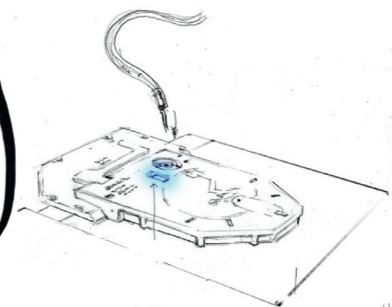
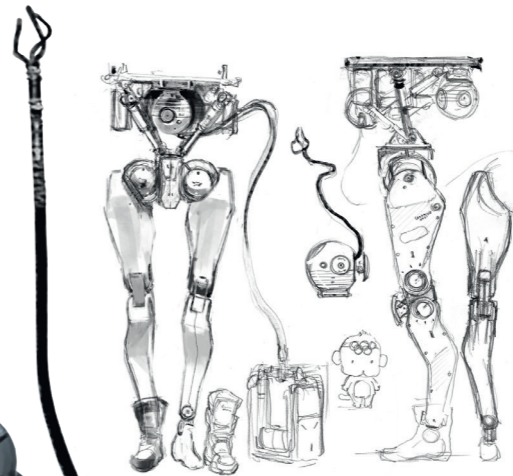



CAPITAL KNOT



ABOVE / Some of the major difficulties when creating concepts for the cities were to figure out the scale of how big they would be and to balance how desolate they should feel. While these cities are inhabited, the people in them don't venture outside and are isolated, confined to their respective indoors.

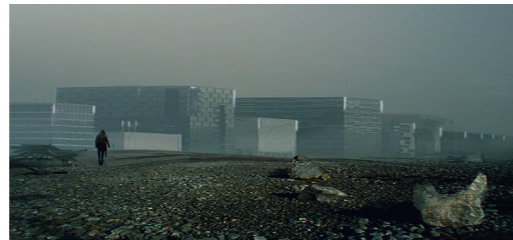

THIS PAGE / Early concepts for Bridges' headquarters, with ruins in the surrounding areas.



EDGE KNOT



OPPOSITE & ABOVE / Interiors of Edge Knot City.

BELOW / Edge Knot City from outside. Early concepts had a sunken BRIDGES I facility near its exterior.



EDGE KNOT

BRIDGES CENTER

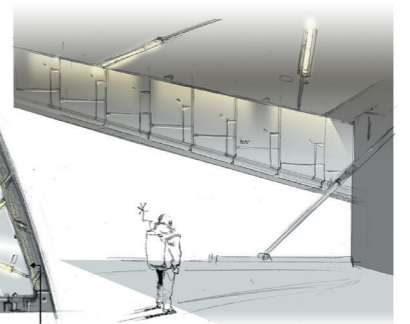
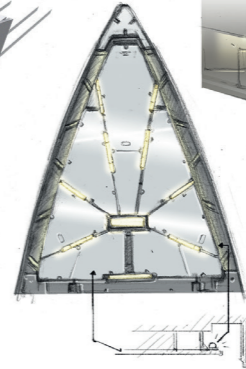
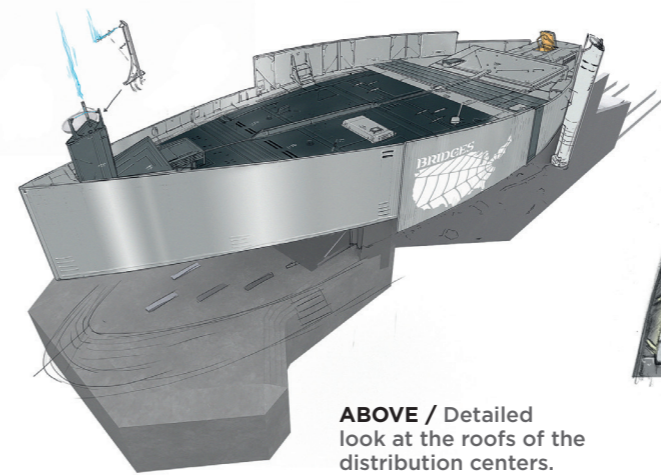
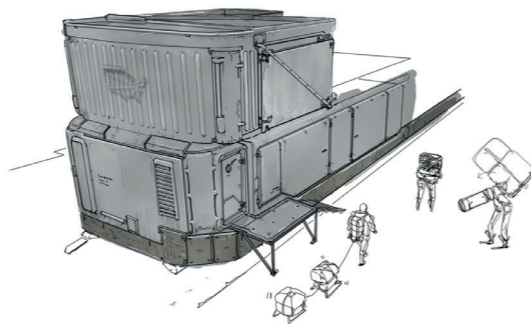
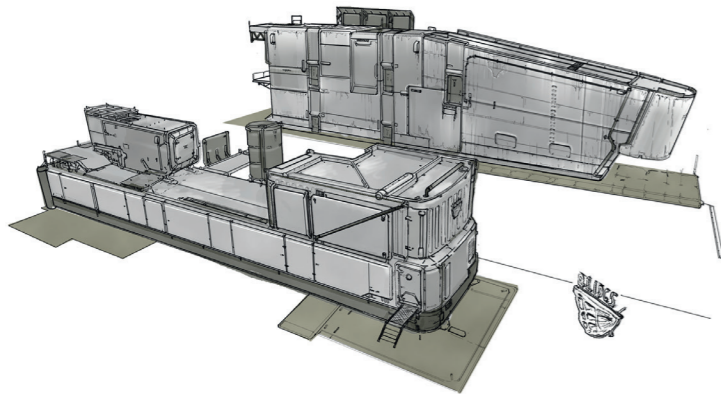
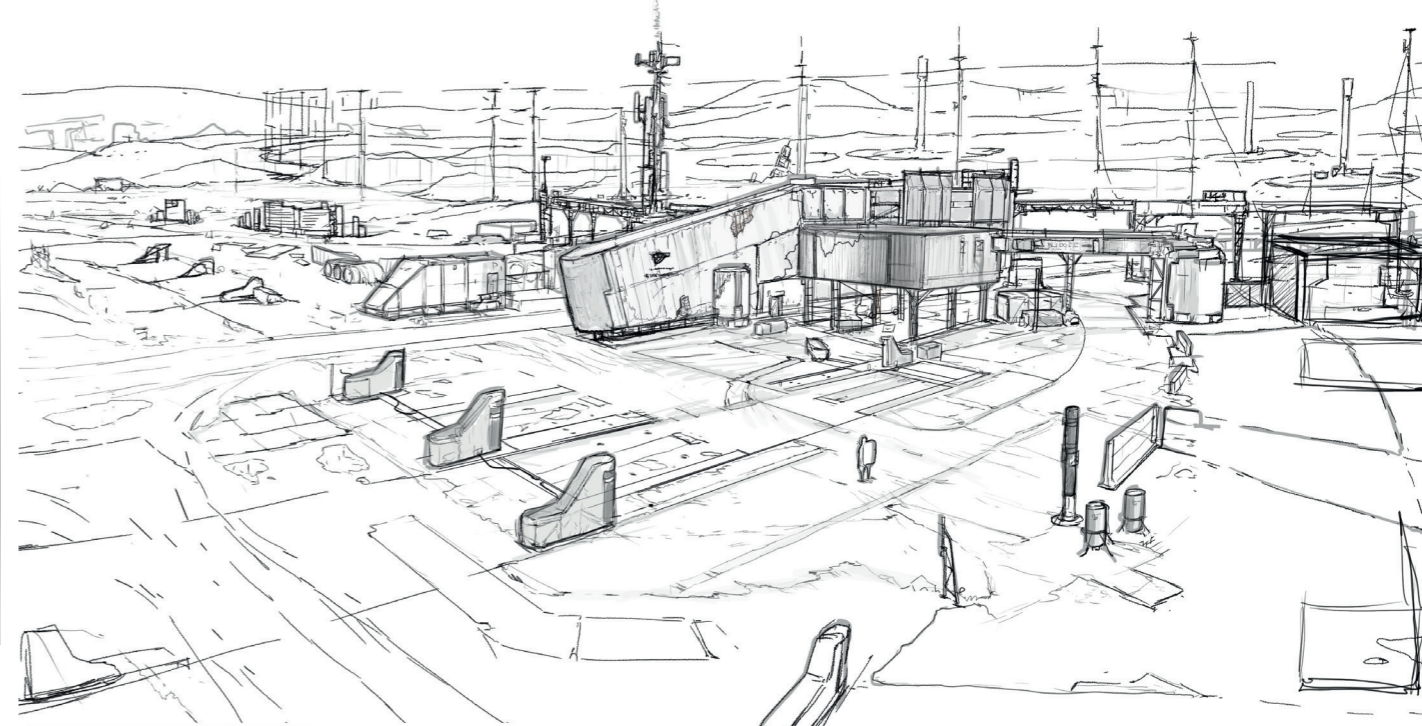
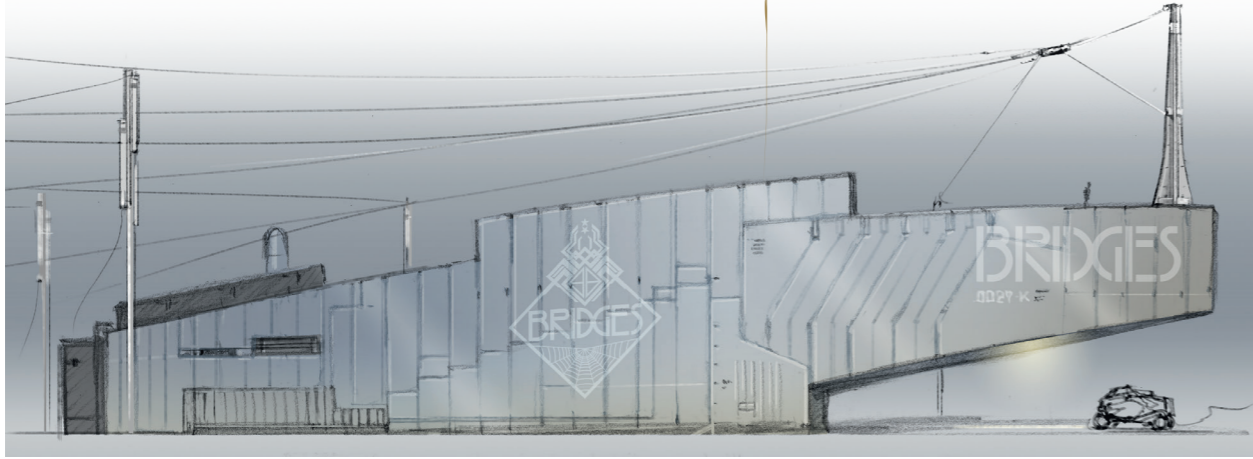

ABOVE / Detailed look at the roofs of the distribution centers.

LOCATIONS

BRIDGES CENTER

MAMA'S LAB



ABOVE / Early concept for Mama's lab, which features an early Bridges logo.

BELOW / Concepts for the interior of Mama's lab and the mobile for her baby.

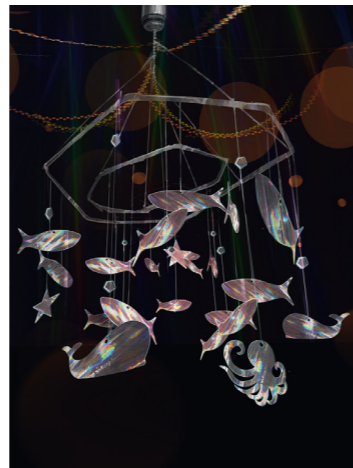

THIS PAGE / One of the concepts for Mama's lab had a crater created by a voidout next to the lab. Part of her lab was to have been destroyed by the voidout.

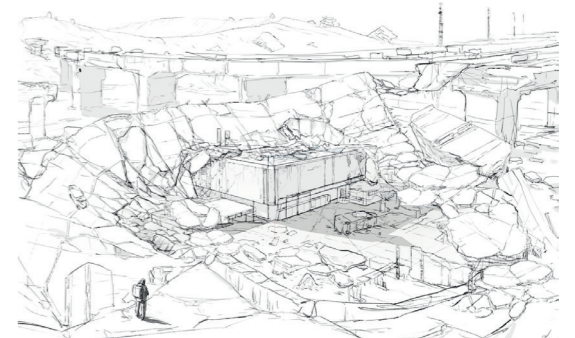
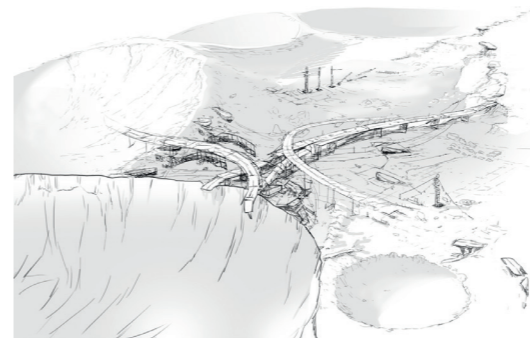

HEARTMAN'S LAB



ABOVE / Early concept for the entrance to Heartman's lab.

LEFT / Early concept for the heart-shaped lake.

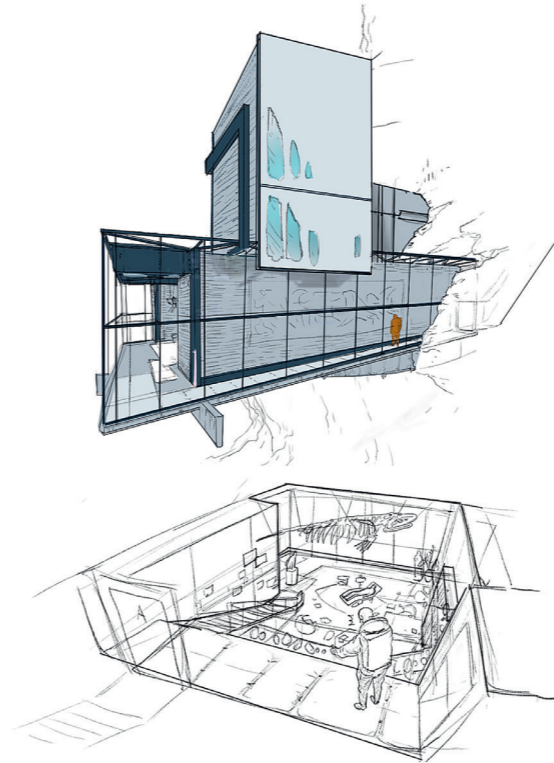

THIS PAGE / Concept variations for Heartman's lab.

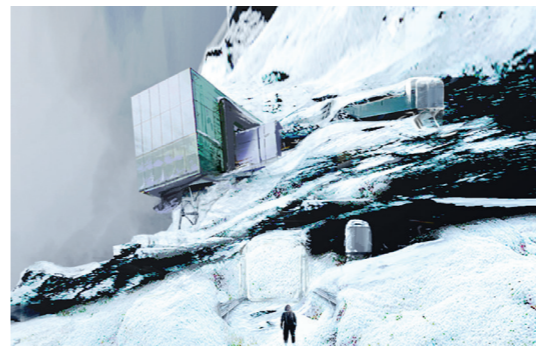

MULE CAMPS



MULE CAMPS

WAYSTATIONS



OPPOSITE / Near-final concept for waystations. **BELOW** / Early concept for waystations.



PRIVATE ROOM



ABOVE / Near-final concept for the private room.
LEFT / Early concept for the private room.

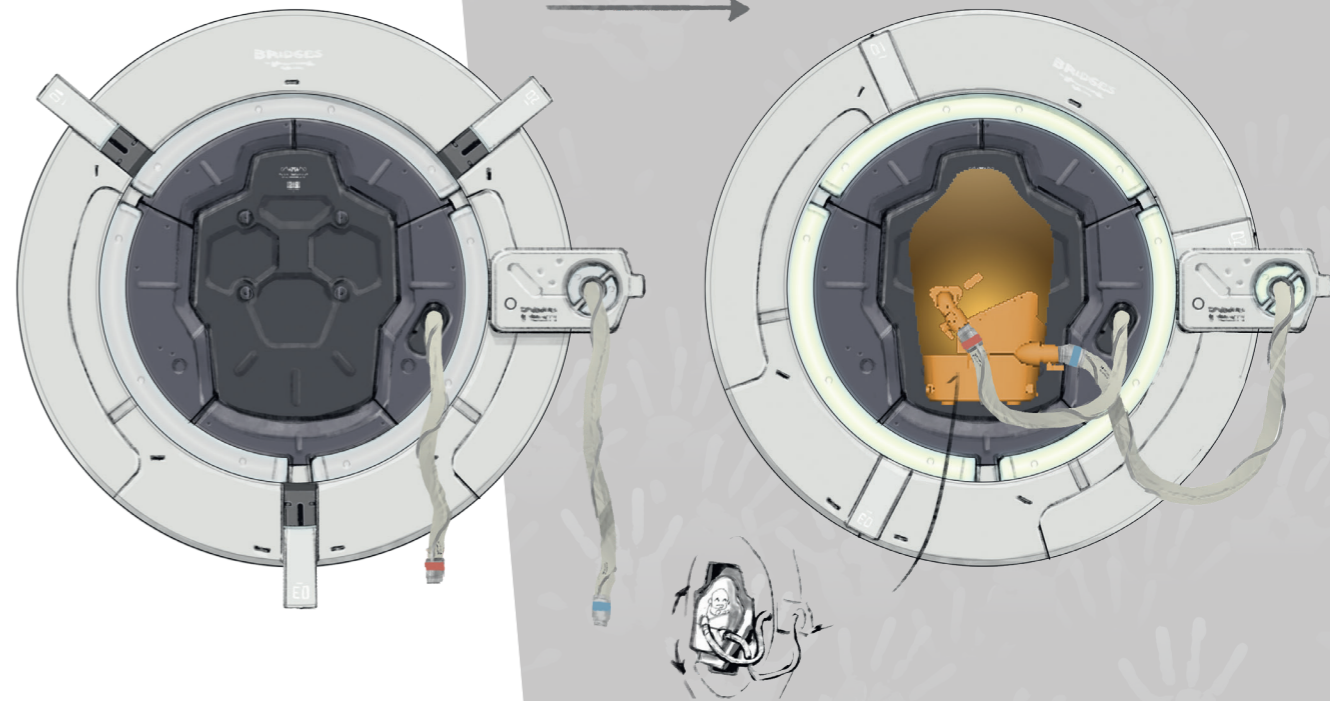

THIS SPREAD / Detailed look at the incubator in the private room.

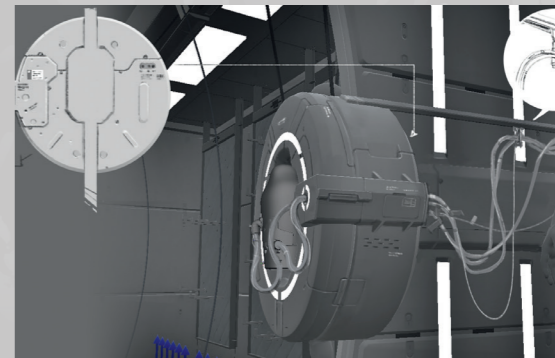

THE IMAGES IN THIS BOOK
ARE TAKEN FROM

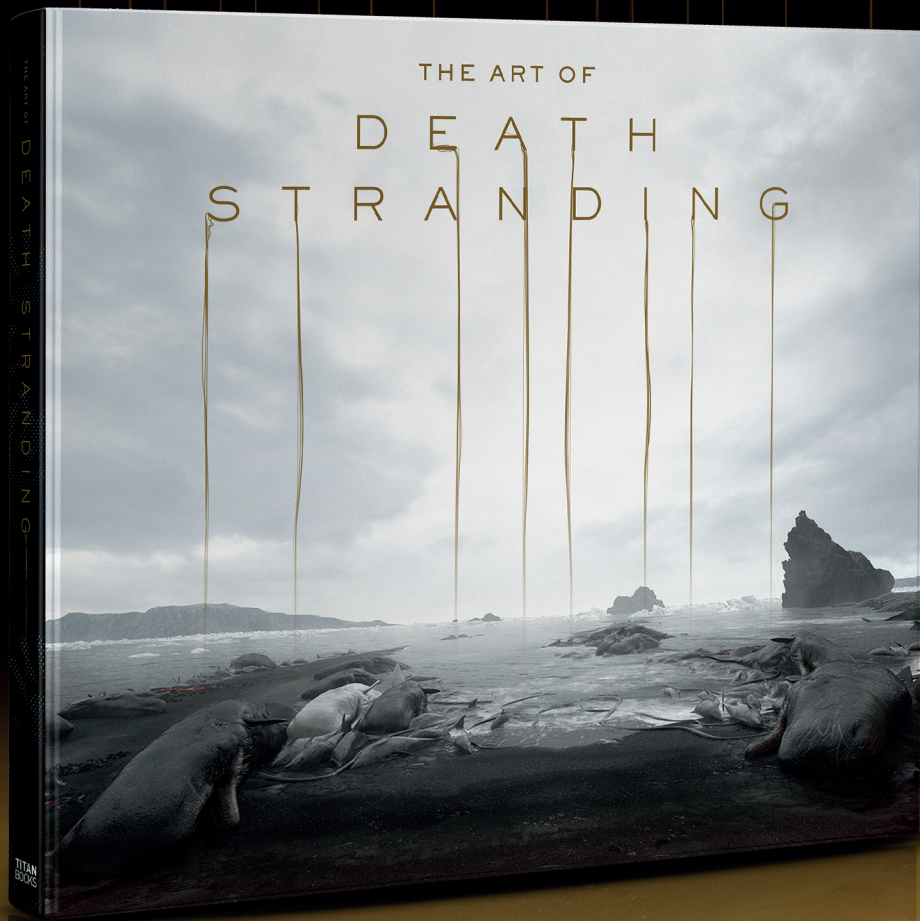

OUT NOW

TITANBOOKS.COM

TITAN
BOOKS

D E A T H
S T R A N D I N G



©2019 Sony Interactive Entertainment Inc.
DEATH STRANDING is a trademark of Sony Interactive
Entertainment LLC. Created and developed by
KOJIMA PRODUCTIONS. Manufactured under license from
Sony Interactive Entertainment LLC.