

7

湘北vs.翔陽

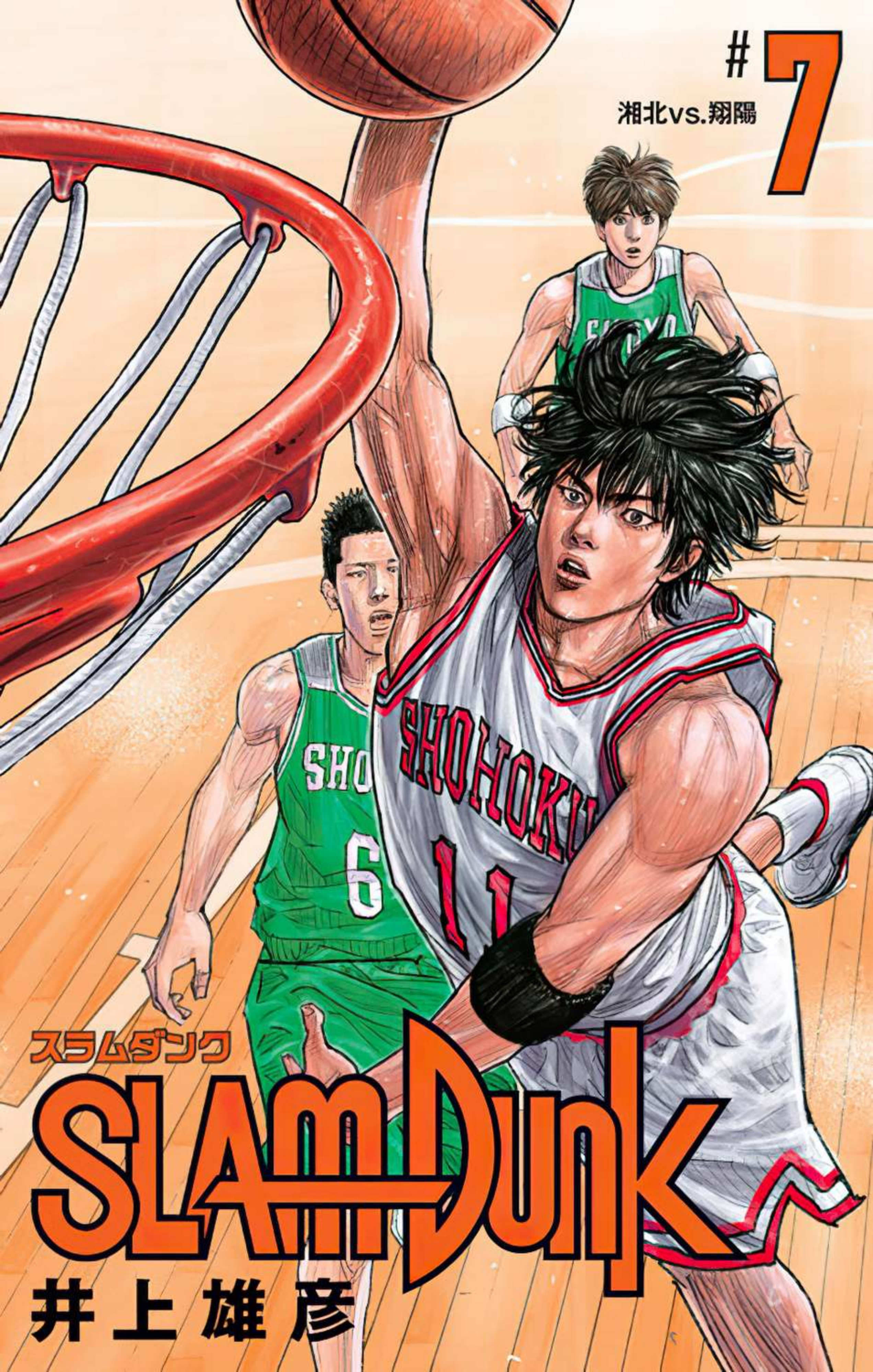

スラムダンク

SLAM DUNK

井上雄彦

SLAM  **DUNK**
by INOUE TAKEHIKO

スラムダンク

SLAM DUNK

新装再編版

CONTENIDO:

- 081. "OPONENTE FUERTE"
- 082. "TIP OFF"
- 083. "NO. 1 CENTRO"
- 084. "JUEGO INDIVIDUAL"
- 085. "FALTA DE COINCIDENCIA"
- 086. "JUICIO DE SHOYO"
- 087. "PRIMERA MITAD ENDING"
- 088. "SAKURAGI: REY DE REBOTES"
- 089. "SHOYO DE LA ESCUELA SECUNDARIA N° 4"
- 090. "A FUJIMA-LED SHOYO"
- 091. "60 SEGUNDOS"
- 092. "HACIA LA VICTORIA"
- 093. "DE MITSUI LIMIT BREAK"
- 094. "BASTARD DAMN"
- 095. "4 FALTAS"
- 096. "NOVATOS"
- 097. "INCLUSO SÓLO UNA CASUALIDAD"
- 098. "CELEBRITY DE HOY"

[HTTPS://MAR9CEלו3.BLOGSPOT.COM/](https://mar9ceלו3.blogspot.com/)

**SLAM
DUNK**

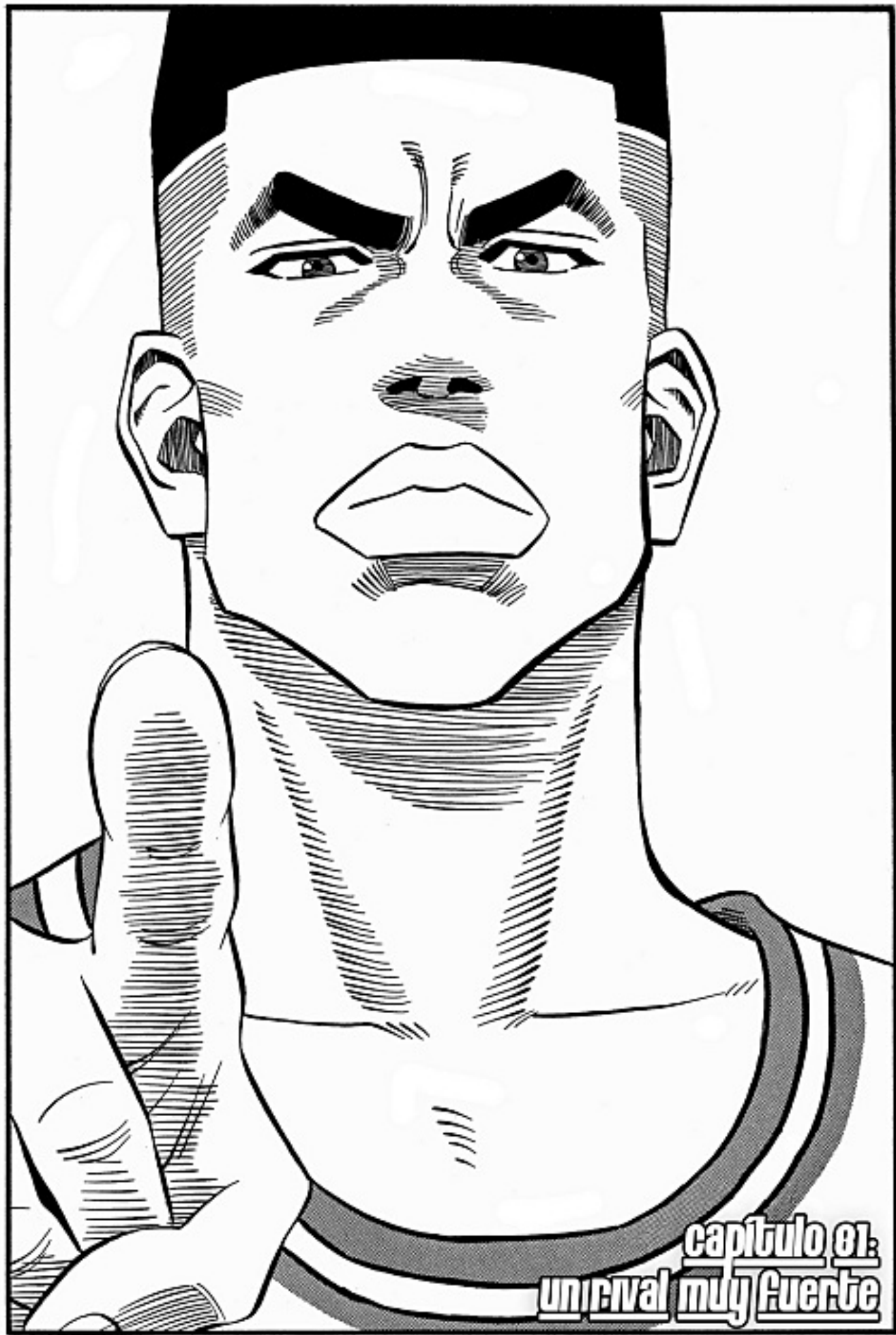

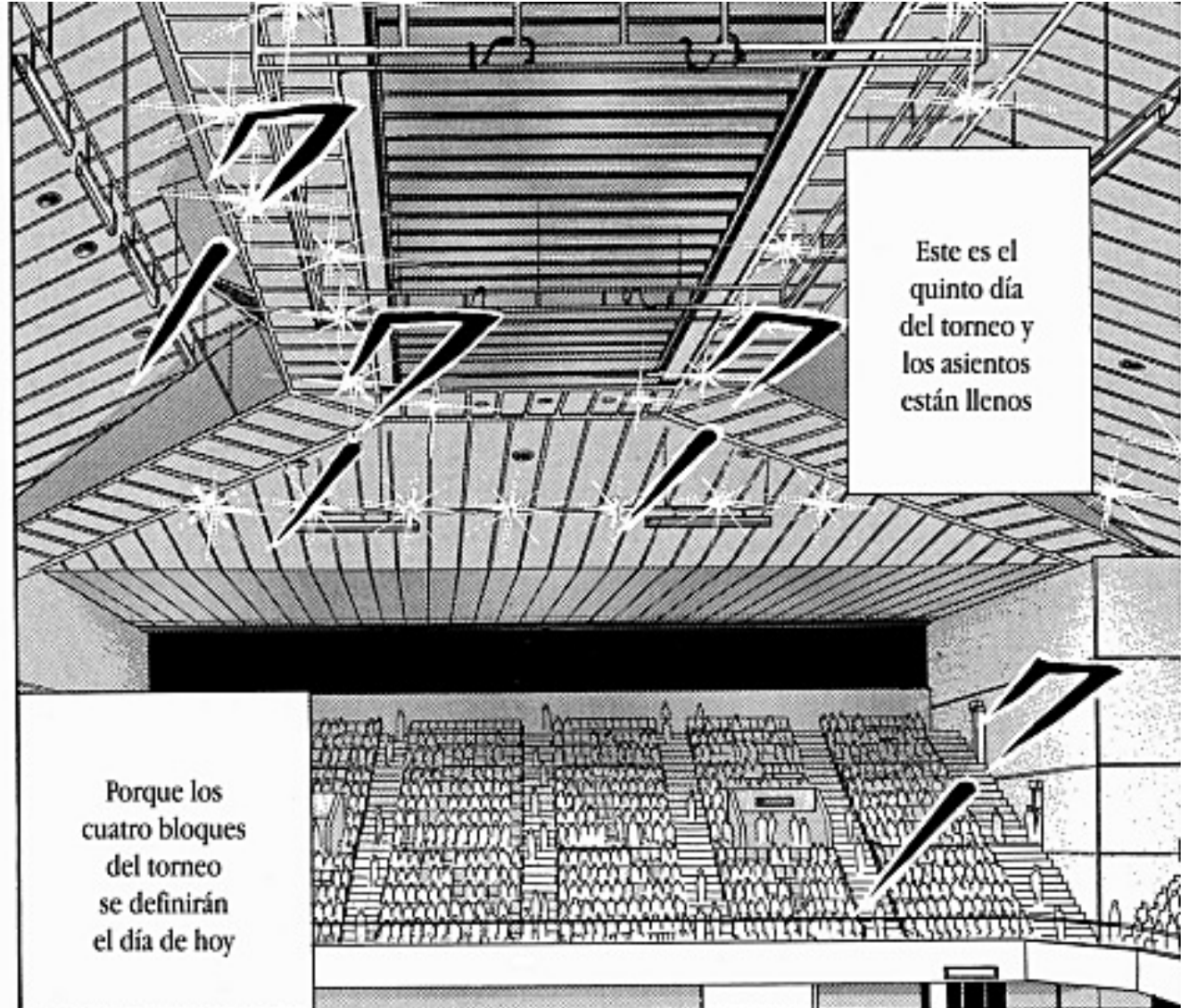

Este es el quinto día del torneo y los asientos están llenos

Porque los cuatro bloques del torneo se definirán el día de hoy

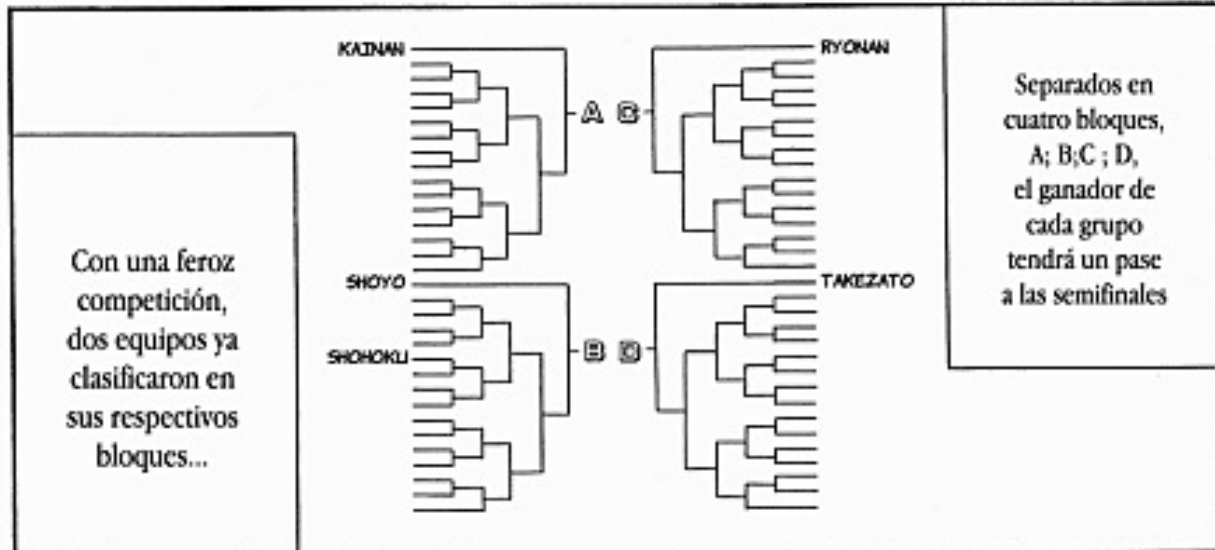

Con una feroz competición, dos equipos ya clasificaron en sus respectivos bloques...

Separados en cuatro bloques, A; B; C; D, el ganador de cada grupo tendrá un pase a las semifinales

Y líder de
su bloque,
el instituto
Kainan

KAINAN

Uno de
ellos es el
campeón del
año pasado

RYUGASAKI







¡ESTE PARTIDO ES EL DECISIVO!



INCLUSO AKAGI NO PUDO DORMIR POR LOS NERVIOS POR EL PARTIDO... YO NO PUDE CONCILIAR EL SUEÑO HASTA LAS 4 DE LA MAÑANA...

¡CÁLLATE!

¡TIENES OJERAS!



TIENEN QUE DAR LO MEJOR DE LISTEDS

SHOYO NO ES COMO LOS DEMÁS EQUIPOS QUE ENFRENTAMOS HASTA AHORA...



MITSUI, ESTAMOS A PUNTO DE EMPEZAR... ¿DÓNDE VAS?

¿QUÉ?

NO SÉ POR QUÉ SE PONEN TAN NERVIOSOS, SÓLO ES SHOYO...

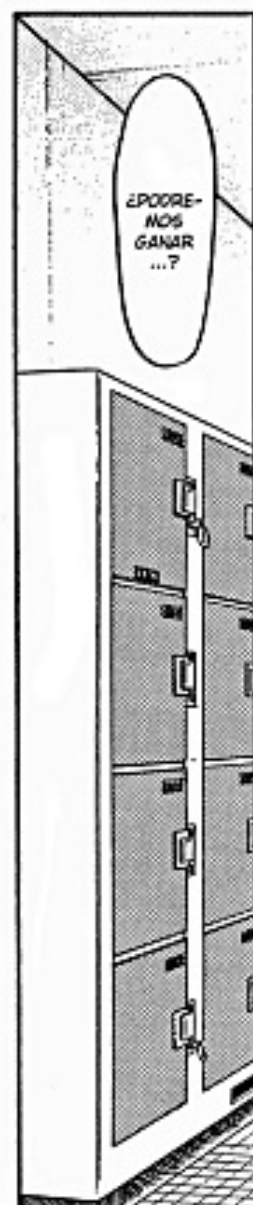

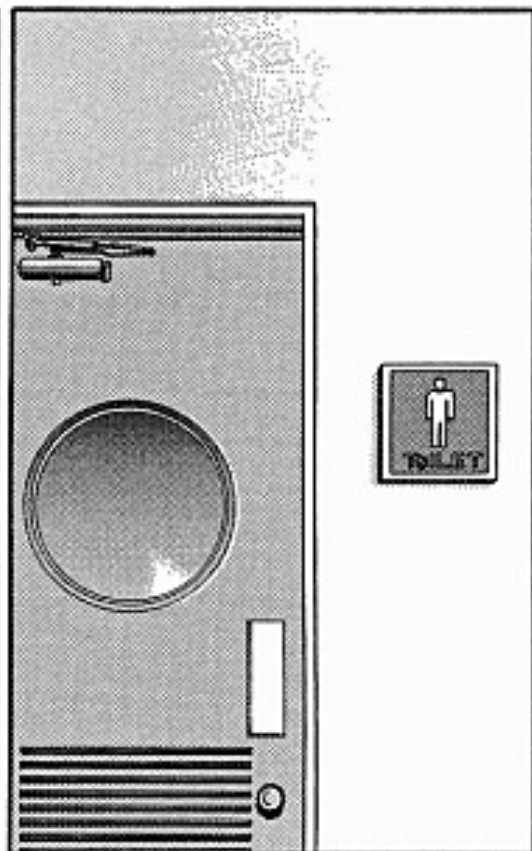

Nota: "gaya" es el ruido de los tenis de basketball en el suelo







*¡¿CINCO
PUNTOS?!*



*¡¿QUIÉN
MIERDA
ERES?!*

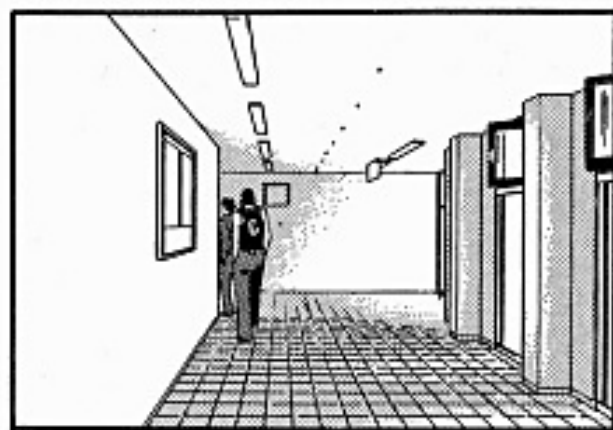





¡OH!!!
¡AHÍ
ESTÁN!

¡ES EL
EQUIPO DE
SHOHOKU!



¡NO TIENEN
CHANCES!

¡NO SE
VEN TAN
BUENOS!

BLAH
BLAH

¡NO ESTÁN
AL NIVEL
DE SHOYO!



¡¿EH?!

ESAS VECES...

¡HANAMICHI,
AÚN TE VES
TAN NERVIOSO
COMO DE
COSTUMBRE!



HAY
UNA GRAN
CANTIDAD
DE ESPEC-
TADORES

HOY ES
EL DÍA EN
DÓNDE VOY
A PROBAR
QUE SOY
UN GENIO

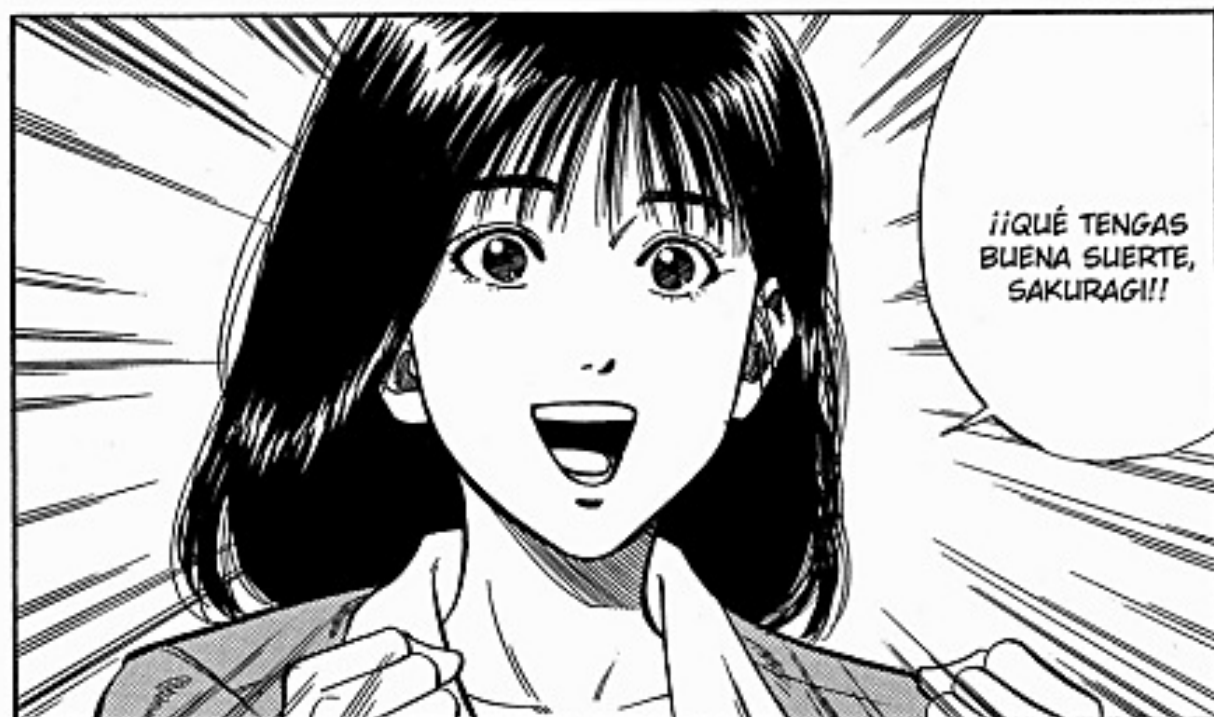



¡HARUKO!



¡S-SÍ!

¿QUÉ
DIABLOS
HACES?!
¡VEN
RÁPIDO!



MI META EL
DÍA DE HOY
ES NO SER
EXPULSADO

¡Y ANOTAR
MÁS PUNTOS
QUE RUKAWA
...!



¡BIEN,
ESTE ES
MI DÍA!

¡DEBO
HACER
TODO
BIEN!

SHOTO!!



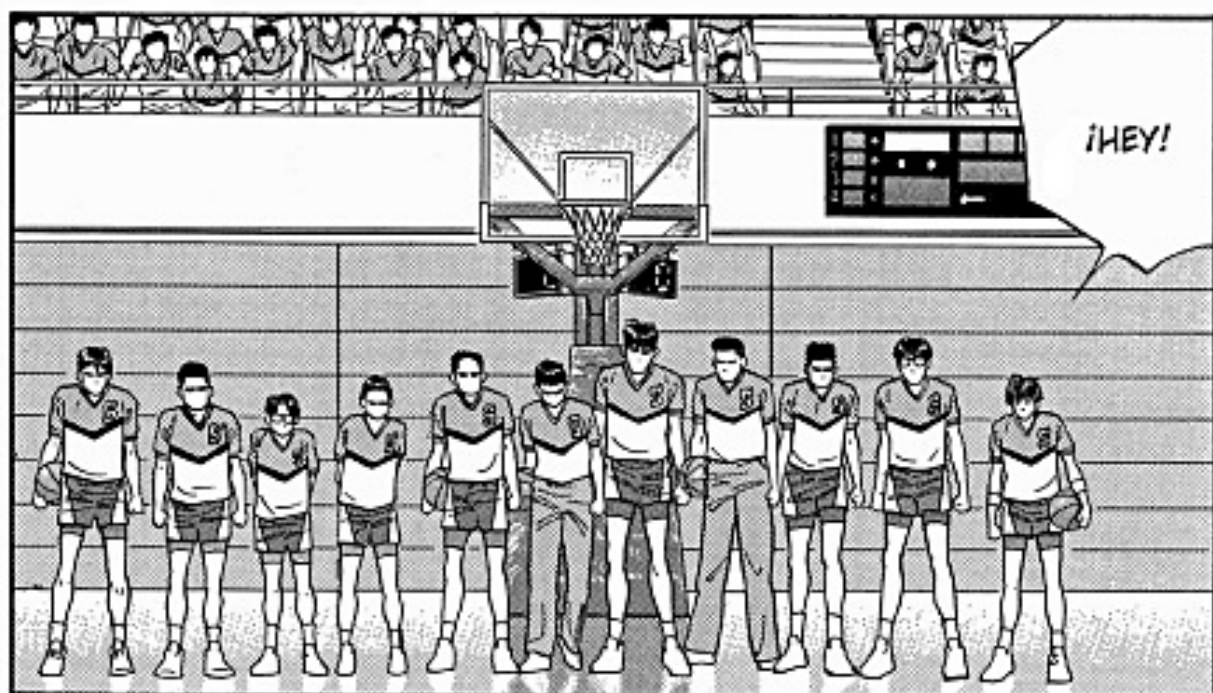

¡LOS SUB-
CAMPEONES
DEL TORNEO
PASADO!

¡HOYO!

¡TODOS SON
MUY ALTOS!

¡ESTE AÑO
TAL VEZ
PUEDAN
VENCER A
KAINAN!



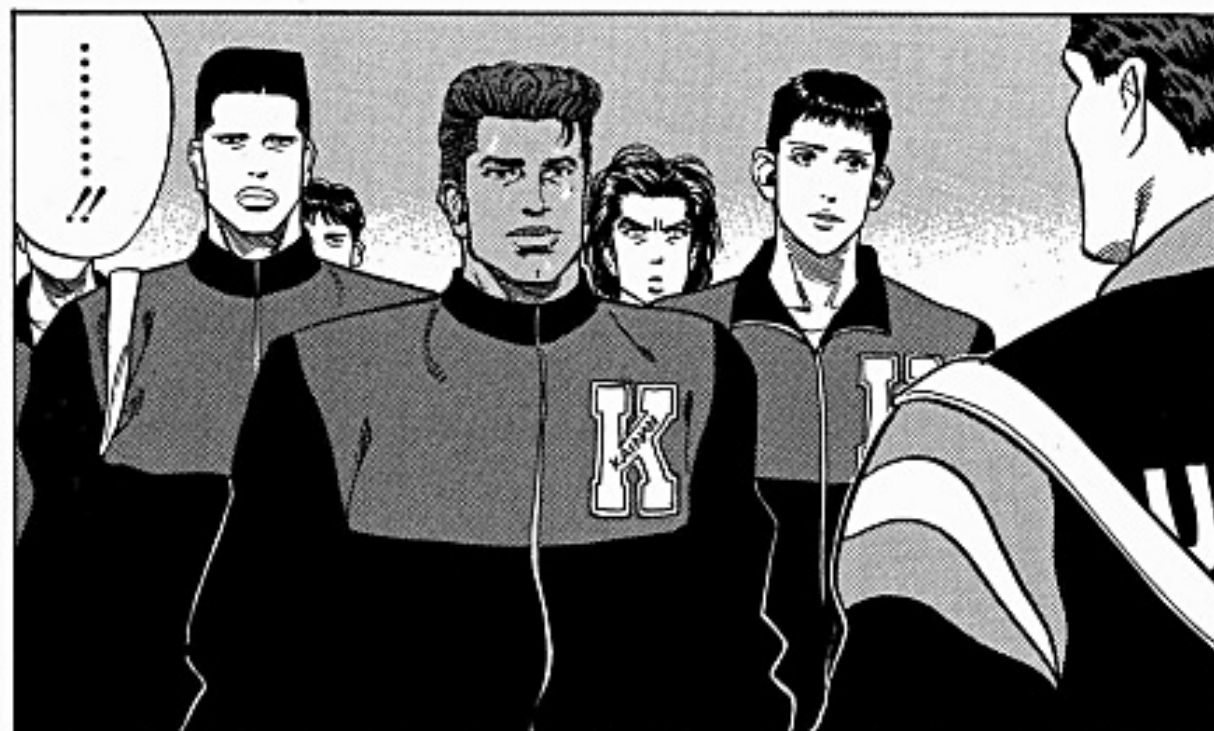



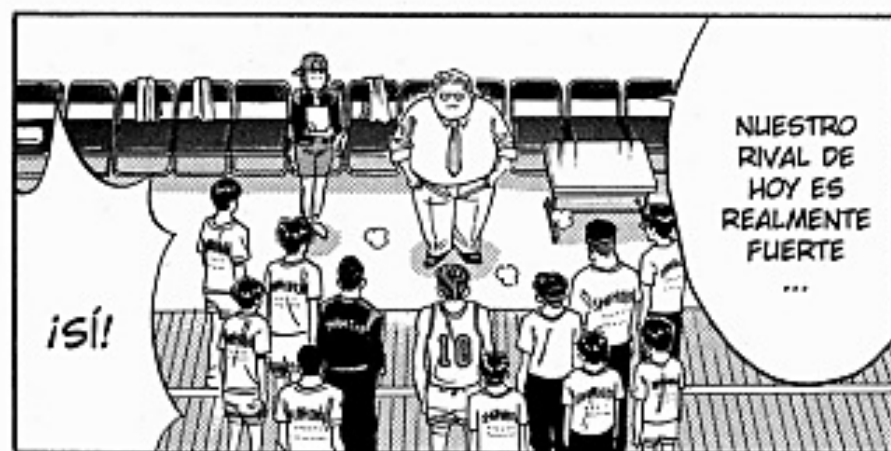

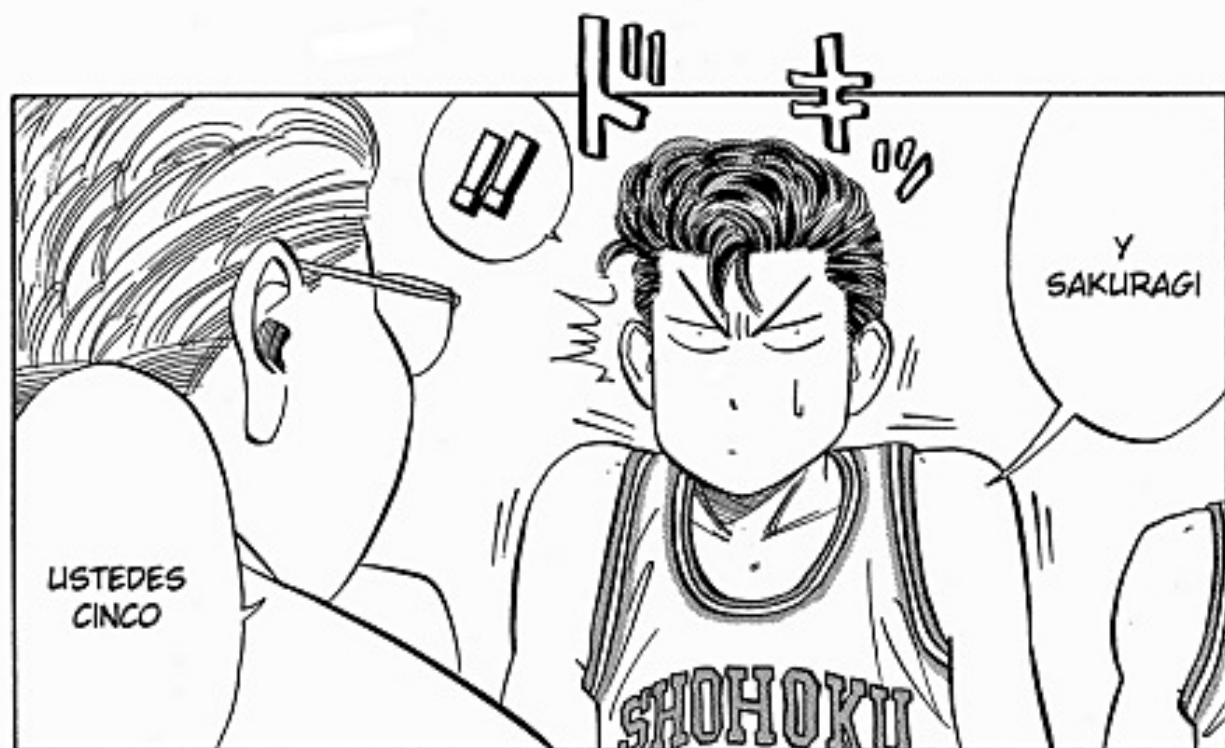

Genius-sub's

visítanos en:

<http://geniussubs.co.cc>

Corrección y
montaje
Manaka

Traducción:
Kageroyami
Red-Hellin;
Manaka

Limpieza:
ariel
jope
manaka
wurtang

**SLAM
DUNK**



¡SÍ,
VIEJO!

SAKURAGI



BIEN, ESO
ES TODO,
EL JUEGO
ESTÁ A
PUNTO DE
EMPEZAR

AKAGI,
RUKAWA,
SAKURAGI,
USTEDES
TRES DEBEN
ENCARGAR-
SE DE LOS
QUE TIENEN
MÁS ALTURA
DE SHOYO



TIENES QUE
CONTROLAR
TODOS LOS
REBOTES



TU DEBER
EN ESTE
PARTIDO ES
MANTENERTE
DEBAJO DEL
ARO...



¡DEN SU
MEJOR
ESFUER-
ZO!

HISASHI MITSUI
⑭ ESCOLTA-TERCER AÑO
184cm 70kg

RYOTA MIYAGI
⑦ BASE-SEGUNDO AÑO
168cm 59kg



¡ADE-
LAN-
TEE!



KAEDE RUKAWA
⑪ ALERO-PRIMER AÑO
187cm 75kg



¡¡SÍ!!

HANAMICHI
SAKURAGI
⑩ ALA-PIVOT-PRIMER AÑO
188cm 83kg



¡VAMOS!

TAKENORI AKAGI
④ CENTRO-TERCER AÑO
197cm 90kg

capítulo 02: tip-off







ASÍ QUE
SÓLO SALGAN
A JUGAR Y
DEN SU MEJOR
ESFUERZO

KENJI FUJIMA

④ *BASE Y ENTRENADOR (TERCER AÑO)*

178cm 66kg





AUNQUE ESTO
NO IMPORTA,
LOS CUMPLIRÉ
TODOS!

¡RAVE,
HOY TENGO
MUCHOS
OBJETIVOS!

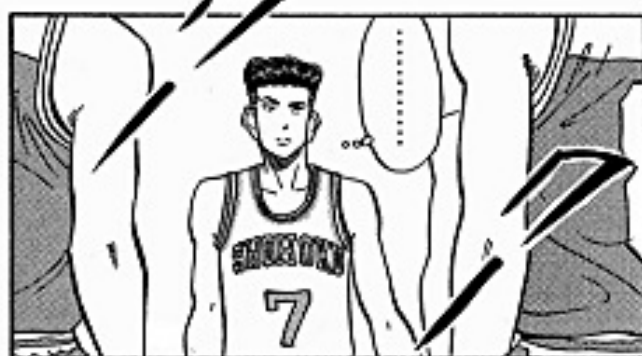

TODOS SON
MUY ALTOS..



¡VOY A
ANOTAR
MÁS
PUNTOS
QUE
RUKAWA!

¡NO VOY
A SER
EXPUL-
SADO!

¡VOY A
DOMINAR
TODOS LOS
REBOTES
HOY!



¡ITO!

TAKU ITO
⑨ BASE-SEGUNDO AÑO
180cm 71kg



¡ITO!

¡ITO!

¡ITO!





TOORU HANAGATA
⑤ CENTRO- TERCER AÑO
197cm 83kg





¡EL PARTIDO
ENTRE EL
INSTITUTO
SHOHOKU Y
EL INSTITUTO
SHOYO DA
COMIENZO!

¡A JUGAR!



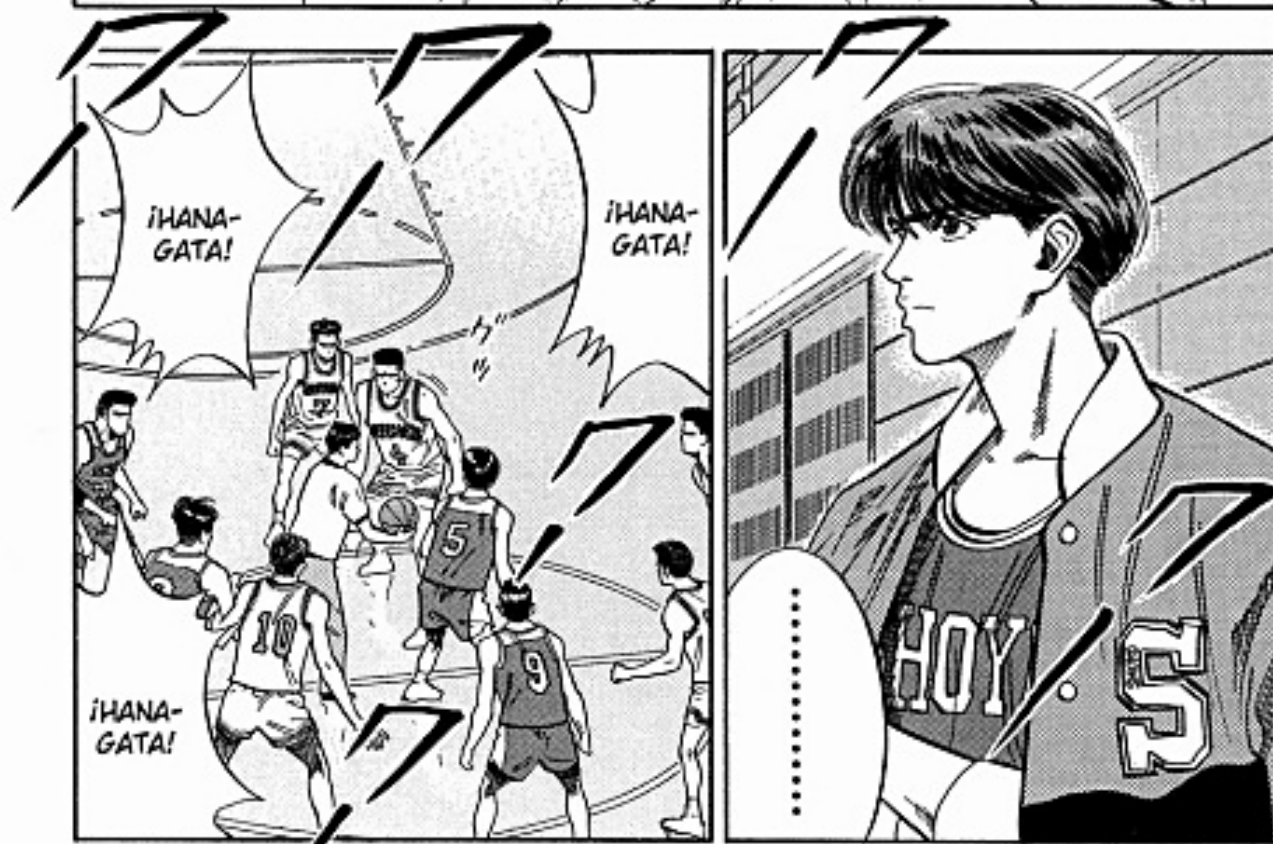



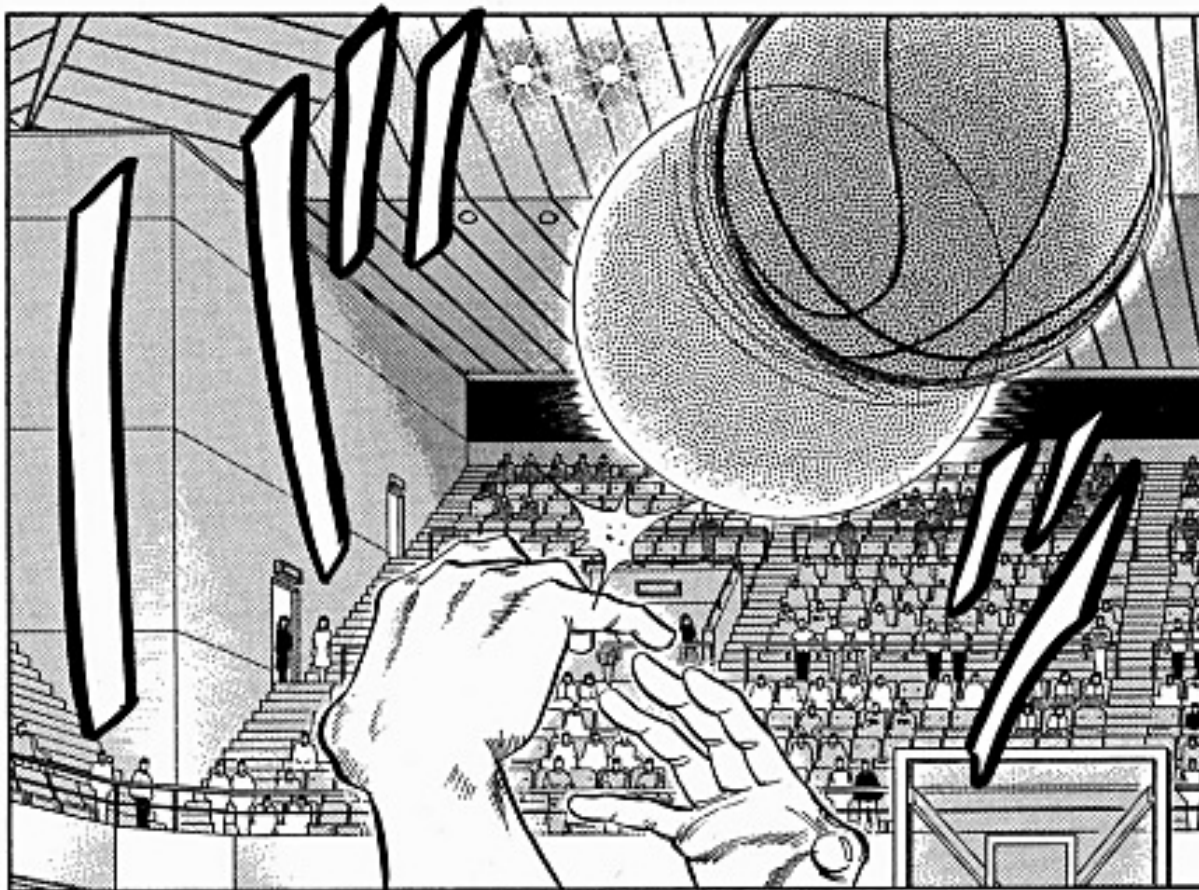



Nota de traducción: en el salto entre 2, el balón debe ser tocado después de alcanzar su punto más alto, no antes

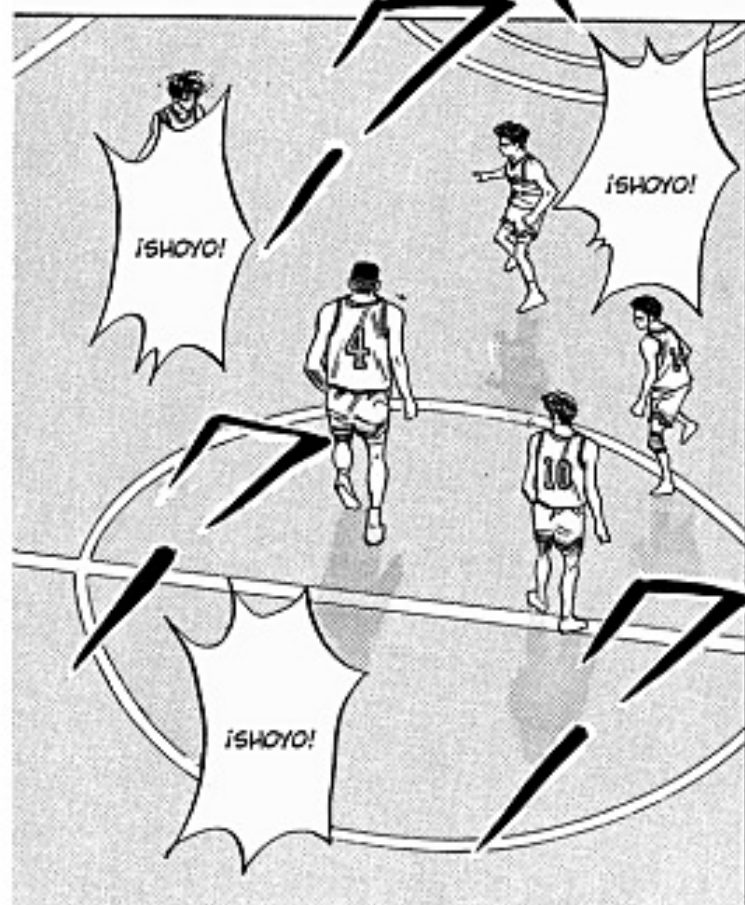

GENIUS-SUBS

**CORRECCION Y
MONTAJE
MANAKA**

LIMPIEZA:

ARIEL

JOPE

MANAKA

WURTANG

TRADUCCION:

KAGEROYAMI

RED-HELLING

MANAKA

visítanos en:

<http://geniussubs.co.cc>

**SLAM
DUNK**

capítulo 83



el centro número 1

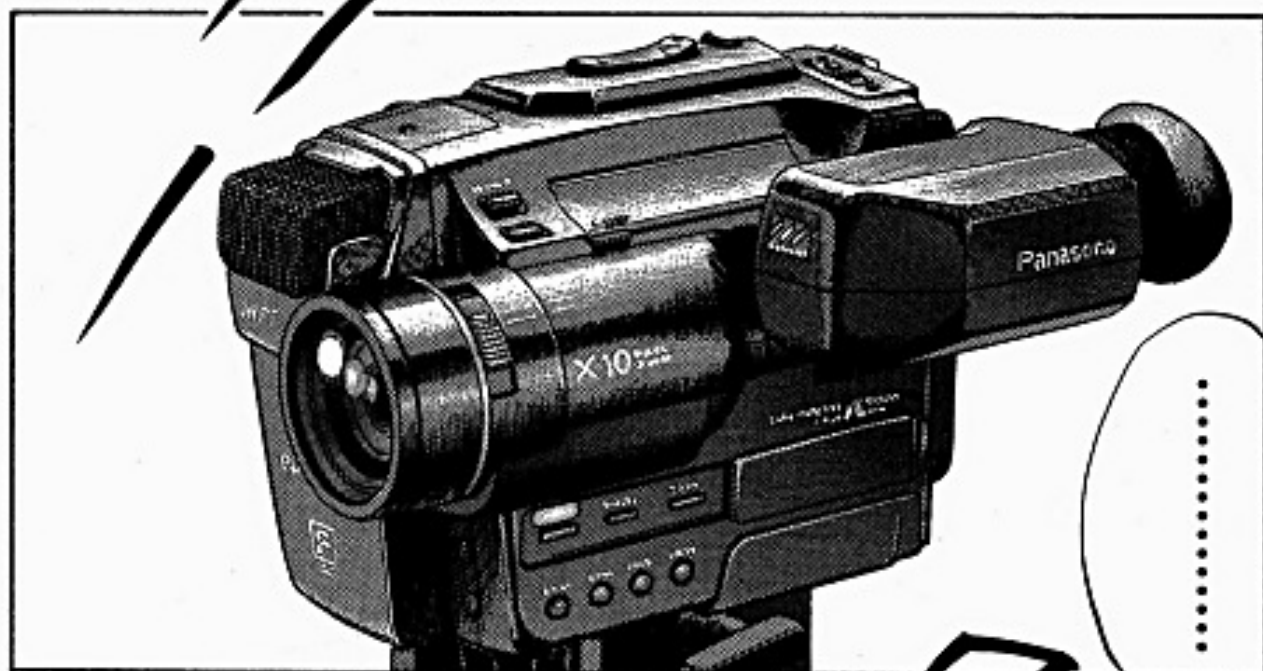

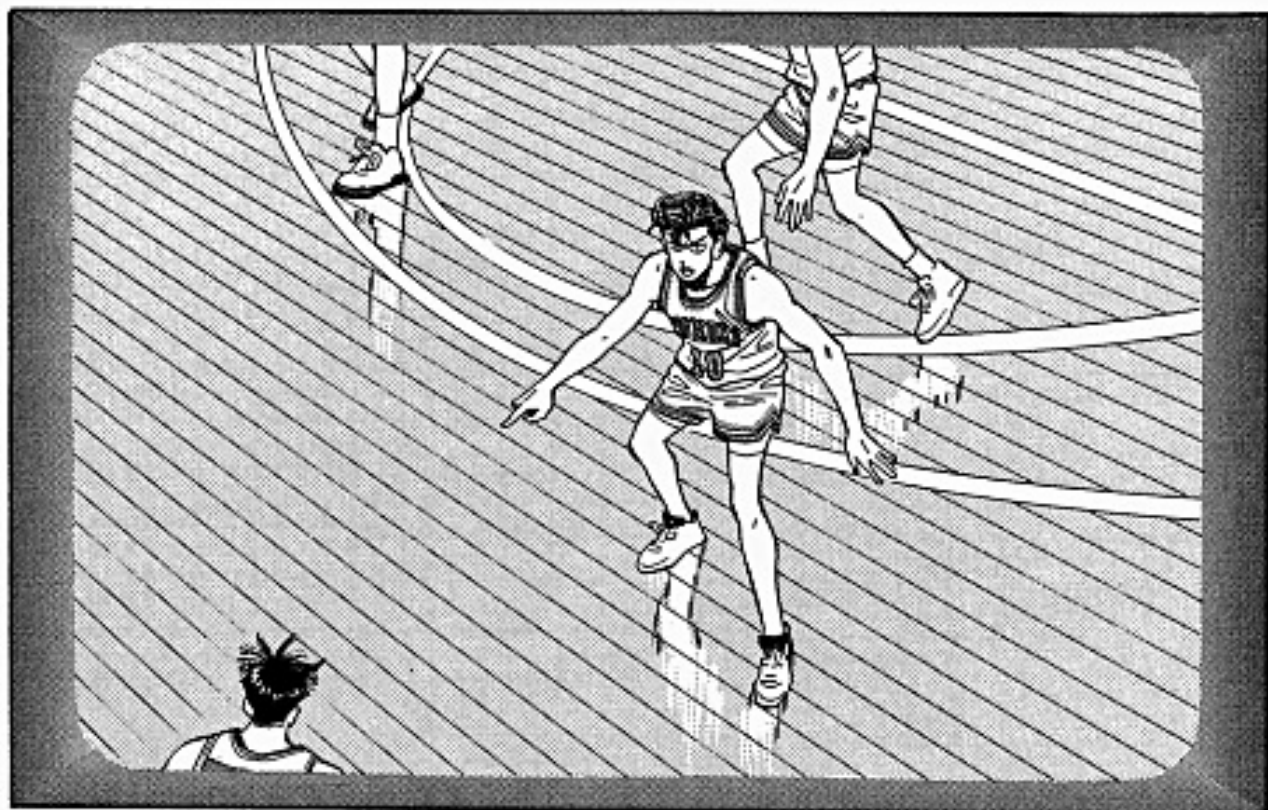







¡SI LOGRO DETENER
A HANAGATA AHORA,
PODREMOS PONER
ESTE PARTIDO A
NUESTRO FAVOR!





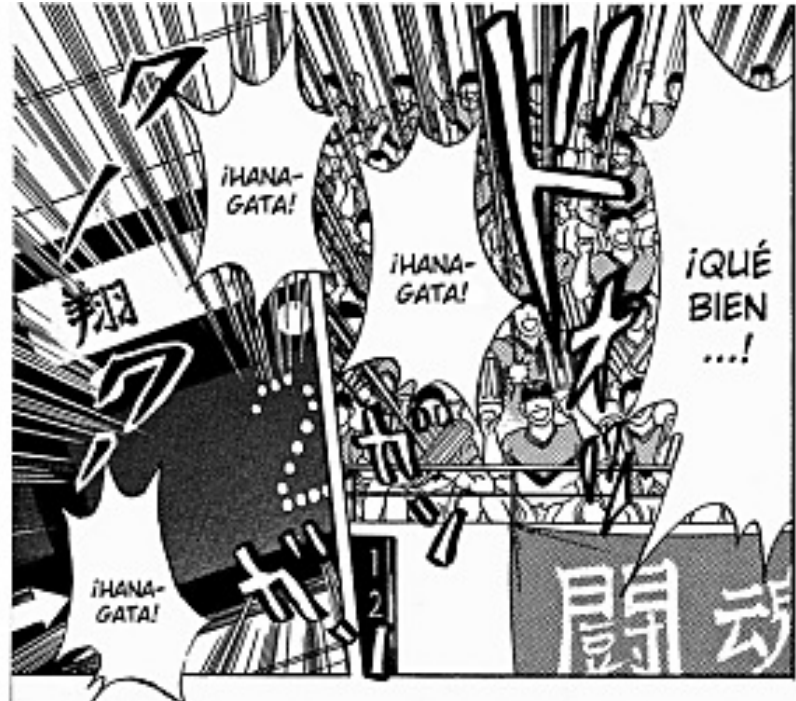

Las lecciones de Basketball del Dr.T

<< - FADE AWAY- Salto hacia atrás - >>

Al realizar el salto para tirar, se lo dirige hacia atrás, de esta manera, se puede realizar un tiro más libre de marcas y tapones, pero si se va para atrás demasiado, se puede perder el equilibrio e incluso caer...



Cuatro ojos



¡PARA YA, SAKURAGI!

Cuatro ojos



アッ
アッ
アッ

¿EH ...?

¡MALDITO CUATRO OJOS!



NO TE PASES DE LISTO, YO TE VOY A DERROTAR ...



¡ESPERA!

¿CÓMO TE ATREVES A IGNORAR A UN GENIO, CUATRO OJOS?!



.....
はルッ

!!!



¿EH?

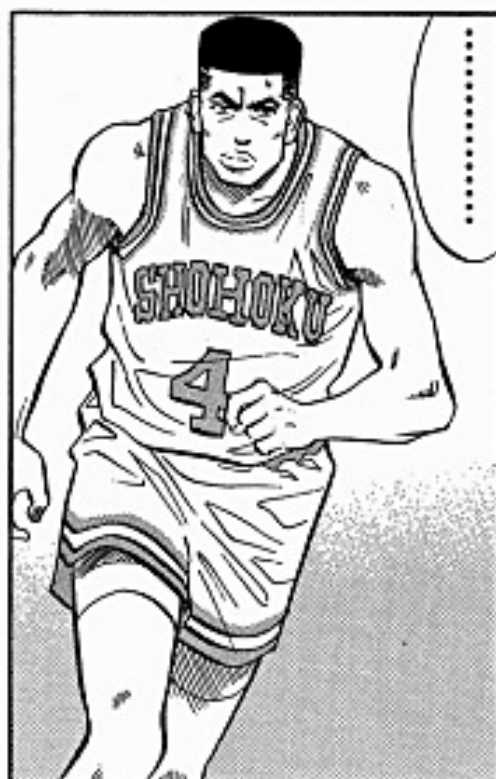

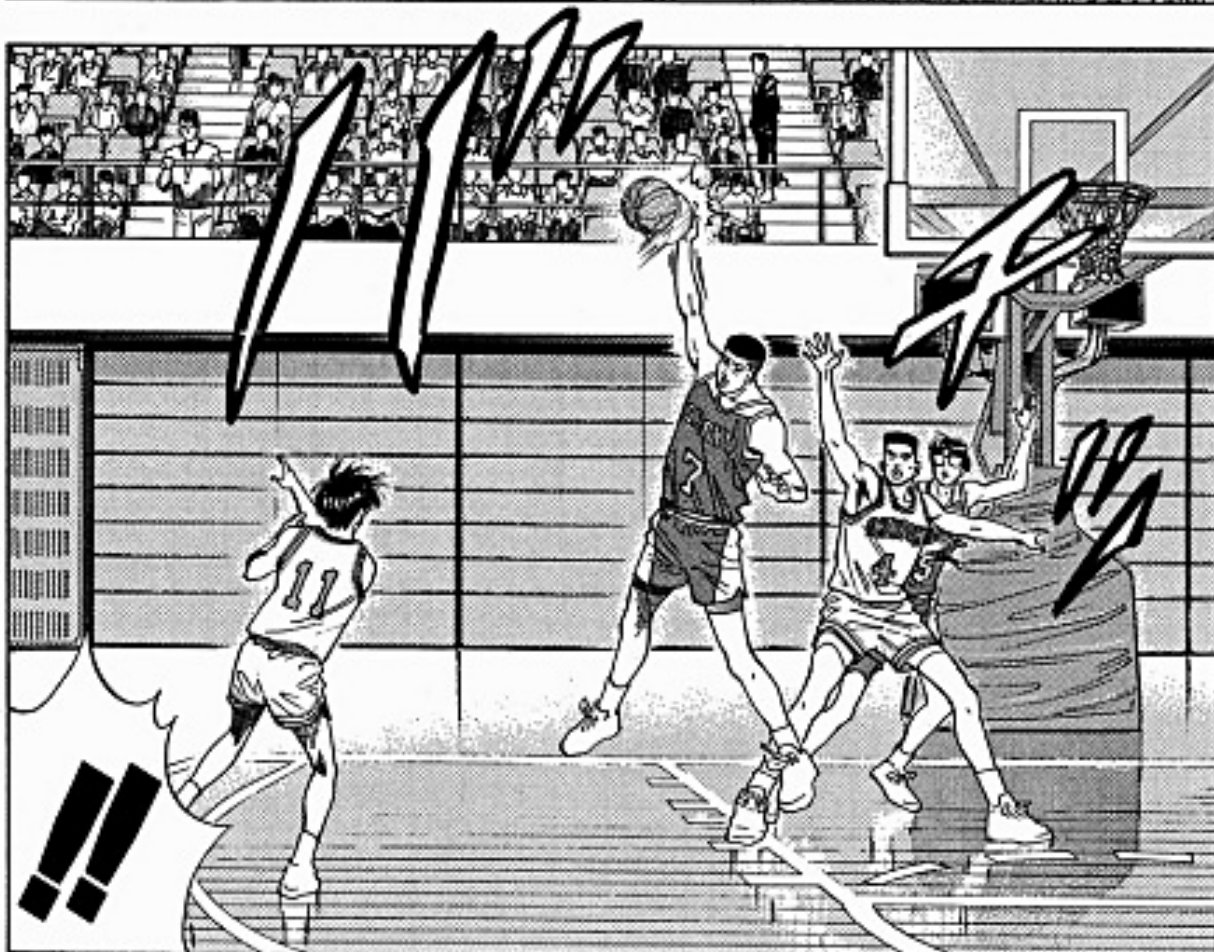

















visitanos en

<http://geniussubs.co.cc>

GENIUS-SUBS

**SLAM
DUNK**

capítulo 84:

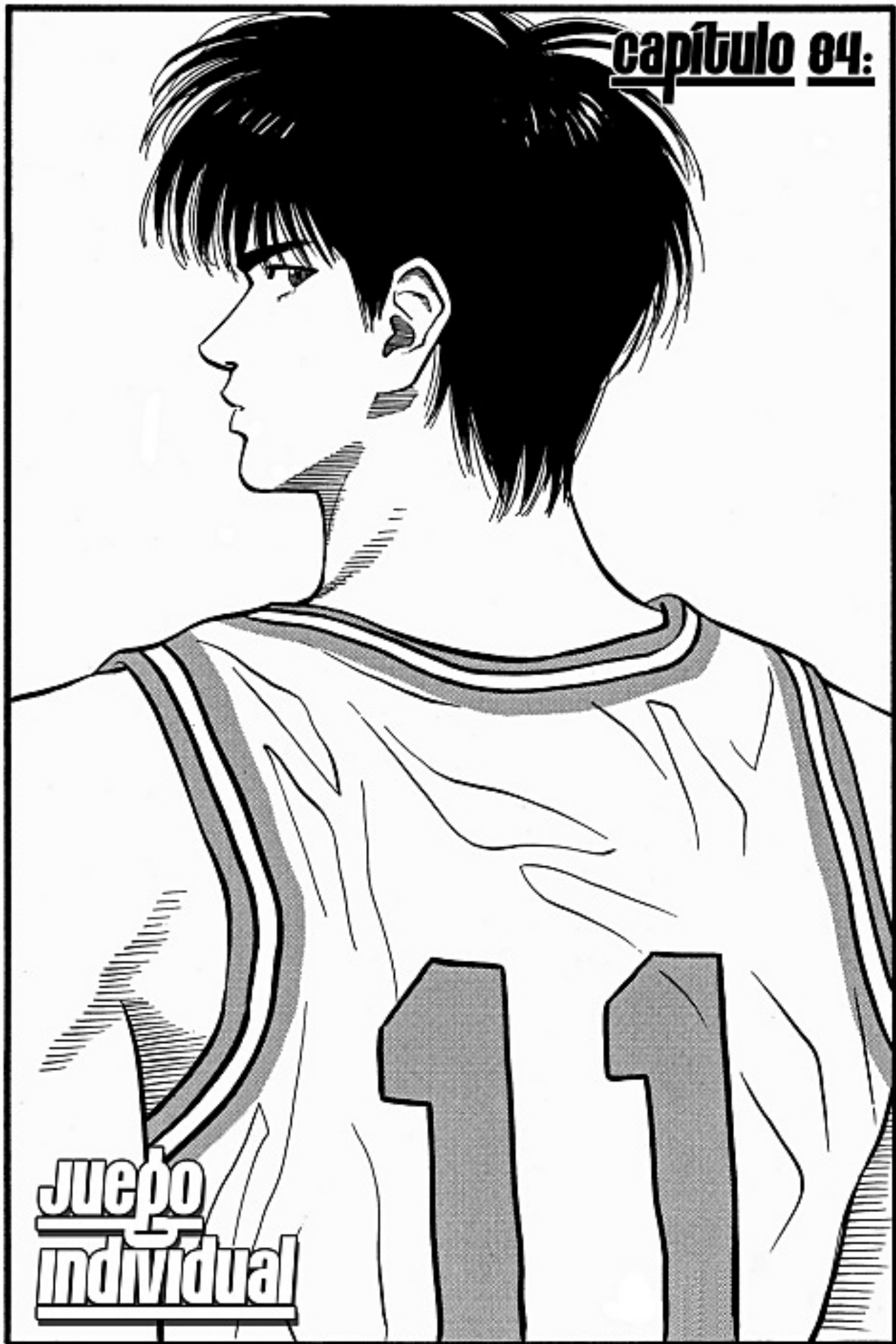

Juego
individual

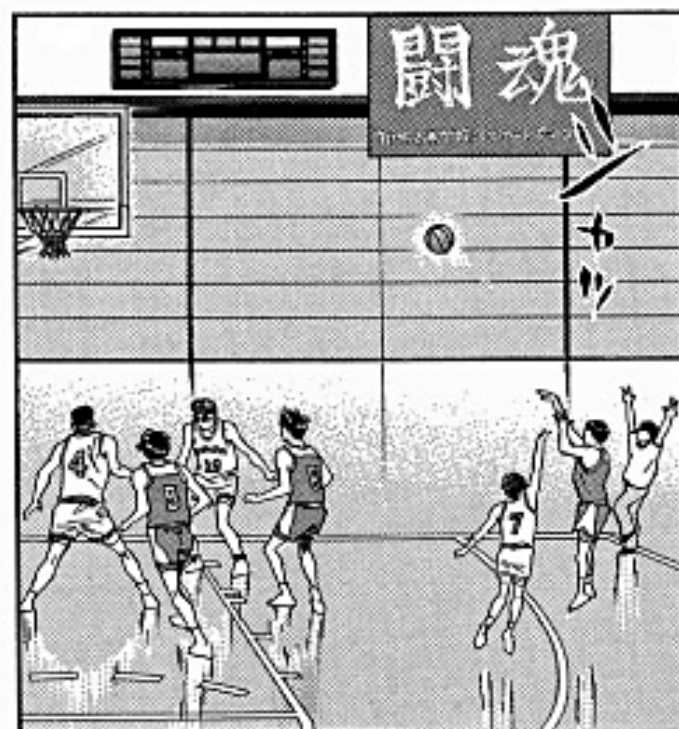
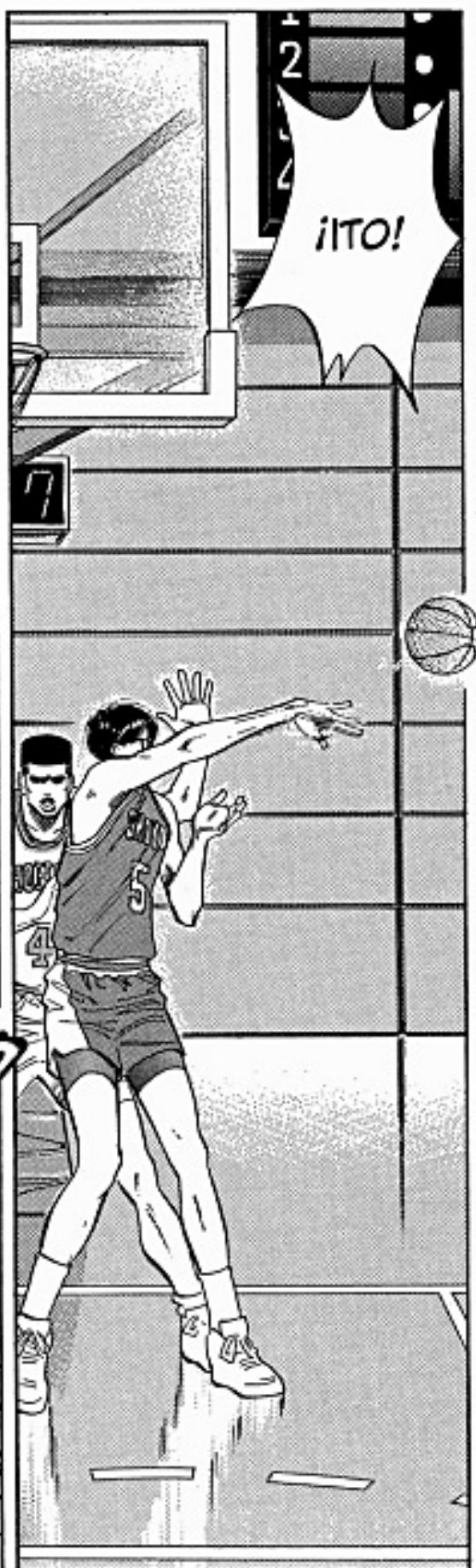



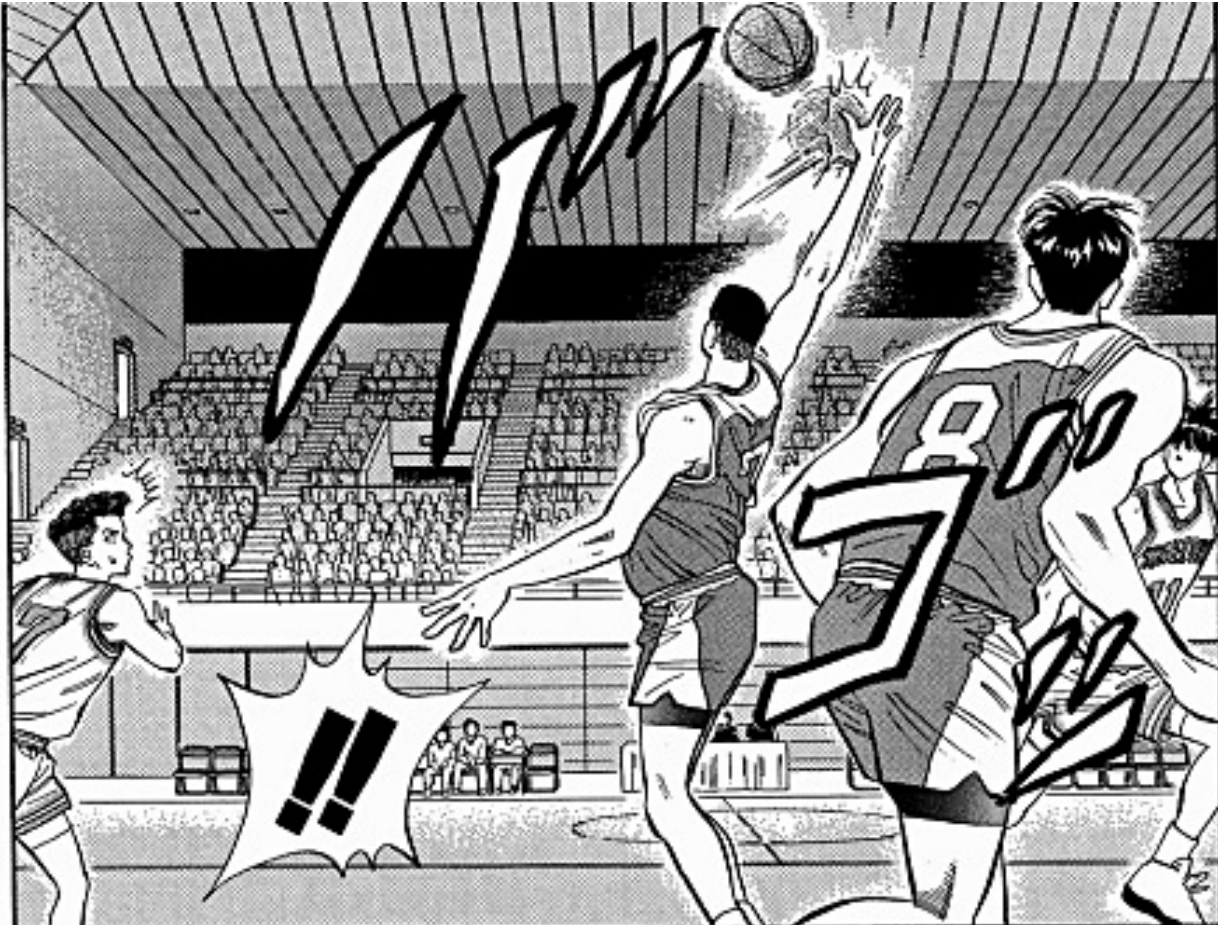

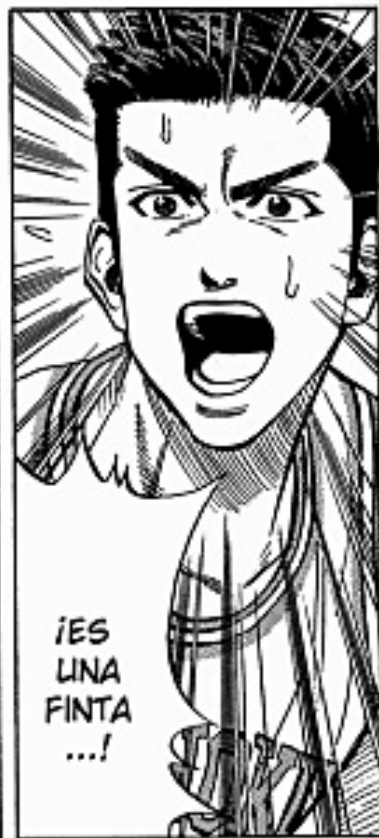
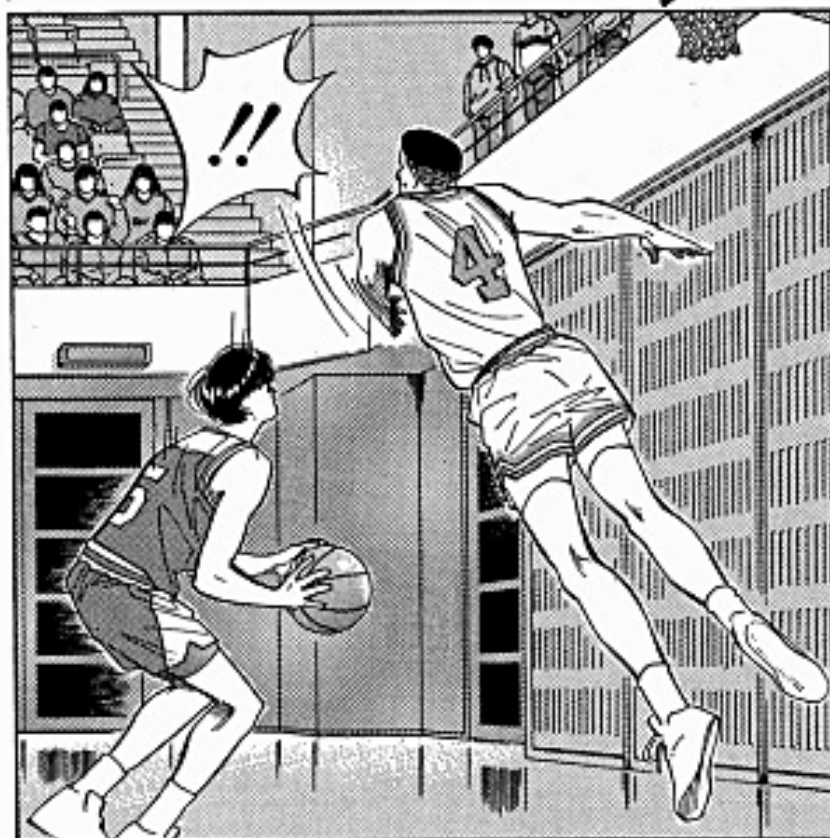

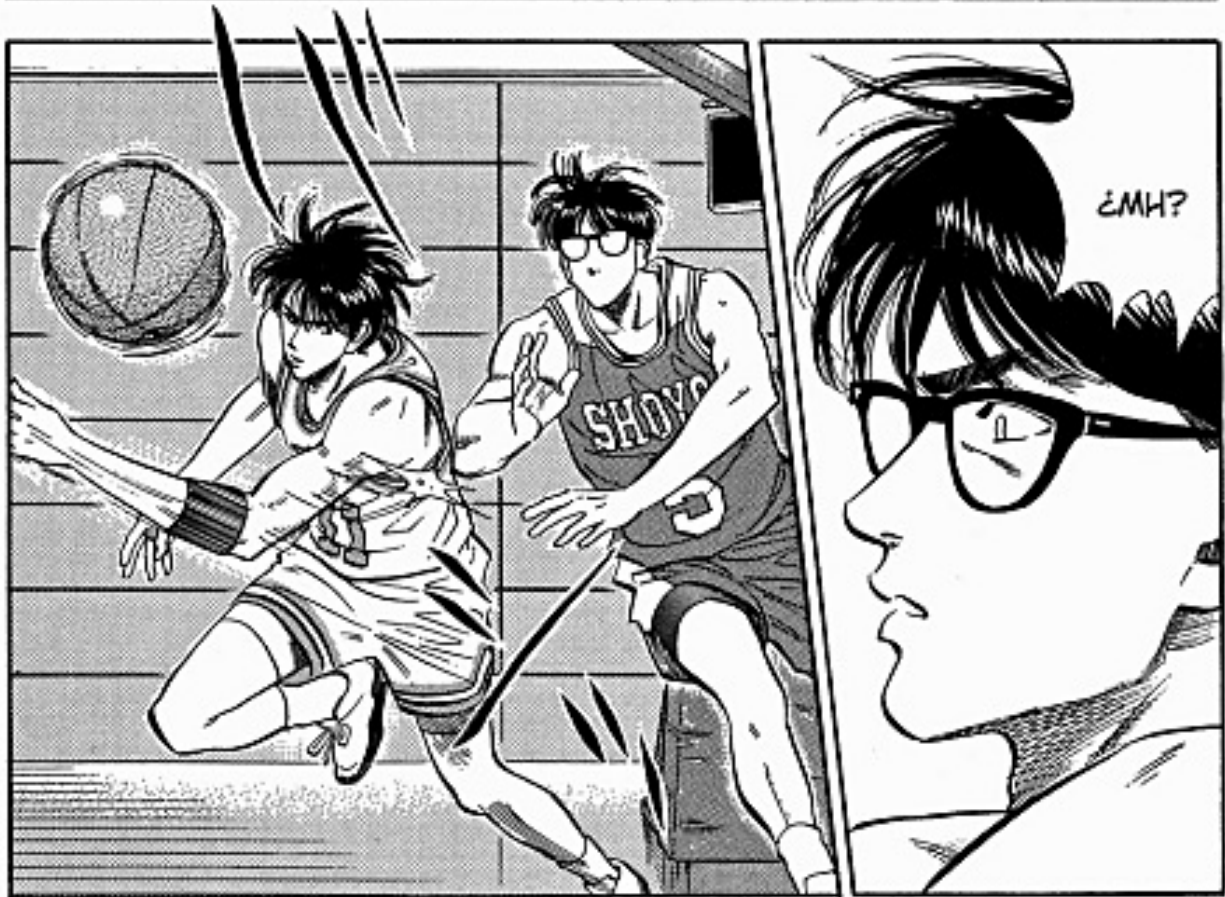
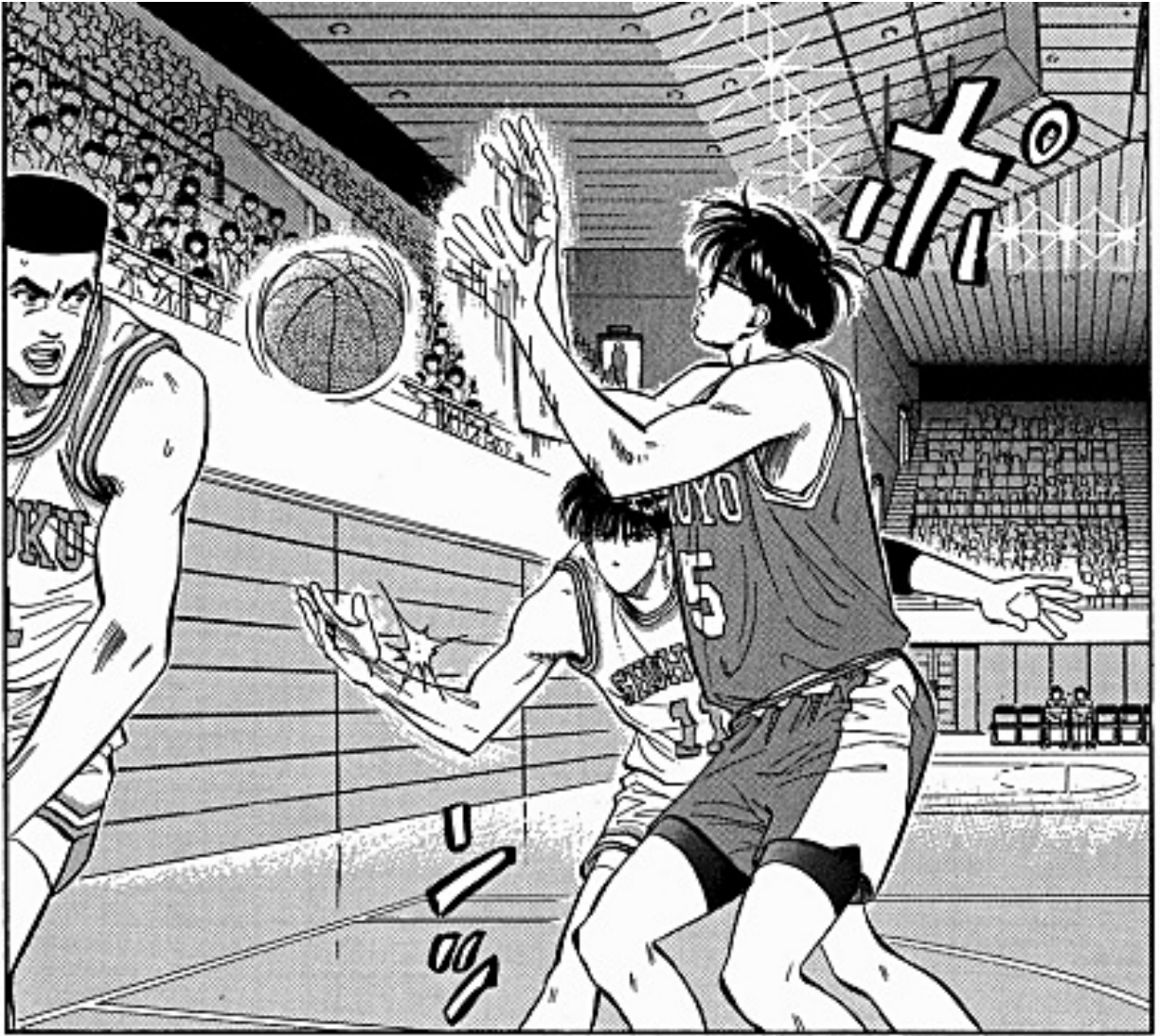

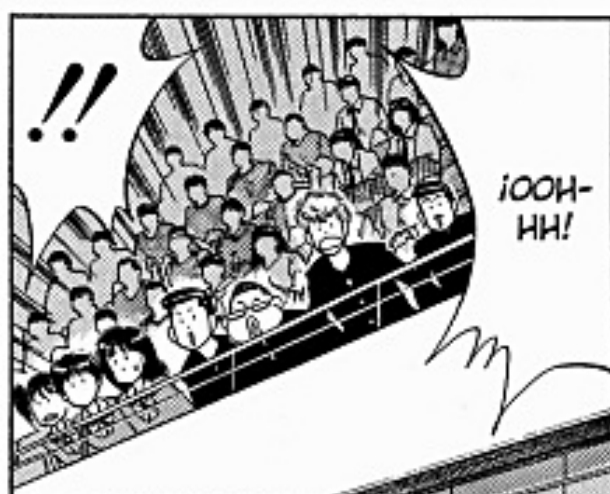

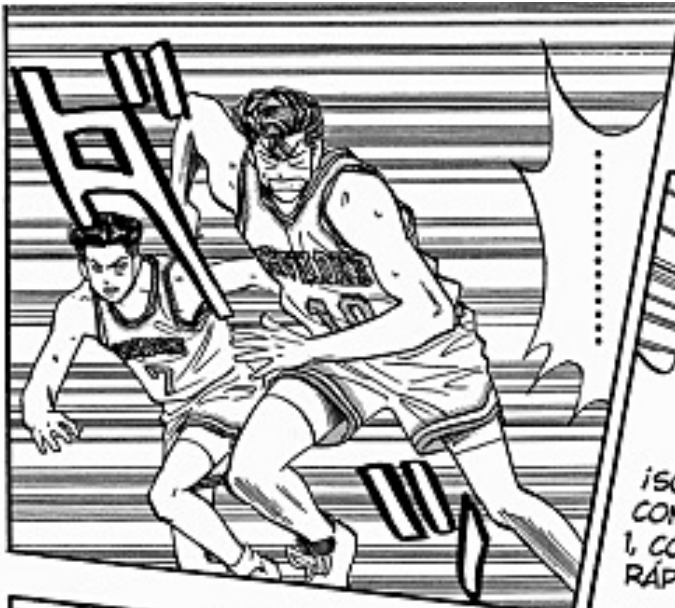

¡ESO ES, VAMOS, RUKAWA!

¡SON 3 CONTRA 1, CORRE RÁPIDO!



¡AWH!



¡ESPERA, RUKAWA!



¡DEJA DE QUERER LUCIRTE!

¡PASA EL BALÓN, IDIOTA!



GRR



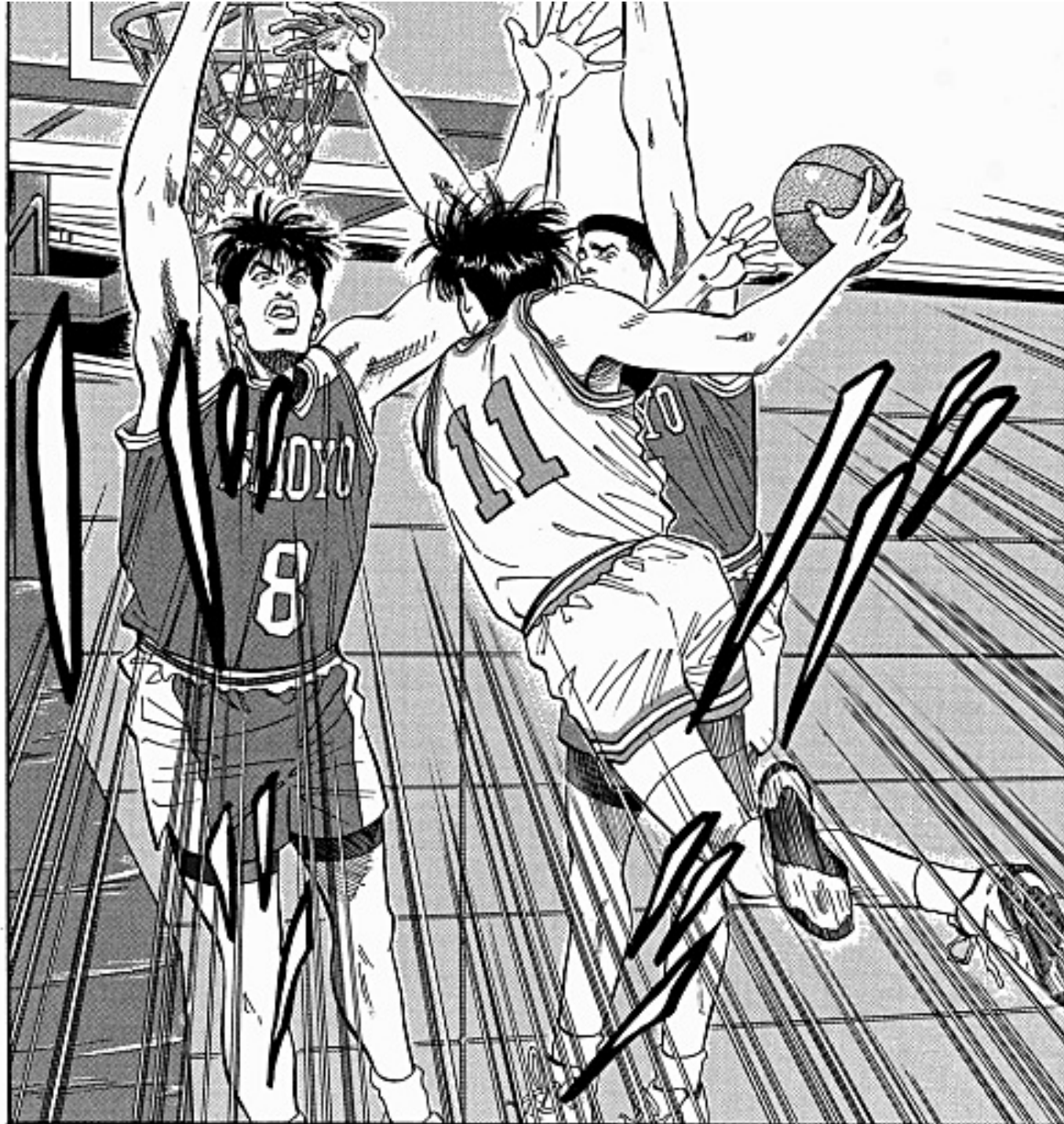

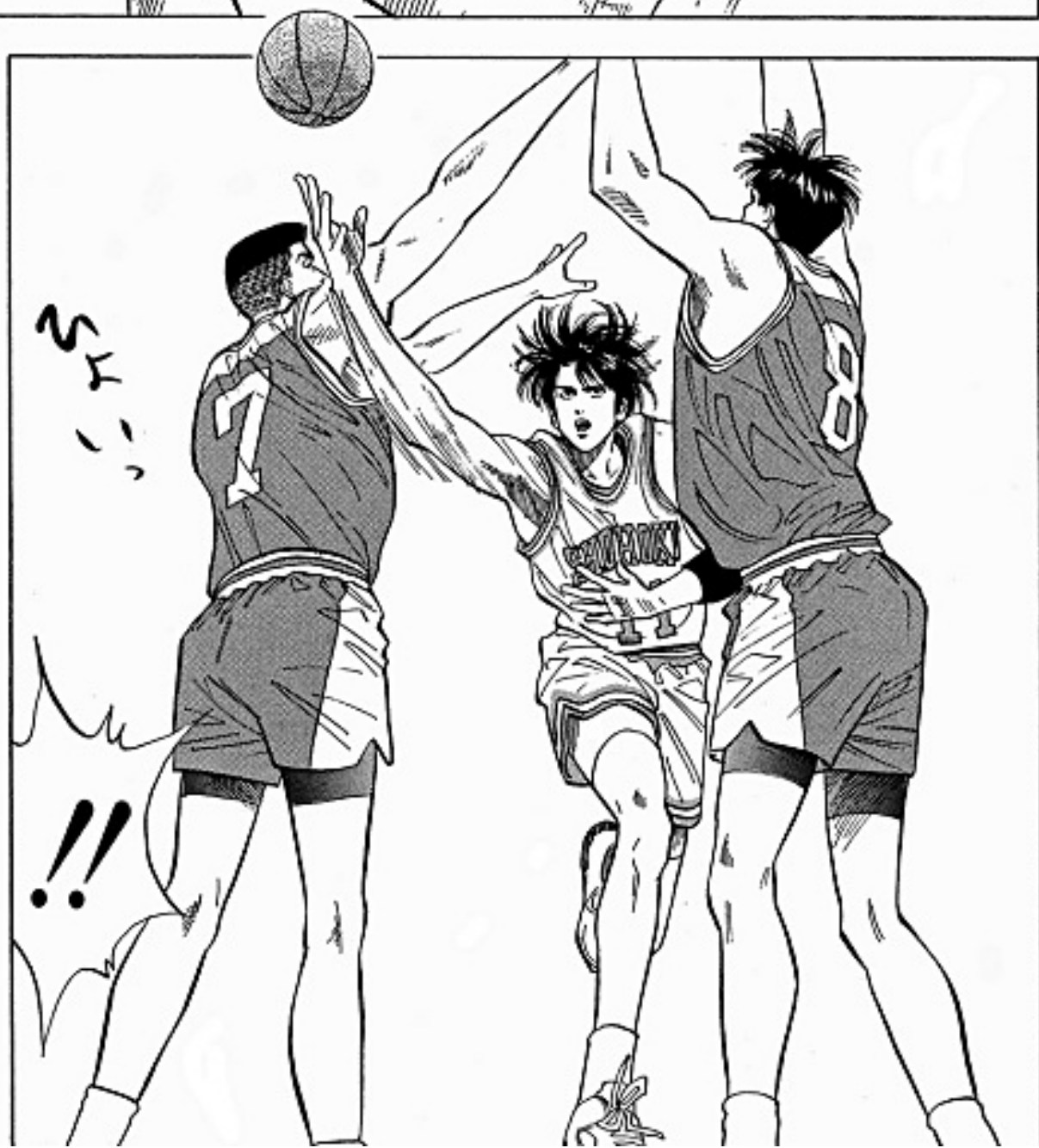

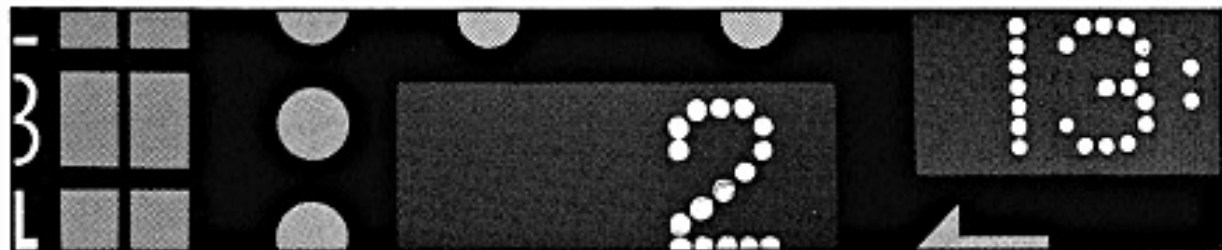
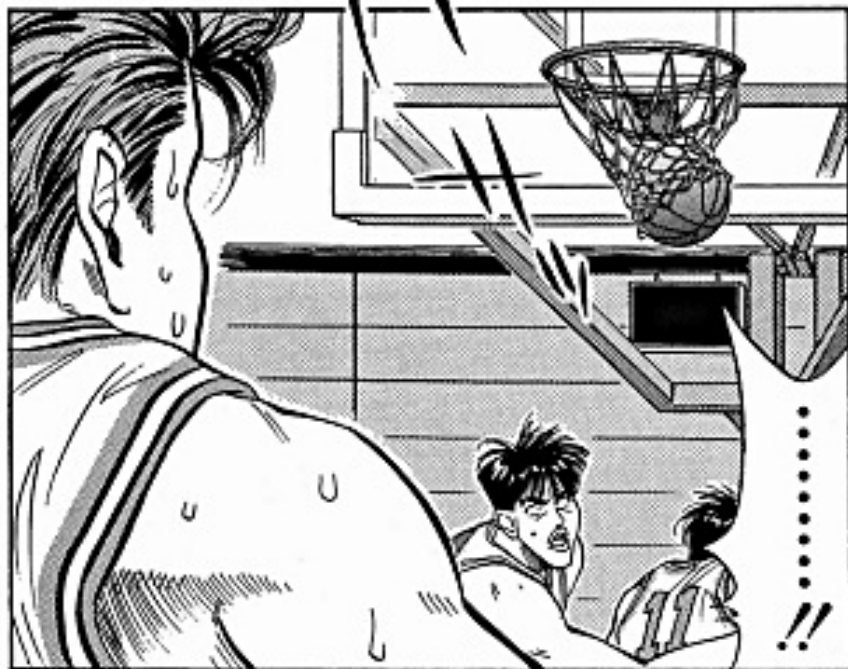





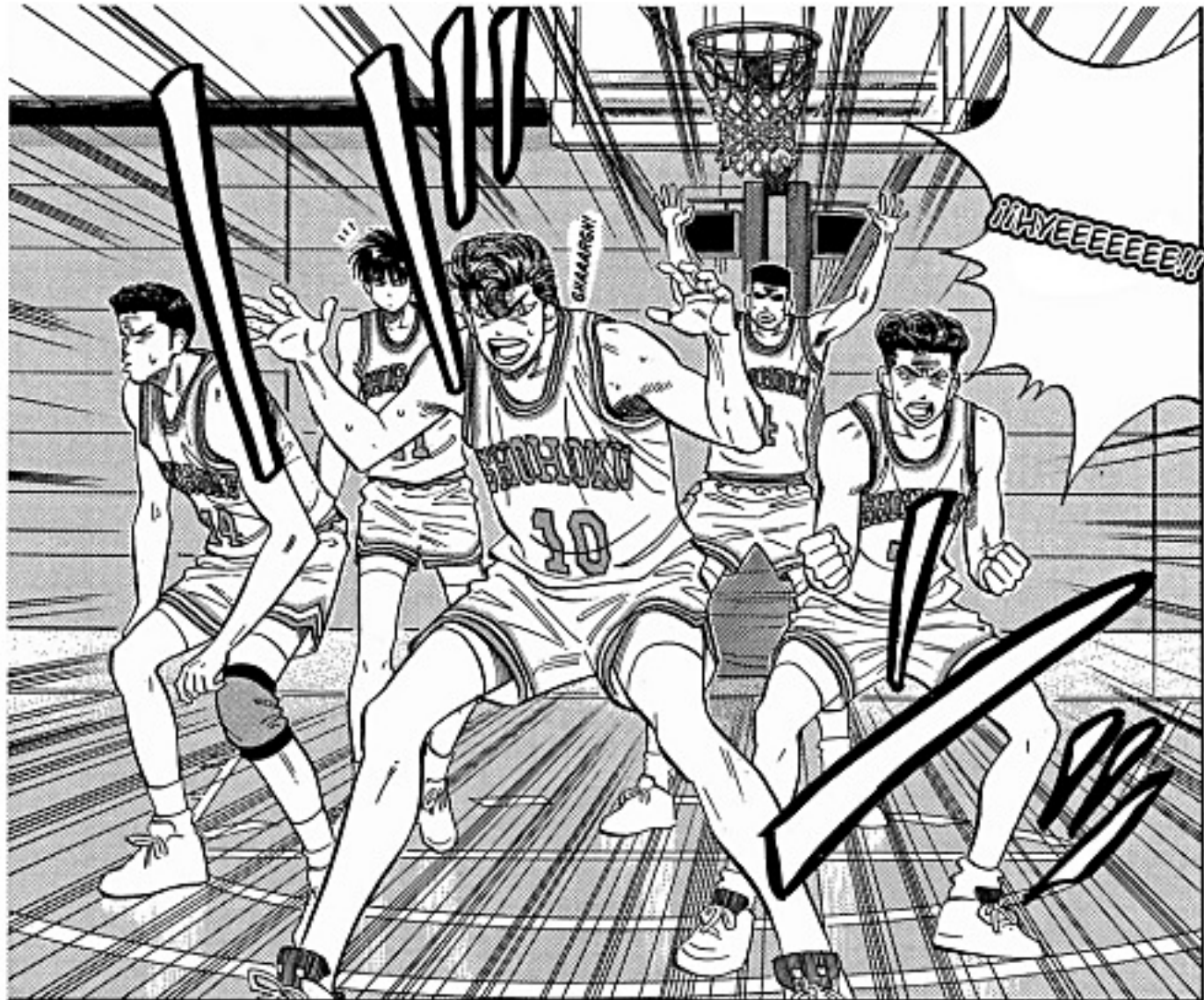



バチバチ!!

!!

ン





GENIUS·SUBS

visítanos en:

<http://geniussubs.co.cc>

**CORRECCIÓN Y
MONTAJE
MANAKA**

**TRADUCCIÓN
KAGEROYAMI
RED·HELLING
MANAKA**

**LIMPIEZA
ARIEL
JOPE
MANAKA
WURFANG**

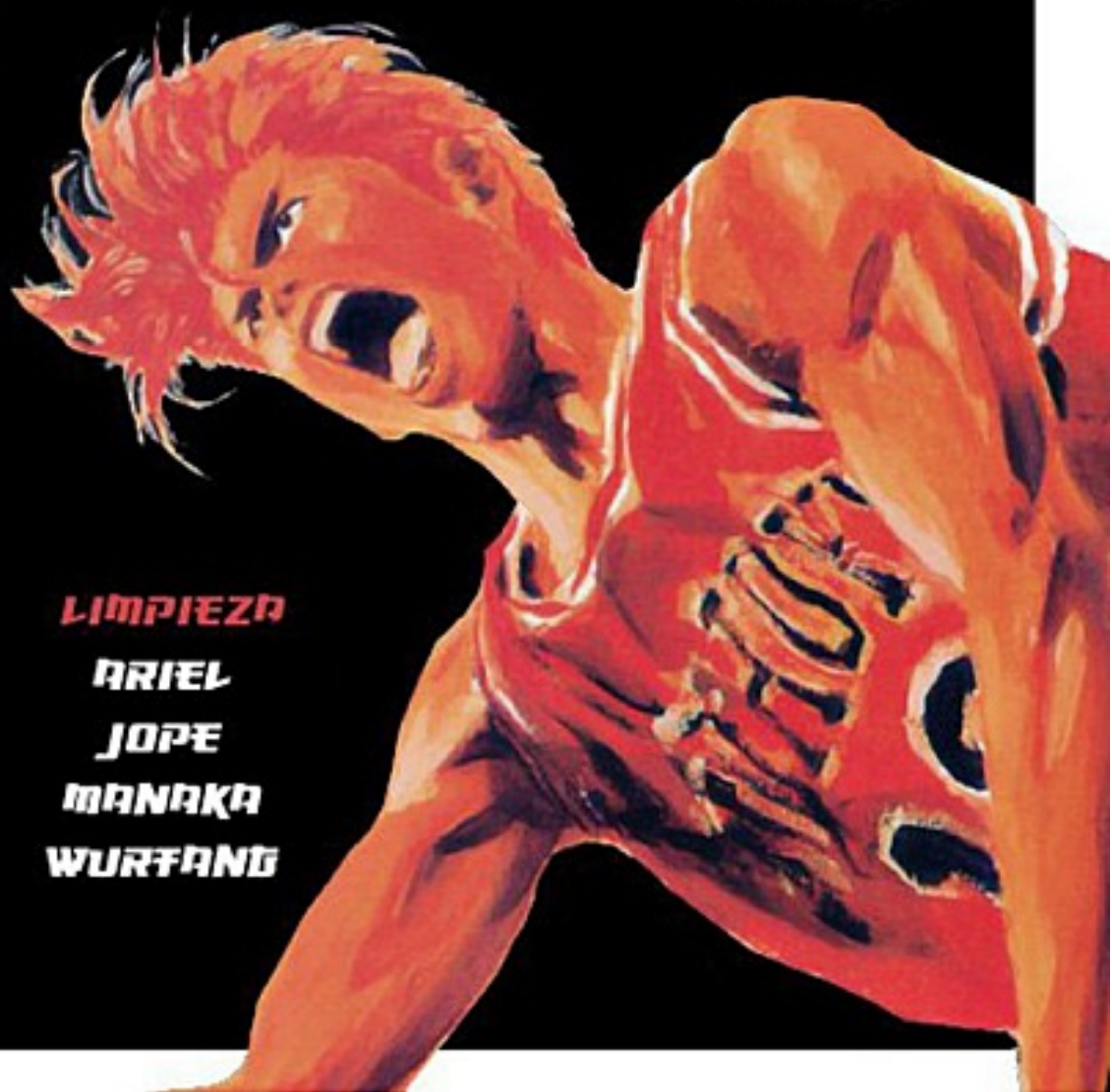

**SLAM
DUNK**

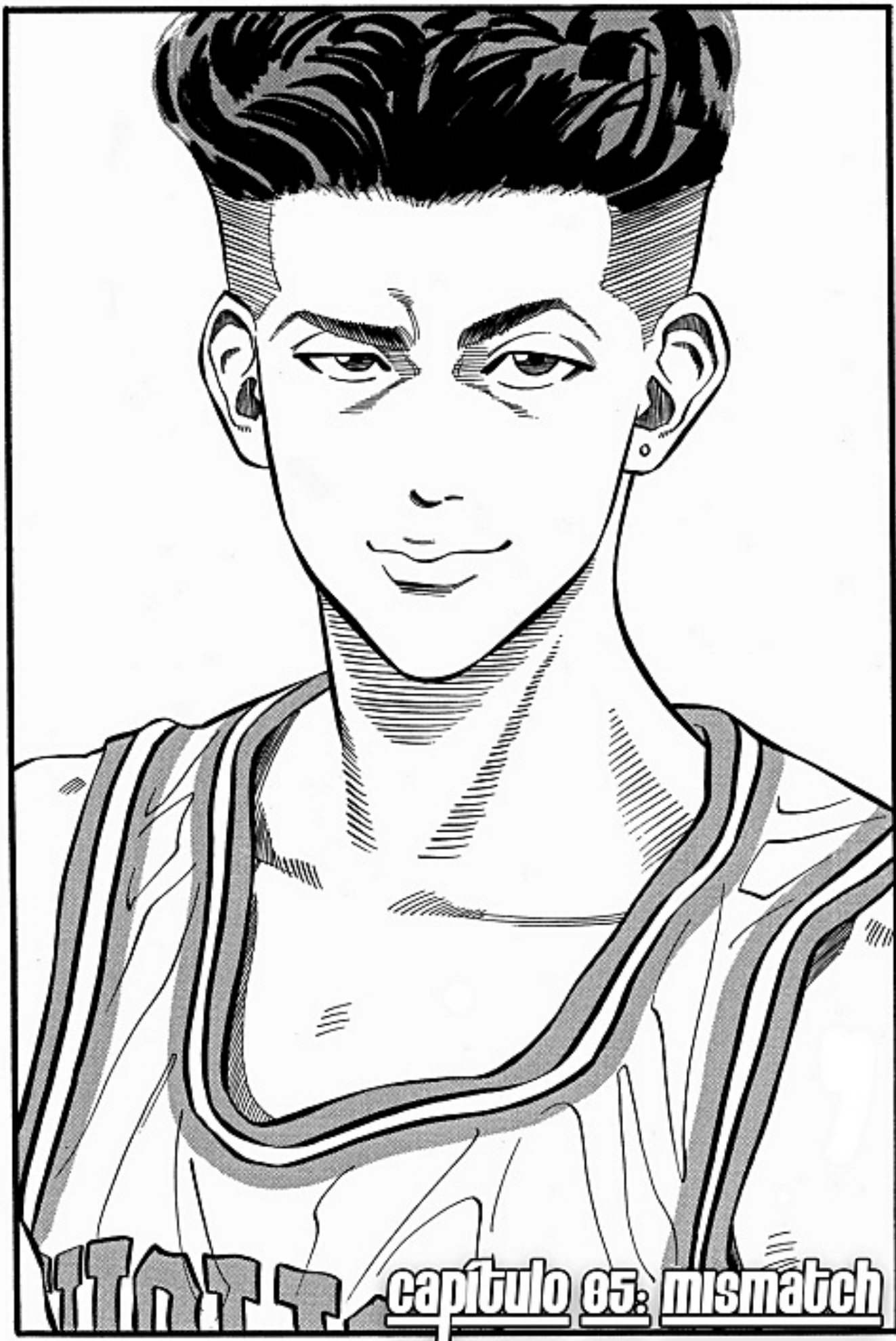



¡NUNCA ANTES VI QUE LOS BLOQUEEN!

¡BLOQUEARON A TAKANO Y HANAGATA, LOS DOS MÁS ALTOS DEL EQUIPO!

¡YAKAGI Y ESE EXTRAÑO SUJETO DE CABELLO ROJO...!

闘魂



¡SAPRE-DONANTE!

¡BUENOS BLOQUEOS!



¡VAMOS, MÁS RÁPIDO!

¡CONTRA-ATAGUE!



¡QUÉ BUENOS BLOQUEOS!

¡OO-OH-HHH!

¡LOS NUMEROS 10 Y 4 DE SHOHOKU!



¡KGH...!



¡ANOTARÉ
MÁS PUNTOS
QUE TÚ EN
ESTE JUEGO,
MUY PRONTO
LO VERÁS!

¡JAJAJA!
¿LO HAS
VISTO,
RUKAWA?



¡RYOTA,
PÁSAME EL
BALÓN!



¡MALDITA SEA,
NO PUEDO
CREEN QUE
ESE IDIOTA
PELIRROJO
...!



¡NO PUEDO
CREER QUE
LE DEN UN
PASE A
HANAMICHI!!

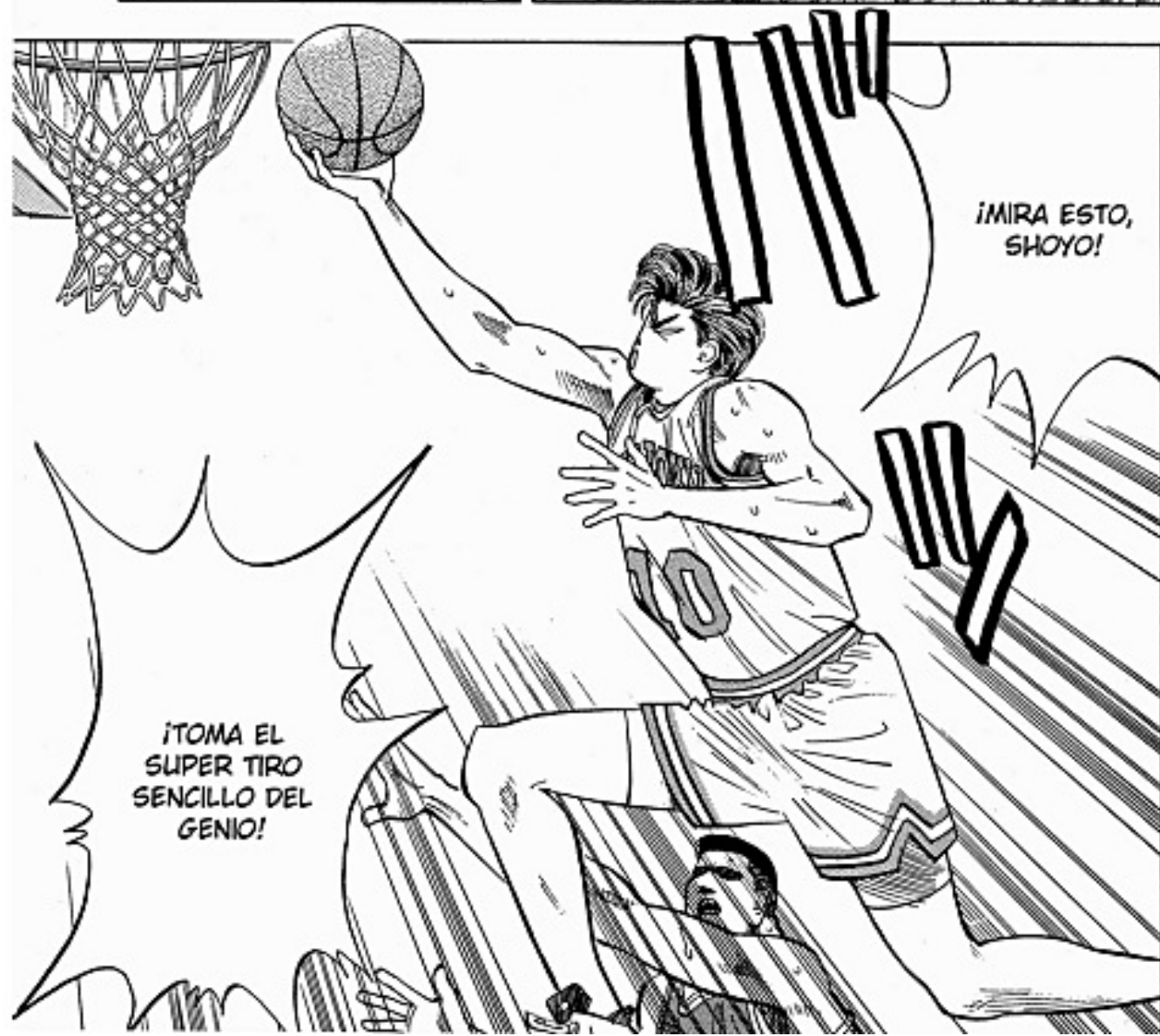

¡MIRA ESTO,
SHOYO!

¡TOMA EL
SUPER TIRO
SENCILLO DEL
GENIO!

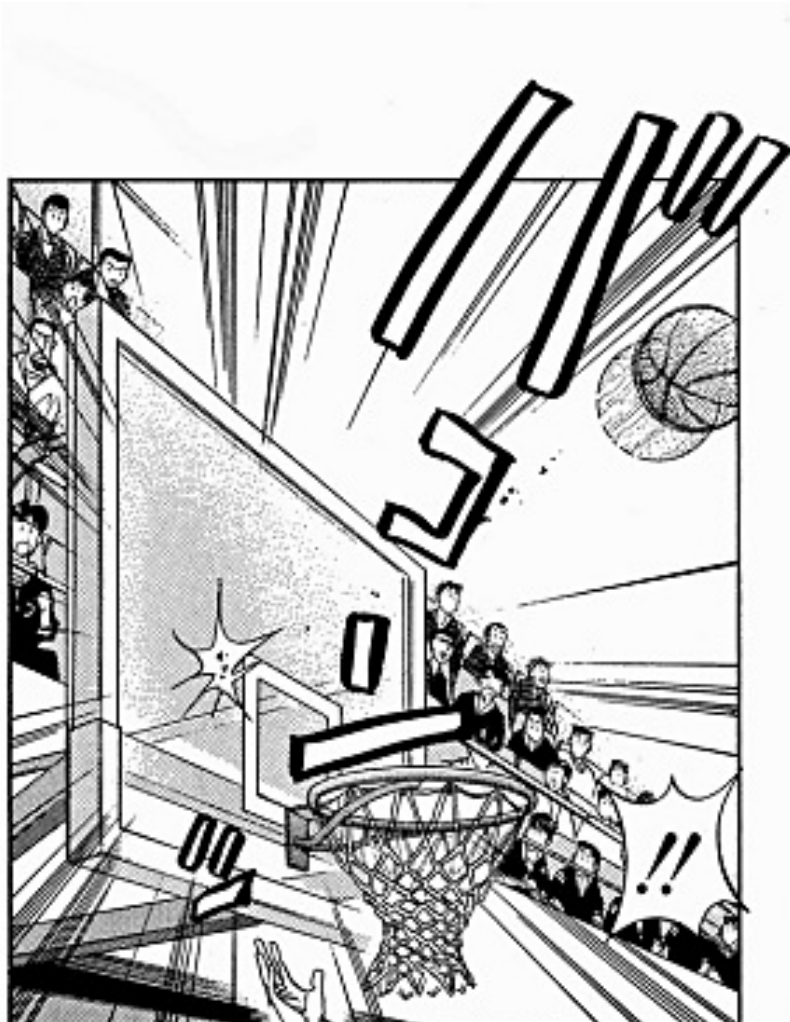





¡CÁLENSE
MALDITOS
ESTÚPIDOS!

¡ESO CUENTA
COMO UNA
ASISTENCIA!



¡CONCÉN-
TRATE,
ESTO NO
ES UN
SHOW,
HANA-
MICH!

¡VOY 2
CANASTAS
ATRÁS,
DEBO
ESFOR-
ZARME!

Sakuragi - 0 puntos

Rukawa - 4 puntos

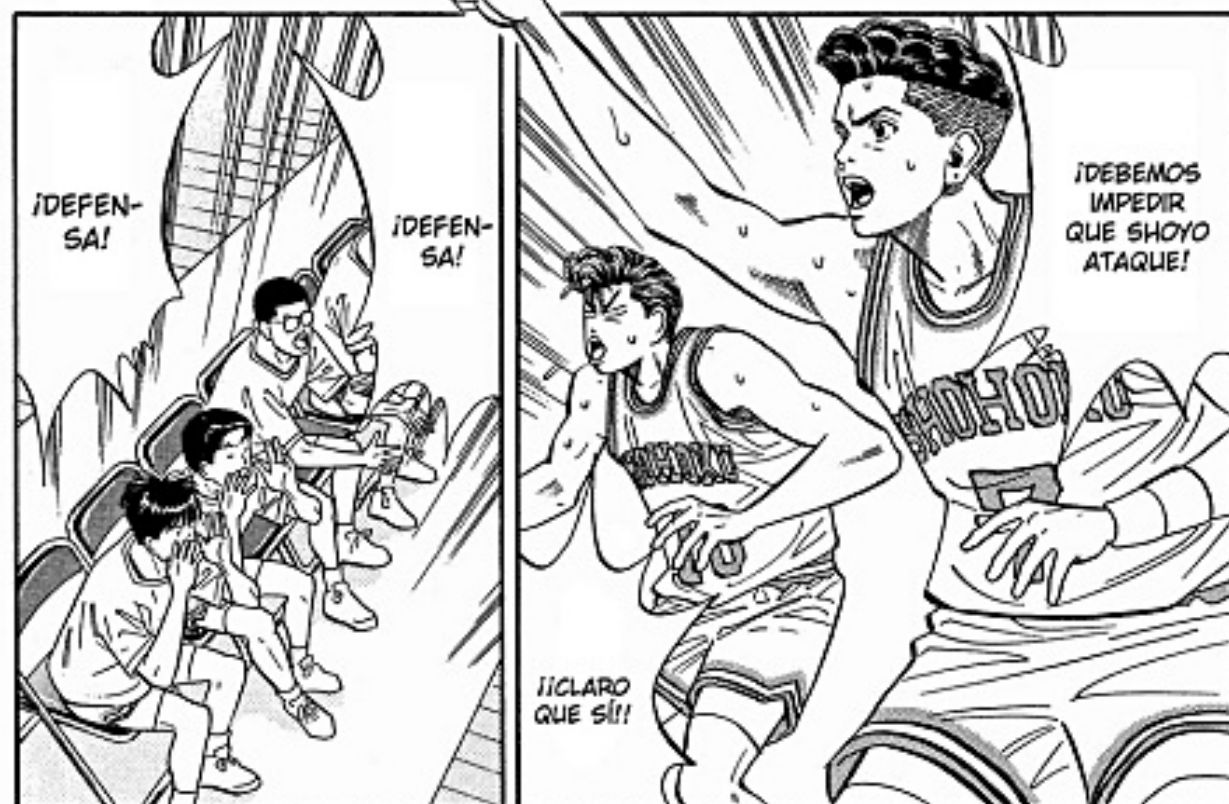

¡DEFEN-
SA!

¡DEFEN-
SA!

¡DEBEMOS
IMPEDIR
QUE SHOYO
ATAQUE!

¡¡CLARO
QUE SÍ!!



No importa lo mucho que me entrene, nunca podré tener su habilidad o su altura...





Traveling: desplazamiento ilegal con control de balón, se da cuando se salta y, antes de realizar un pase o tiro, se vuelve a pisar el suelo. o si se Desliza el pie de pivote por el suelo creando una ventaja





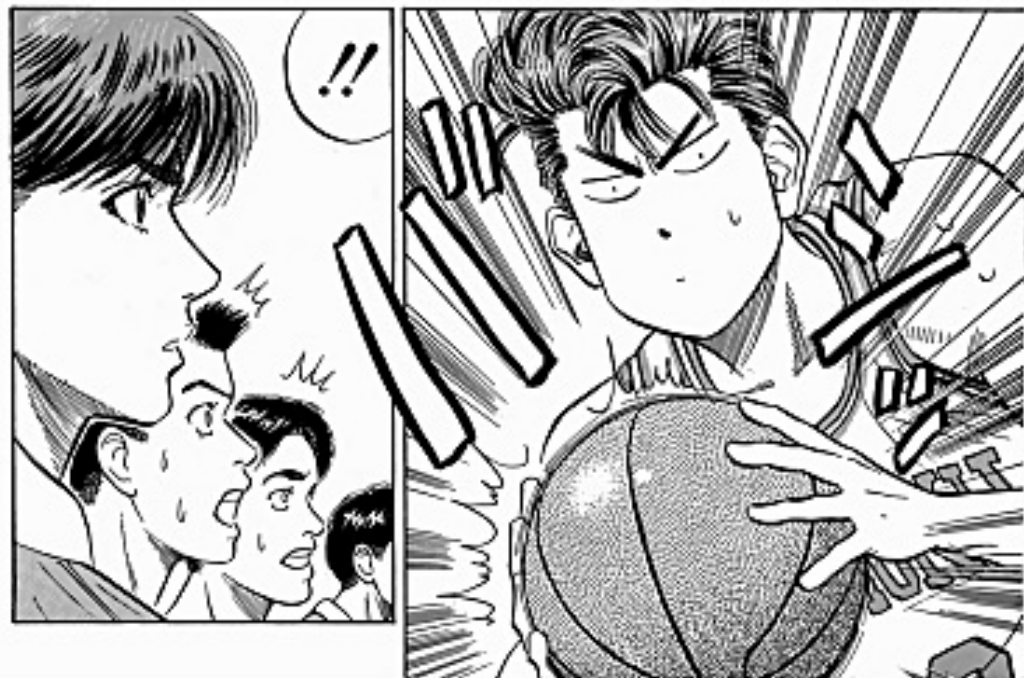

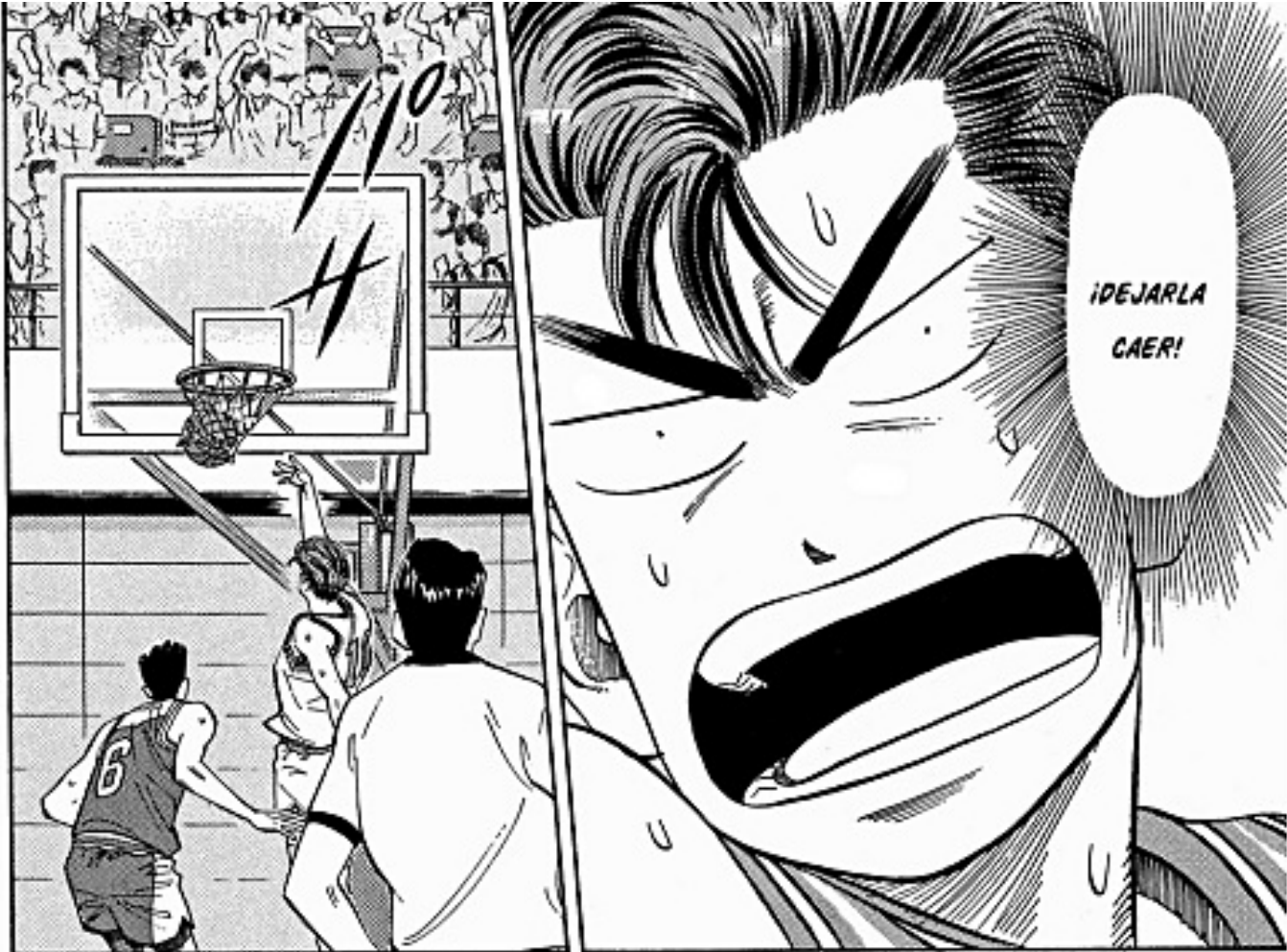

¡DEJARLA
CAER!

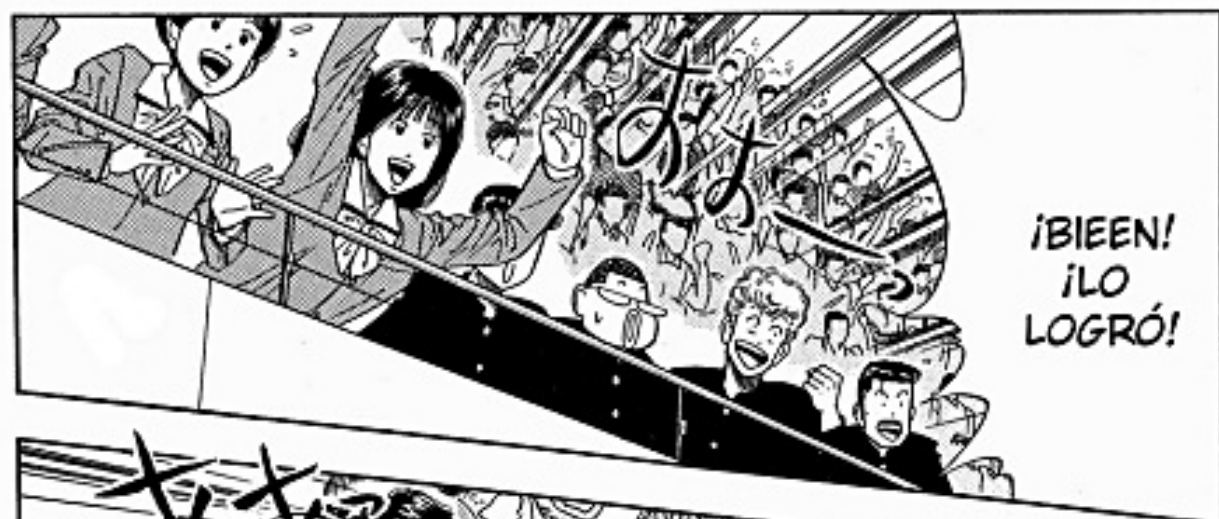

¡BIEN!
¡LO
LOGRÓ!



¡AH!

¡PERO
QUÉ
DEM...?!



¡PASÓ
SIN NADA
DE ESPA-
CIO!

¡WHOA!
¡INCREÍBLE
ASISTEN-
CIA!

¡ES MEJOR
QUE IR A
VER FUEGOS
ARTIFICIALES!



¡MIYAGI!



¡FUE
INCREÍ-
BLE!



¡ITO!

¡JAJAJA
JAJAJA!
¡ÉLO HAN
VISTO?!





¡VAMOS,
MUCHACHOS,
ANOTEMOS
UN TANTO
MÁS!



¡TÚ
PUEDES,
MIYAGI!

¡WHOA,
INCREÍ-
BLE!



Genius-sub

visítanos en:

<http://geniussubs.co.cc>

Corrección y
montaje
Manaka

Traducción:
Kageroyami
Red-Hellin;
Manaka

Limpieza:
ariel
jope
manaka
wurtang

**SLAM
DUNK**

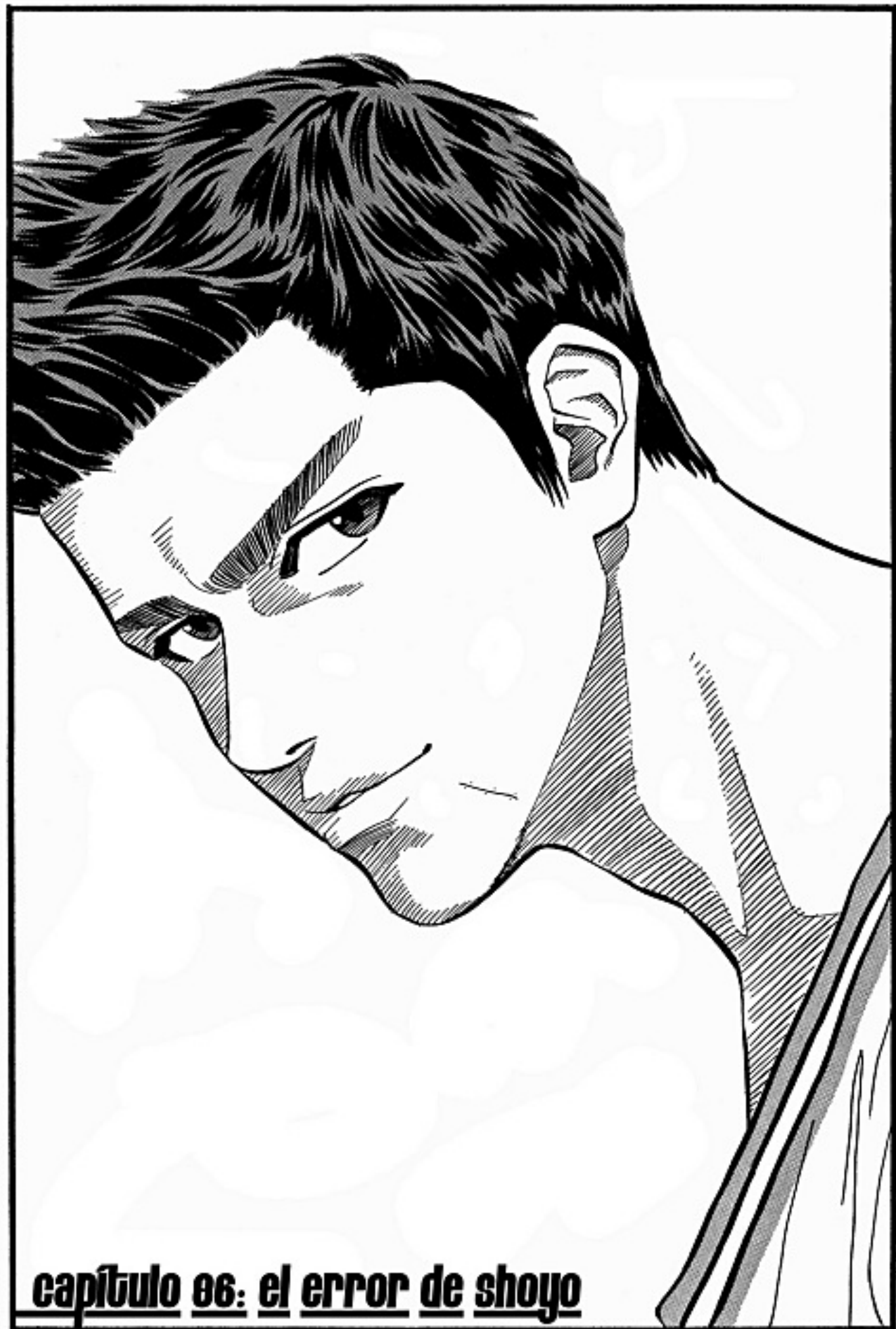

capítulo 06: el error de shoyo





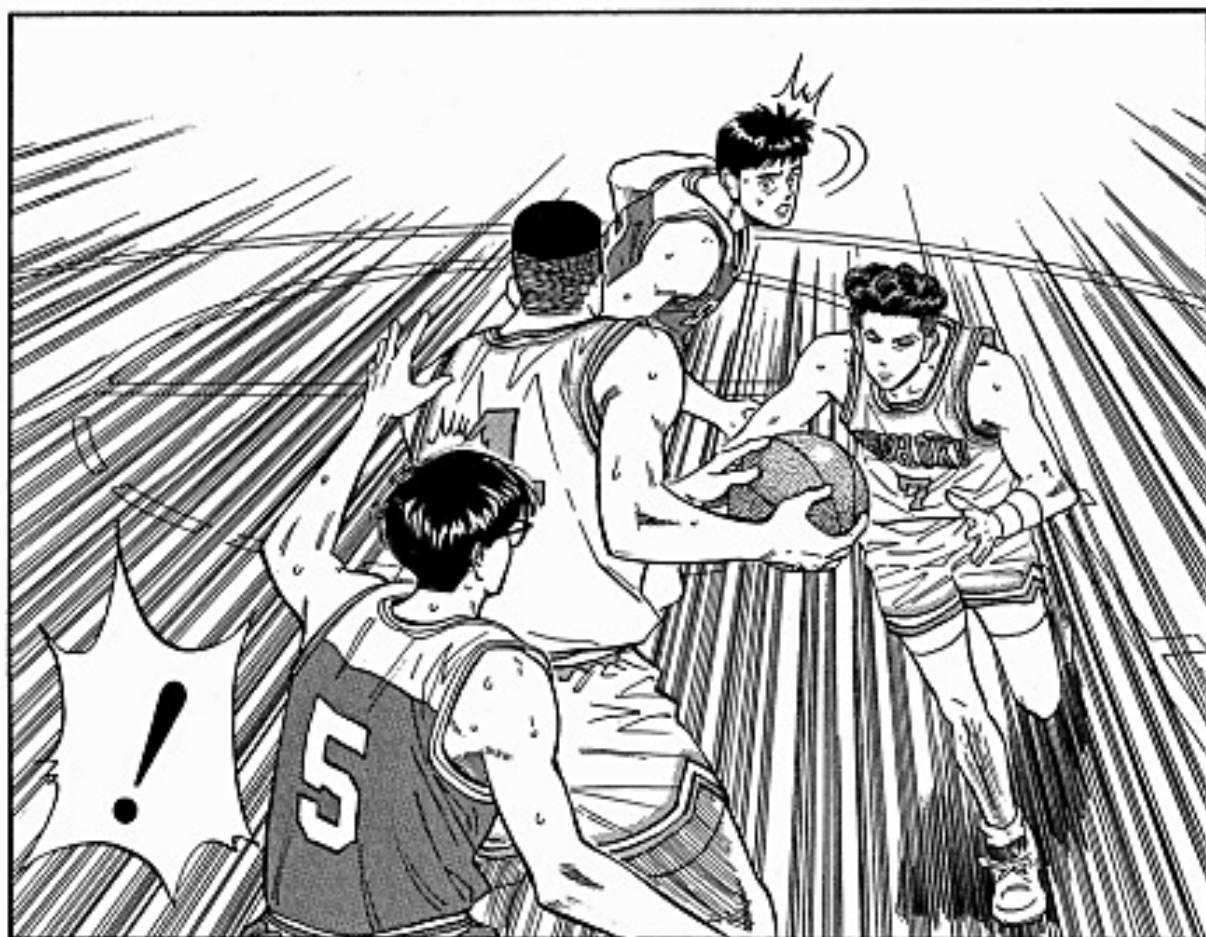



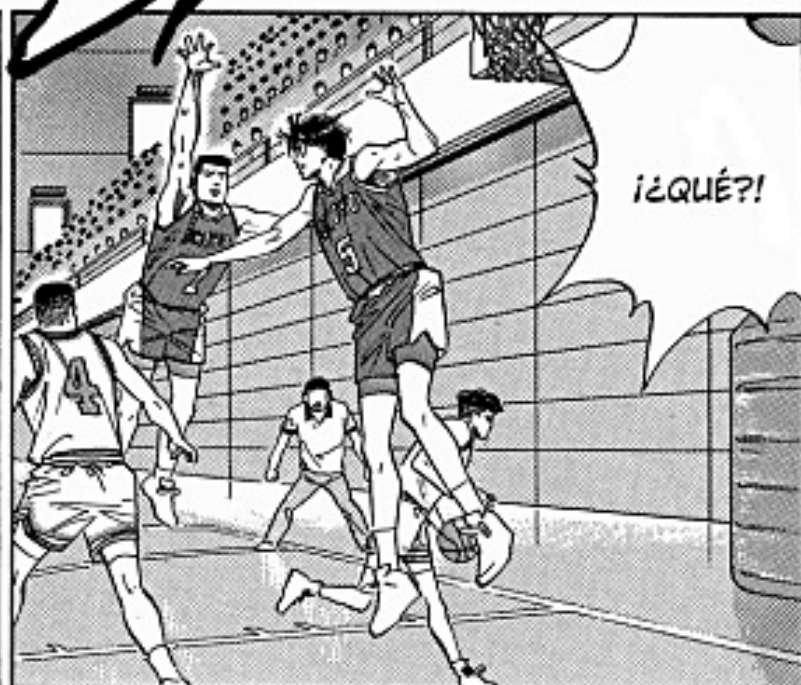

¡WAAAAAH!





¡SHOHOKU
CASI ESTÁ
MUY CERCA
DE IGUALAR
EL MARCA-
DOR!

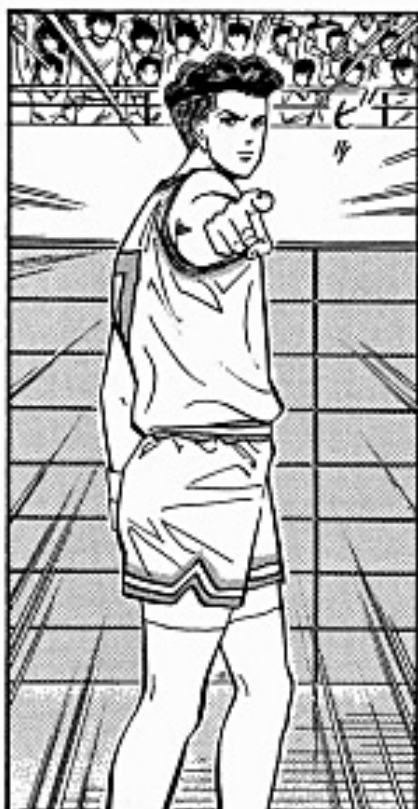





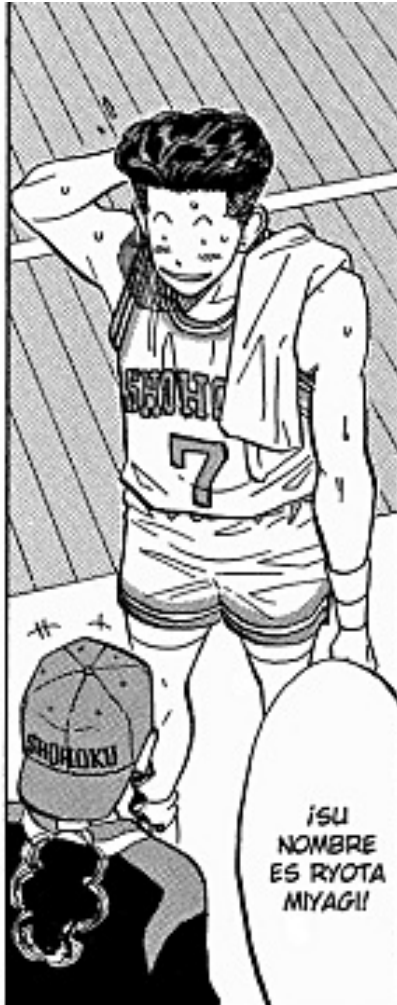



TODO DEPENDE DE TI

HANA-GATA



BIEN, REGRESEN AL JUEGO

¡Y RECUERDEN QUE ESTE AÑO, SHOYO SERÁ EL Nº1...!



¡¡¡¡!





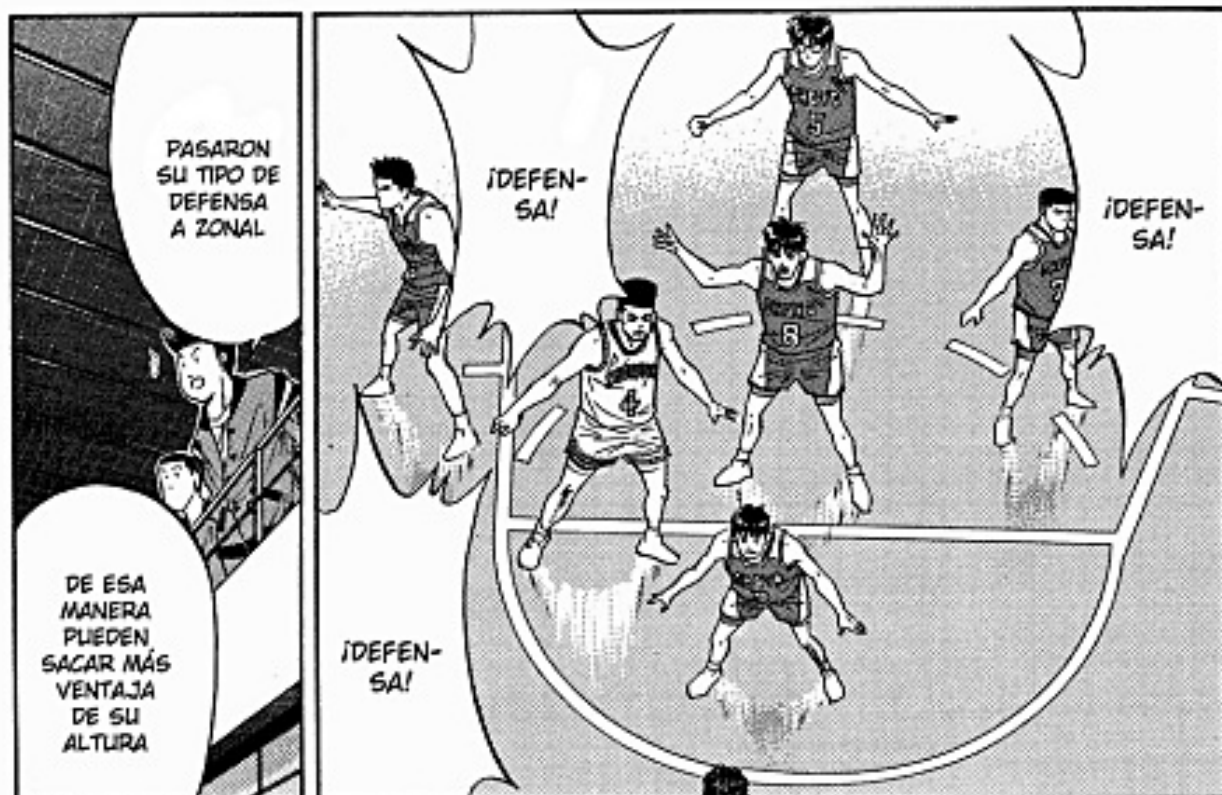

PASARON SU TIPO DE DEFENSA A ZONAL

DE ESA MANERA PUEDEN SACAR MÁS VENTAJA DE SU ALTURA

¡DEFENSA!

¡DEFENSA!

¡DEFENSA!



5 !!

4 !!

3 !!

¡YA CASI SE ACABAN LOS 30 SEGUNDOS!



USAN SU ALTURA PARA MARCAR ZONALMENTE EL CENTRO, CREANDO UNA PARED EN ESE LUGAR ...

ESTA ESTRATEGIA DE FUJIMA ES LA MÁS ACERTADA PARA ESE TIPO DE ATAQUE, PERO...



¡UGH!

SIN EMBARGO, CON ESTE TIPO DE DEFENSA SHOYO PODRÁ PARAR TODOS LOS CONTRAATAQUES DE SHOHOKU

AKAGI NO SE HA DADO POR VENCIDO CON EL MODO DE ATAQUE QUE VENÍA USANDO

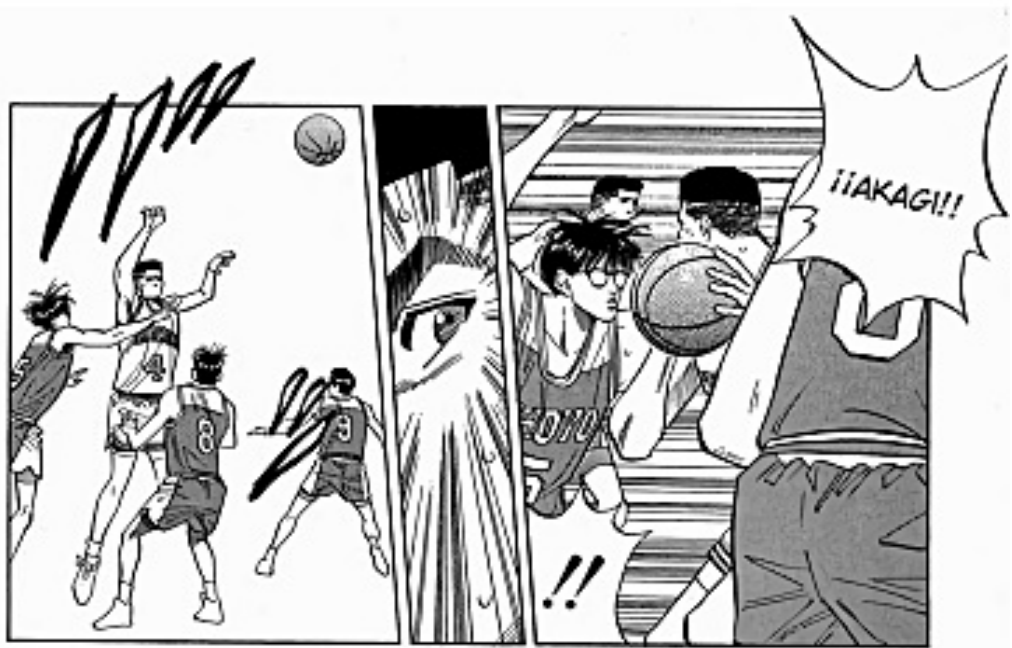





¡HEMOS EMPATA-
DO...!

¡BUEN
TIRO,
MITSUI!



¡AHORA
LA DEFENSA
DE SHOYO
TENDRÁ QUE
ABRIRSE!

¡AUNQUE
SHOYO CUBRA
ZONALMENTE
EL CENTRO,
MITSUI PUEDE
TIRAR DESDE
AFUERA!



JUSTO
COMO LO
PENSÉ...



¡¡FUJIMA
ESTÁ POR
ENTRAR!!

**SLAM
DUNK**



**capitulo 87:
la primera
mitad termina**

¡HEMOS
PODIDO
EMPATAR
...!

¡SHOHOKU
LO HA
ALCANZADO!



HACE
3 AÑOS
...

UN TIRO
SUYO LE
DIO LA
VICTORIA
A SU
EQUIPO



SU
PEINADO
ES DIFE-
RENTE...
PERO ES
EL...



¿CONO-
CES
A ESE
Nº14?

¿MITSUI?
¿ESE ES
HISASHI
MITSUI?!



ÉL ERA
EL N°14 DE
LA ACADEMIA
TAKEISHI, EL
EQUIPO QUE
GANÓ EL
CAMPEONATO
DE SECUNDARIA
INFERIOR

¡ES EL
MVP,
HISASHI
MITSUI!



¿TANTO
ALBOROTO
POR SÓLO
UN TIRO?

TSK



¡¡AHH!!

¿ESI ESTÁ
JUGANDO
EN SHOHOKU,
POR QUÉ
NUNCA LO
HABÍAMOS
VISTO?!

¡HISASHI
MITSUI!

¿SEGU-
RO?

¿ESE ES
MITSUI?

¡SHOHOKU
RESULTÓ
SER UN
MUY BUEN
EQUIPO!

ES UN
ARMA
SECRE-
TA...

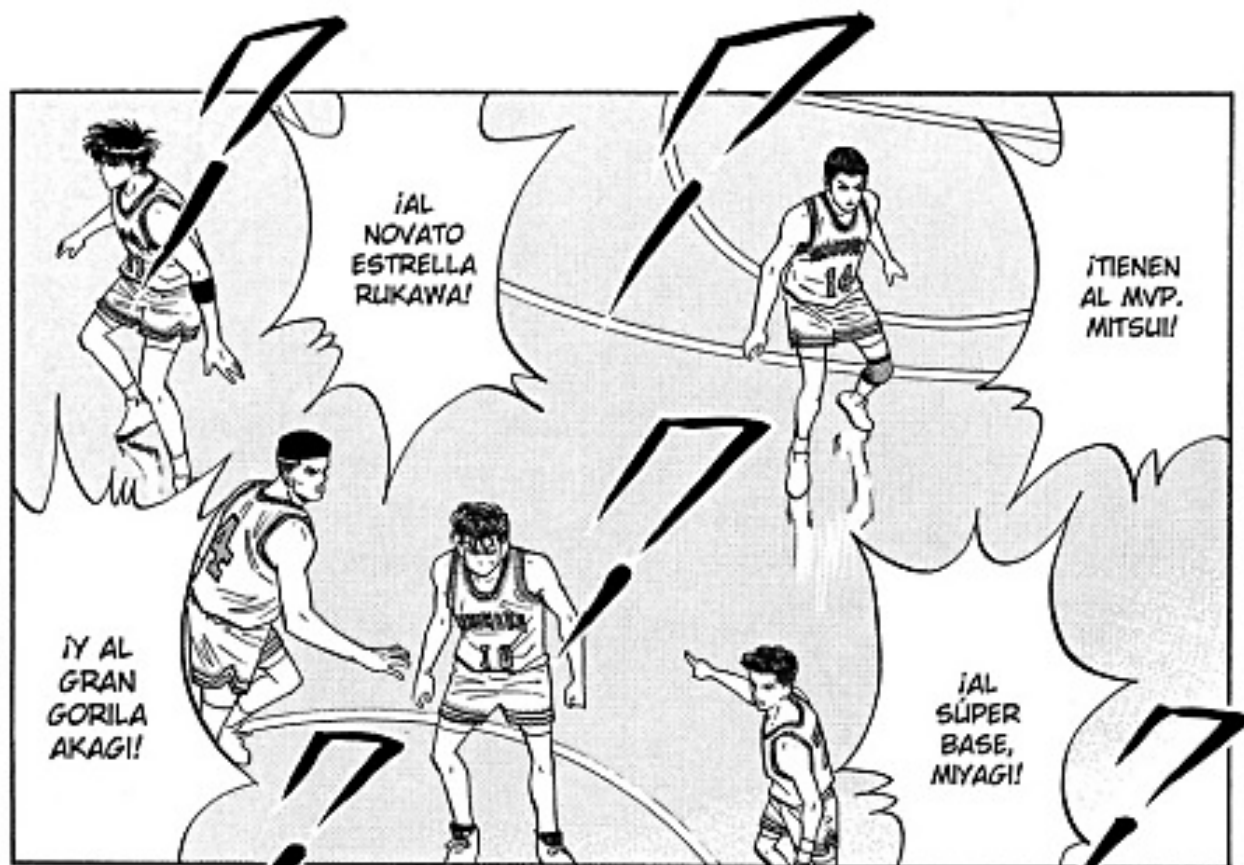

¡AL
NOVATO
ESTRELLA
RUKAWA!

¡TIENEN
AL MVP.
MITSUI!

¡Y AL
GRAN
GORILA
AKAGI!

¡AL
SÚPER
BASE,
MIYAGI!



¡ES
REALMENTE
UN EQUIPO
MUY FUERTE
...!

¡AKAGI,
RUKAWA,
MIYAGI Y
MITSUI!



¡TENGO
MÁS HABILIDAD
QUE LOS OTROS
Y JUNTOS!

¡MALDICIÓN,
YO SOY EL GRAN
GENIO DEL
BASKETBALL!



¡SE
OLVIDAN
DEL GRAN
GENIO,
SAKURAGI!

¡HEY,
ESPEREN
UN SE-
GUNDO!

¡AHÍ
VIENEN,
SAKU-
RAGI!











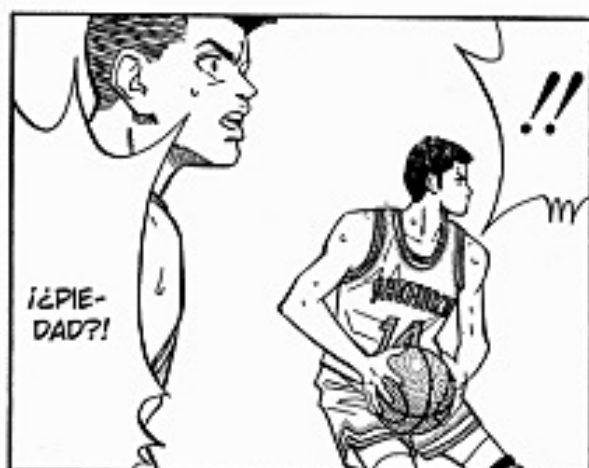
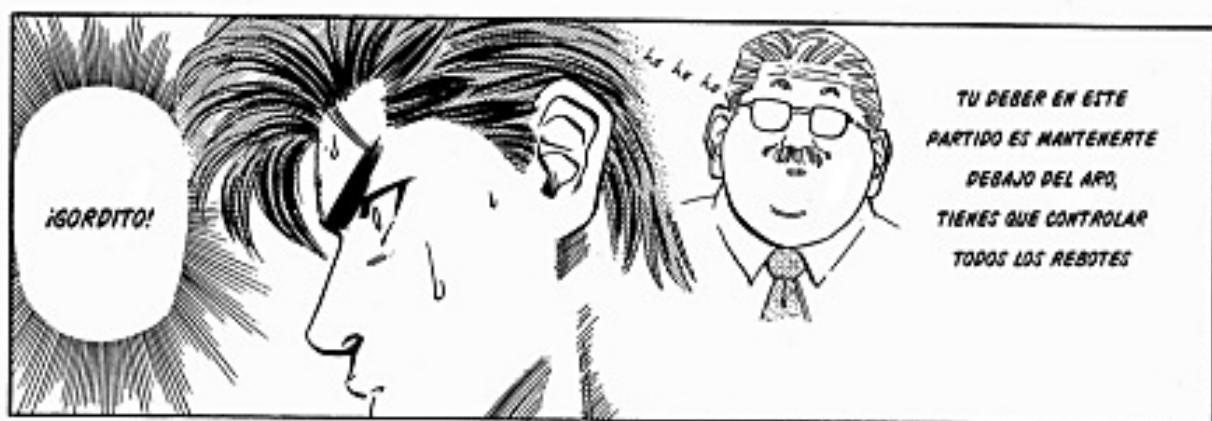

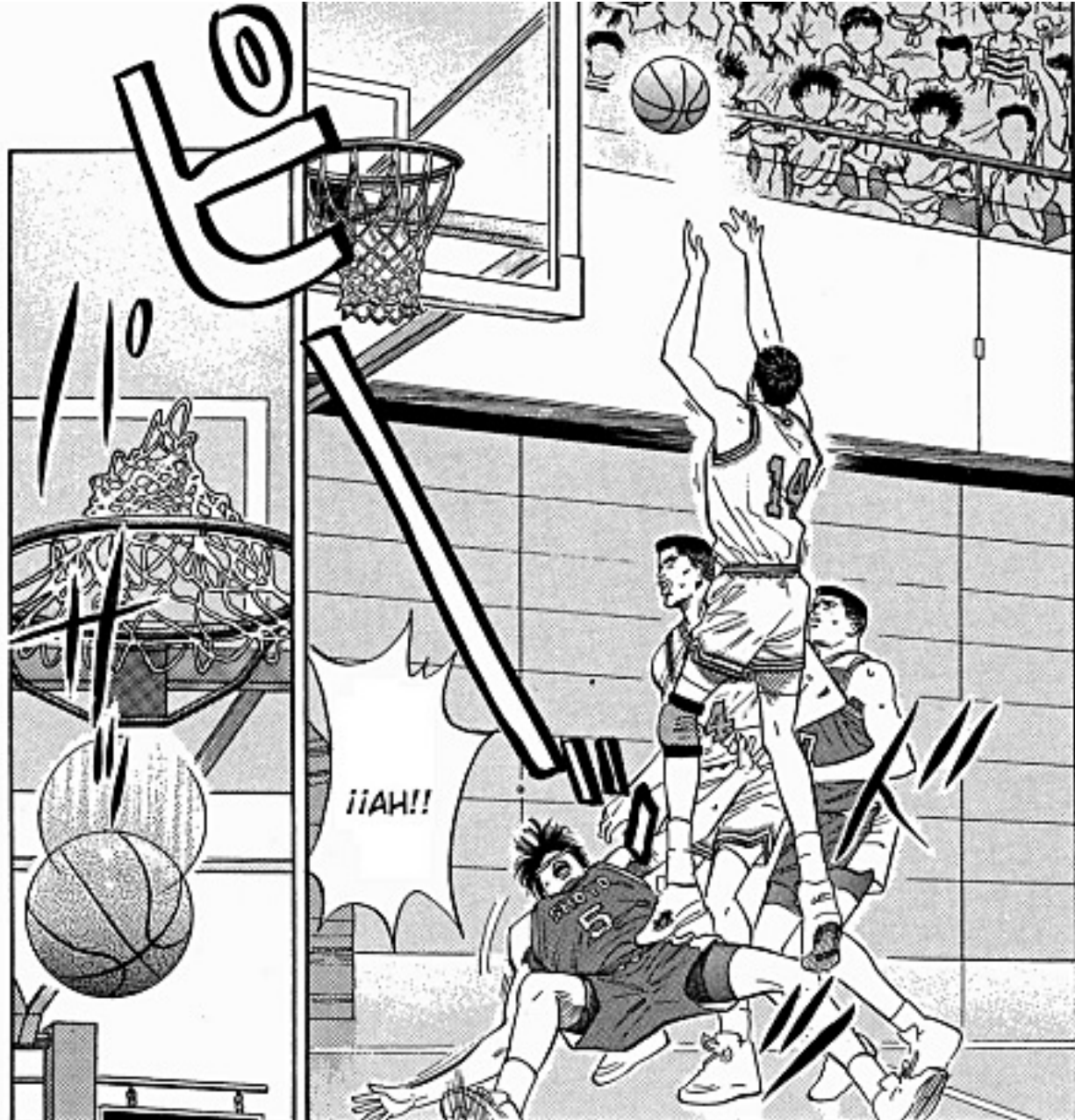

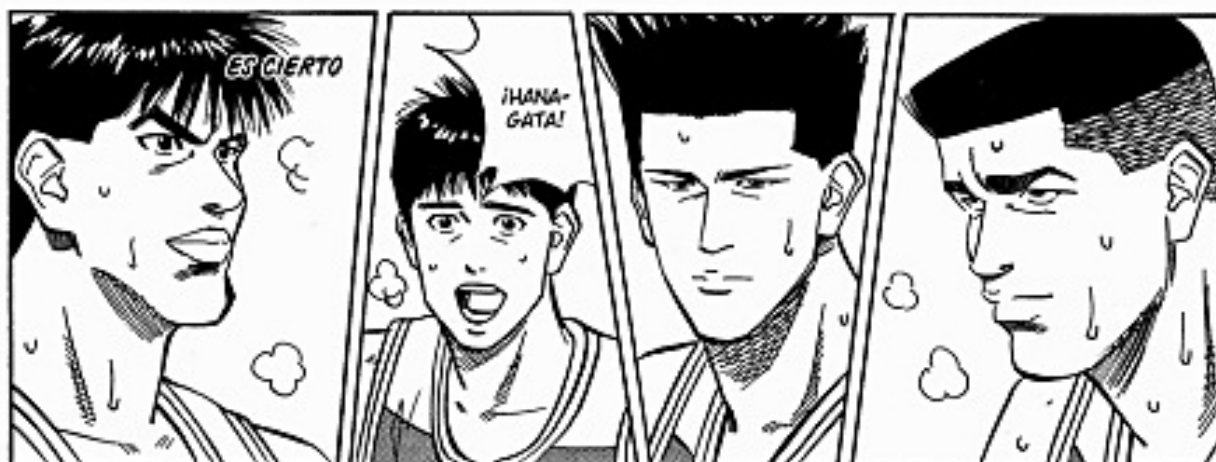

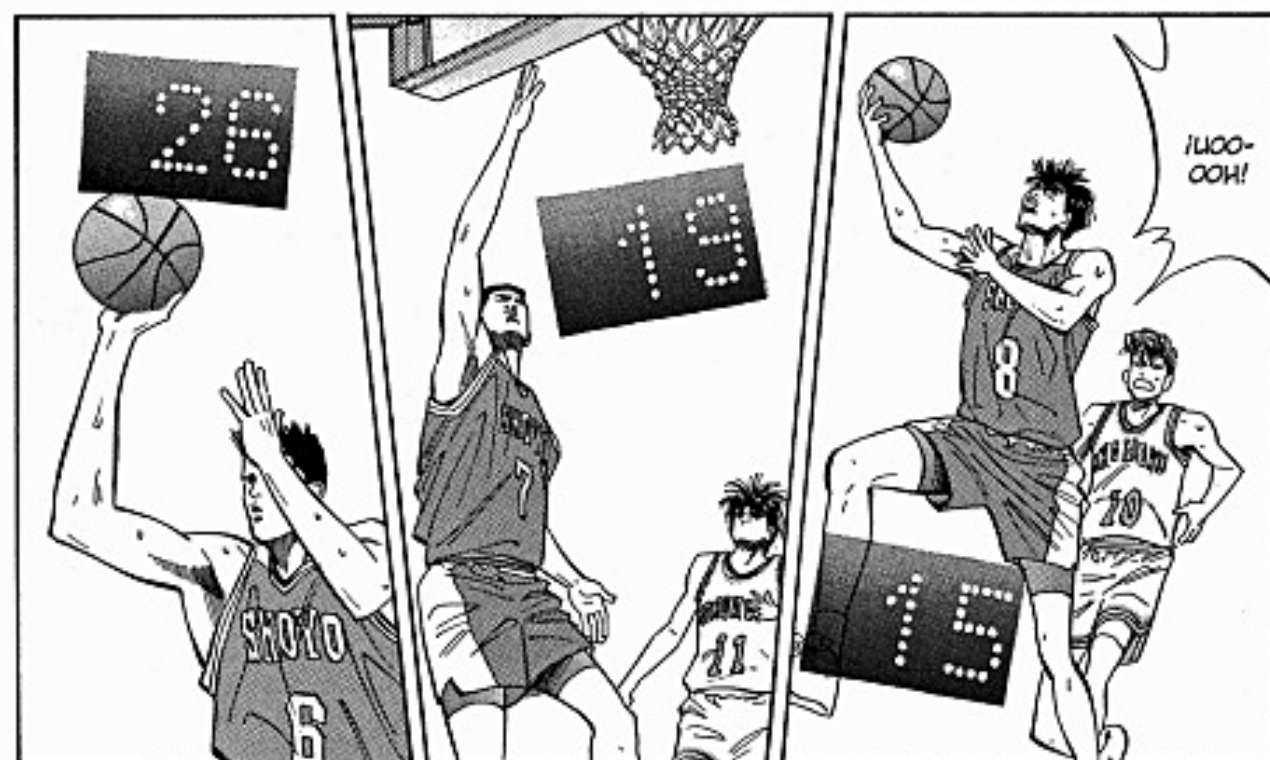





¿P-PORQUE DEBEN SACAR VENTAJA DE QUE FUJIMA AÚN NO HA ENTRADO...?

SHOHOKU DEBE EVITAR QUE ANOTEN A TODA COSTA. ¿SABES POR QUÉ?



PRESTA MUCHA ATENCIÓN, HIKOICHI. ESTA SERÁ LA JUGADA CLAVE



SHOHOKU ESTÁ BAJO MUCHA PRESIÓN, ES ESO LO QUE HACE QUE LOS JUGADORES PIERDAN SU CONCENTRACIÓN Y SE CANSEN MÁS RÁPIDO

ESA ES UNA RAZÓN, OTRA ES EL CANSANCIO



PERO SI DICHA DIFERENCIA ES MÁS GRANDE, SERÁ UN GRAN GOLPE MORAL PARA LOS JUGADORES, Y LA LO MÁS SEGURO ES QUE AUMENTE AÚN MÁS DESPUÉS



CIERTO, ESTÁN MUY AGITADOS ...



EN UNA SITUACIÓN ASÍ SE PONEN TODAS LAS ESPERANZAS EN LA SEGUNDA MITAD...

SI LA DIFERENCIA EN EL MARCADOR NO ES DE MÁS DE 10 PUNTOS, PODRÁN RECUPERARSE





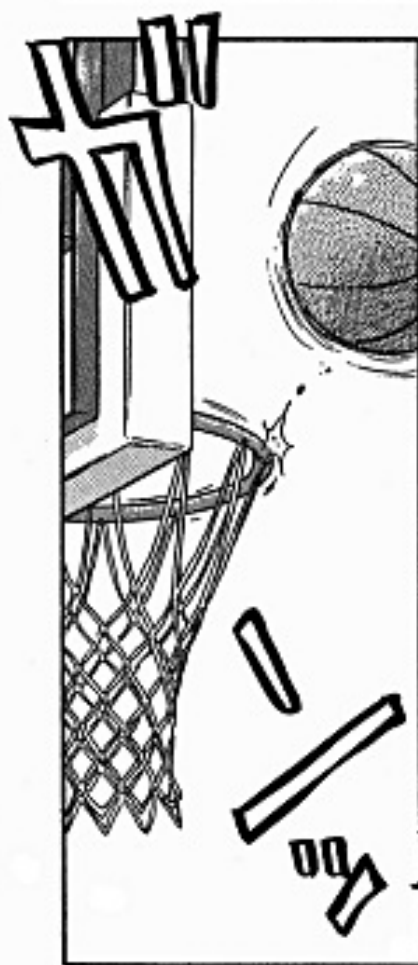



**SLAM
DUNK**

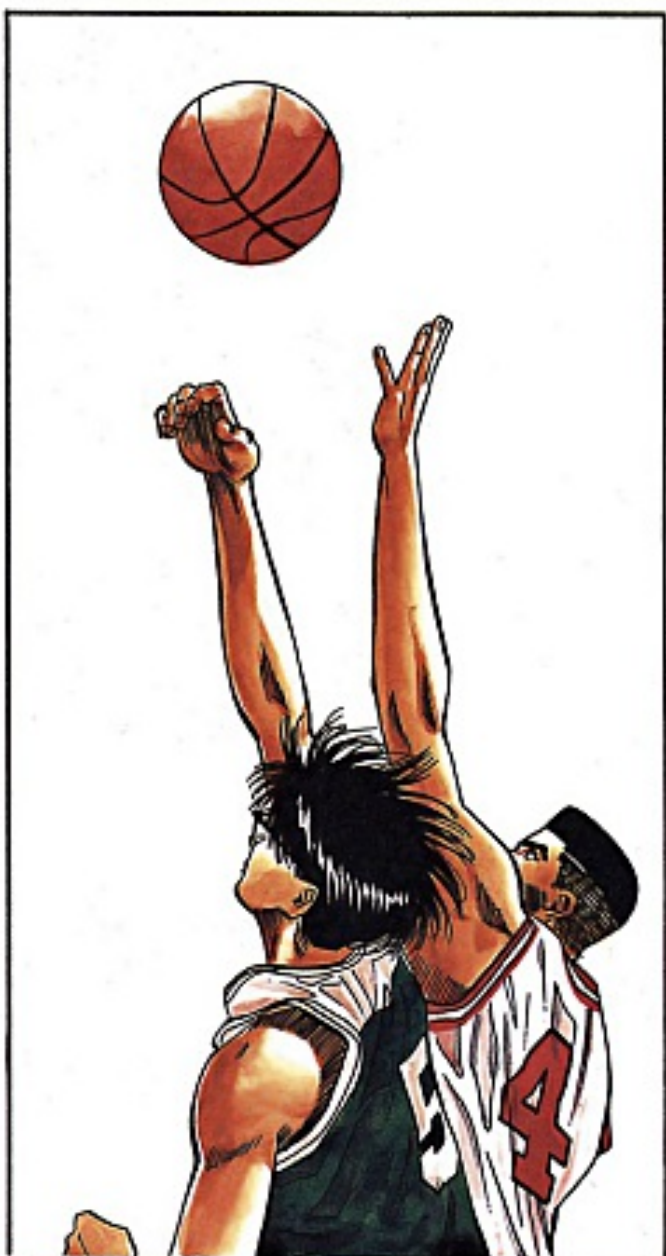
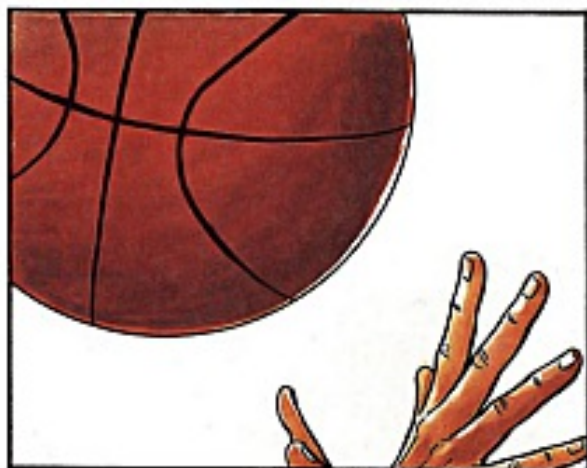

翔陽	前半	休憩	後半	湘北
31	20:00			22



¡VAMOS
A GANAR
ESTE
PARTIDO!

¡MUY
BIEN!
EN LA
SEGUNDA
MITAD...



capítulo 88:
sakurabi, el rey de los rebotes

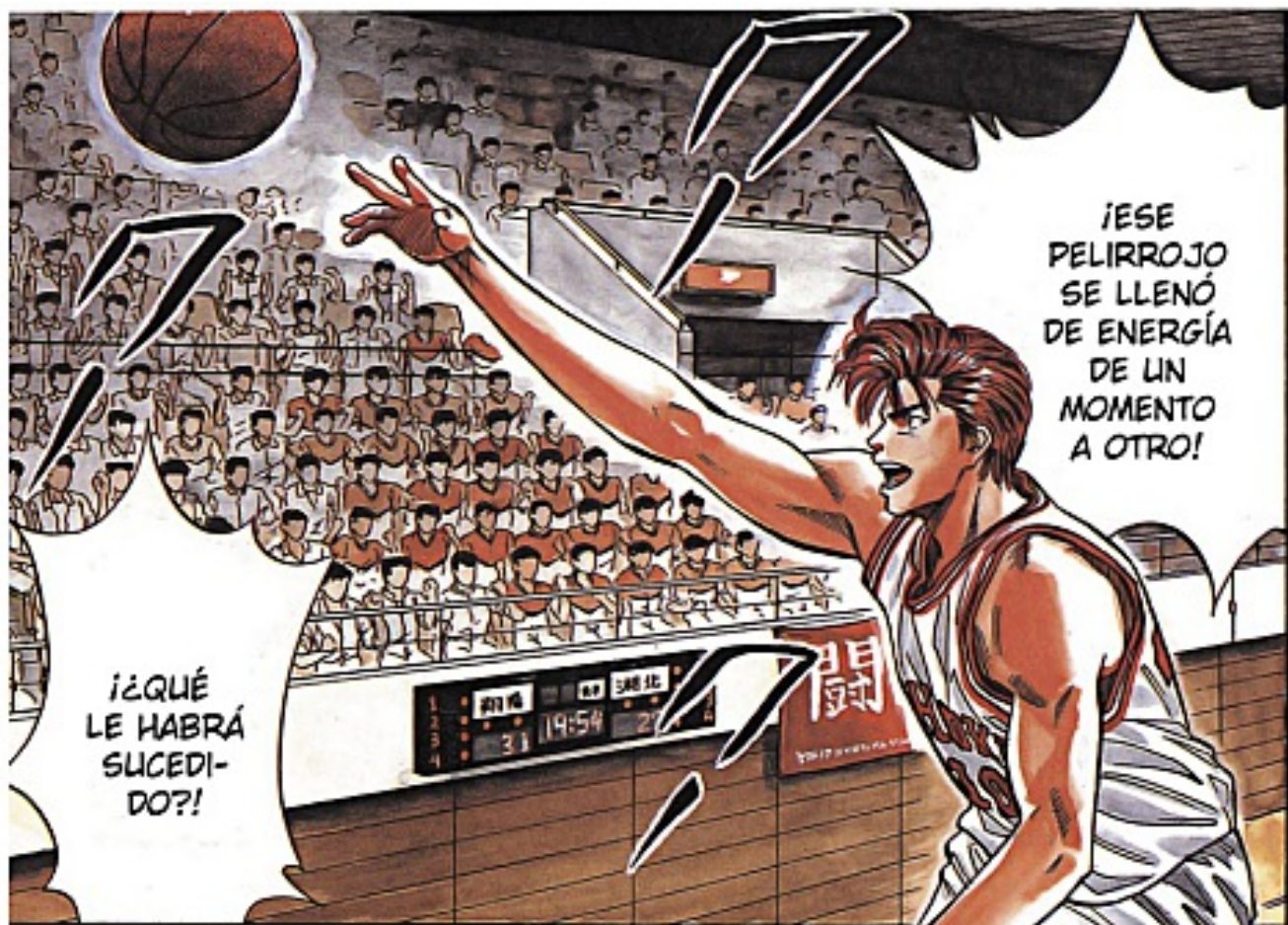

¡ESE
PELIRROJO
SE LLENÓ
DE ENERGÍA
DE UN
MOMENTO
A OTRO!

¿QUÉ
LE HABRÁ
SUCEDI-
DO?!



HARUKO...

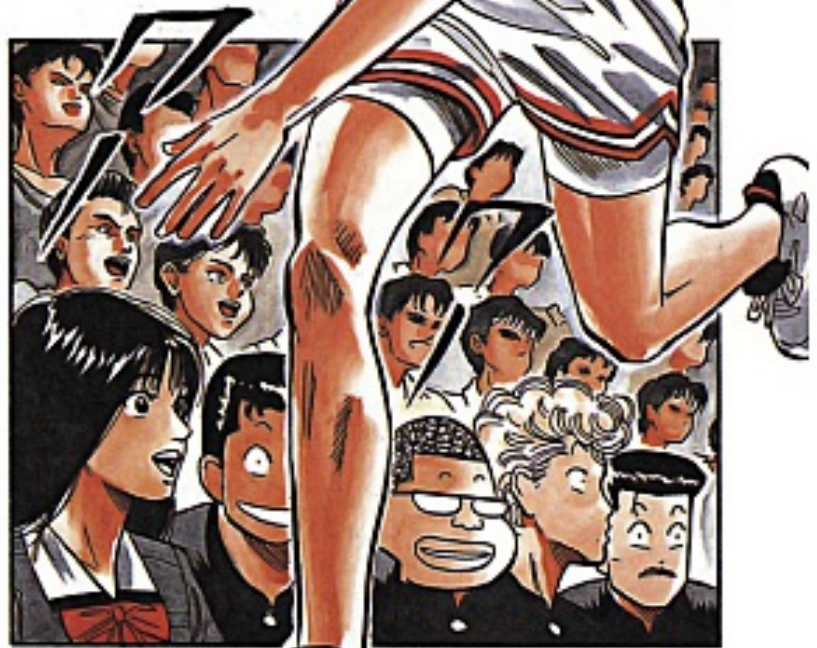

¡INCREDI-
BLE!

更衣室

下足のご案内

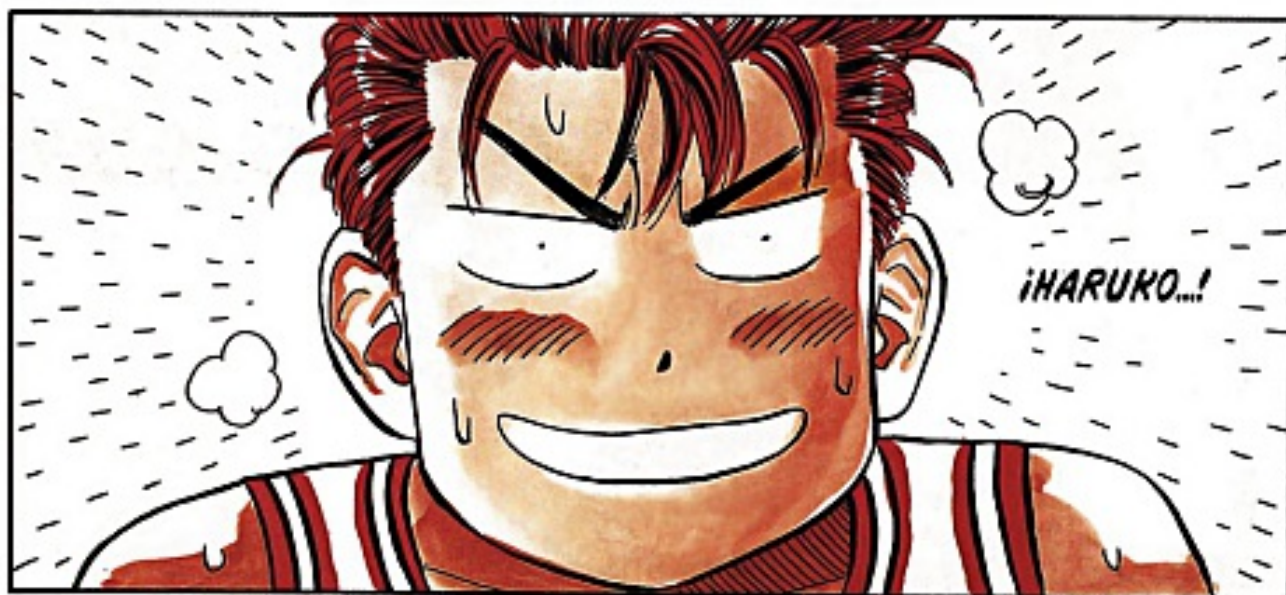
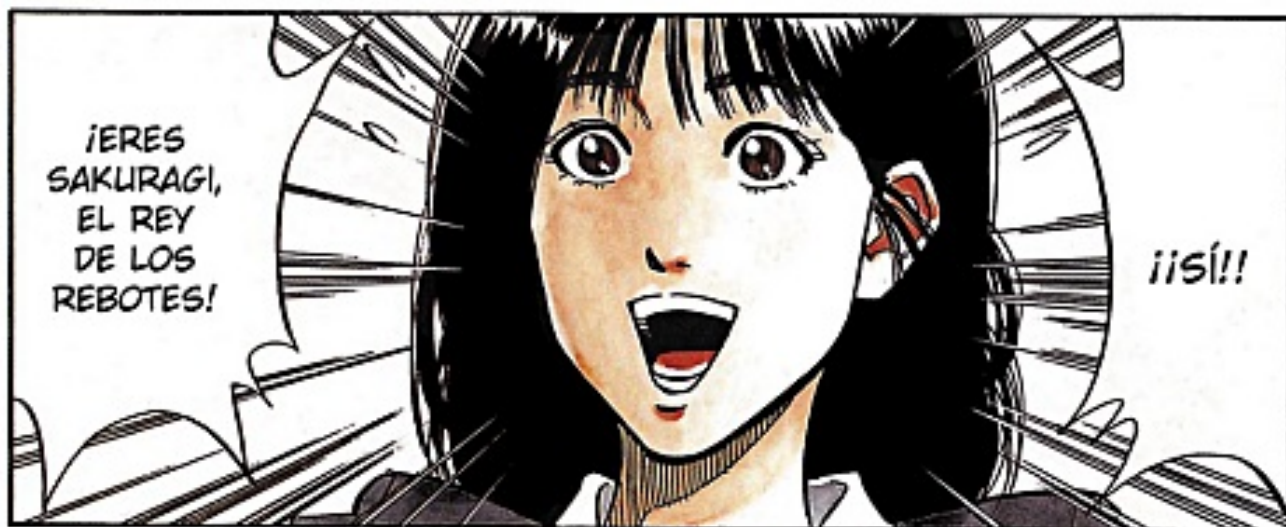



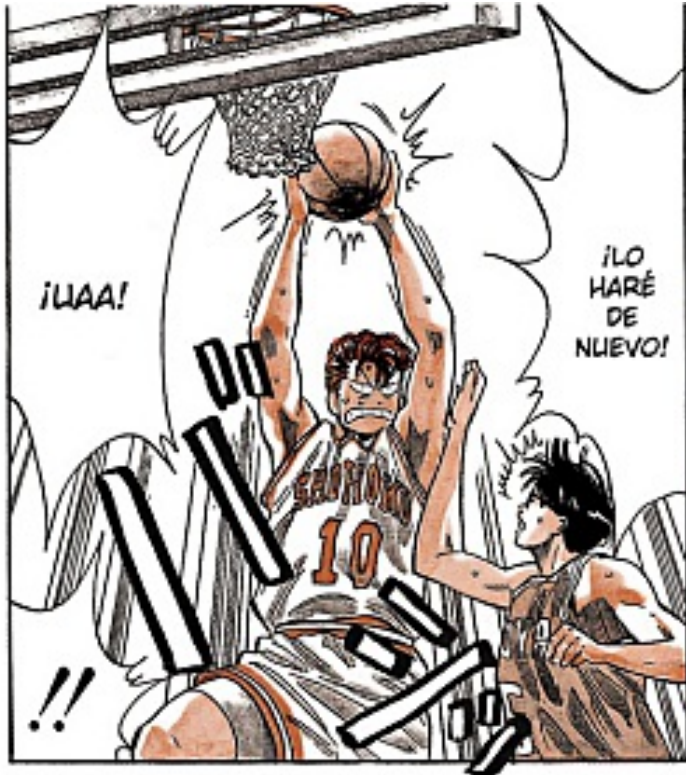

¡UAA!

¡LO HARÉ DE NUEVO!

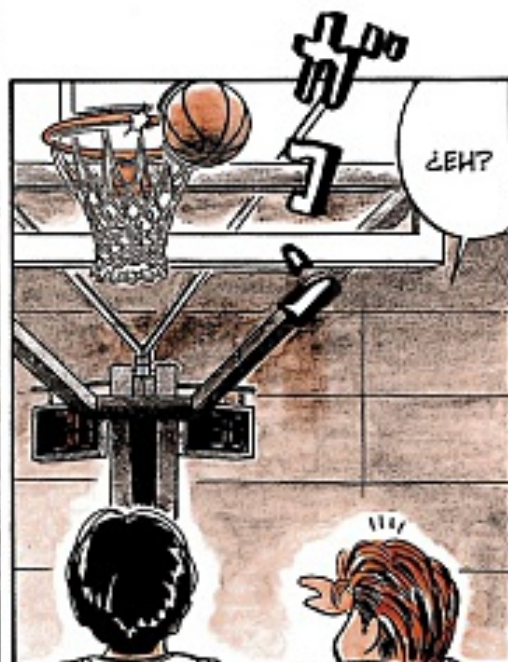

¿EH?

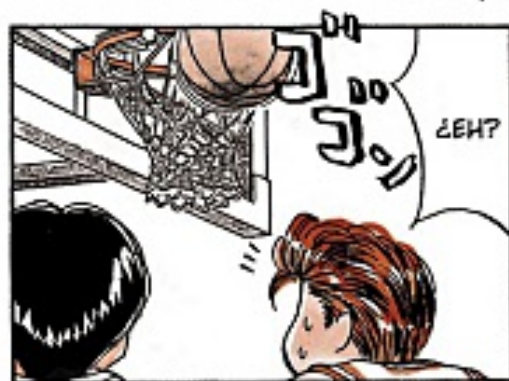

¿EH?



¡LO TENGO!

¡LO TENGO!



¡EL REY DEBAJO DE LA CANASTA!

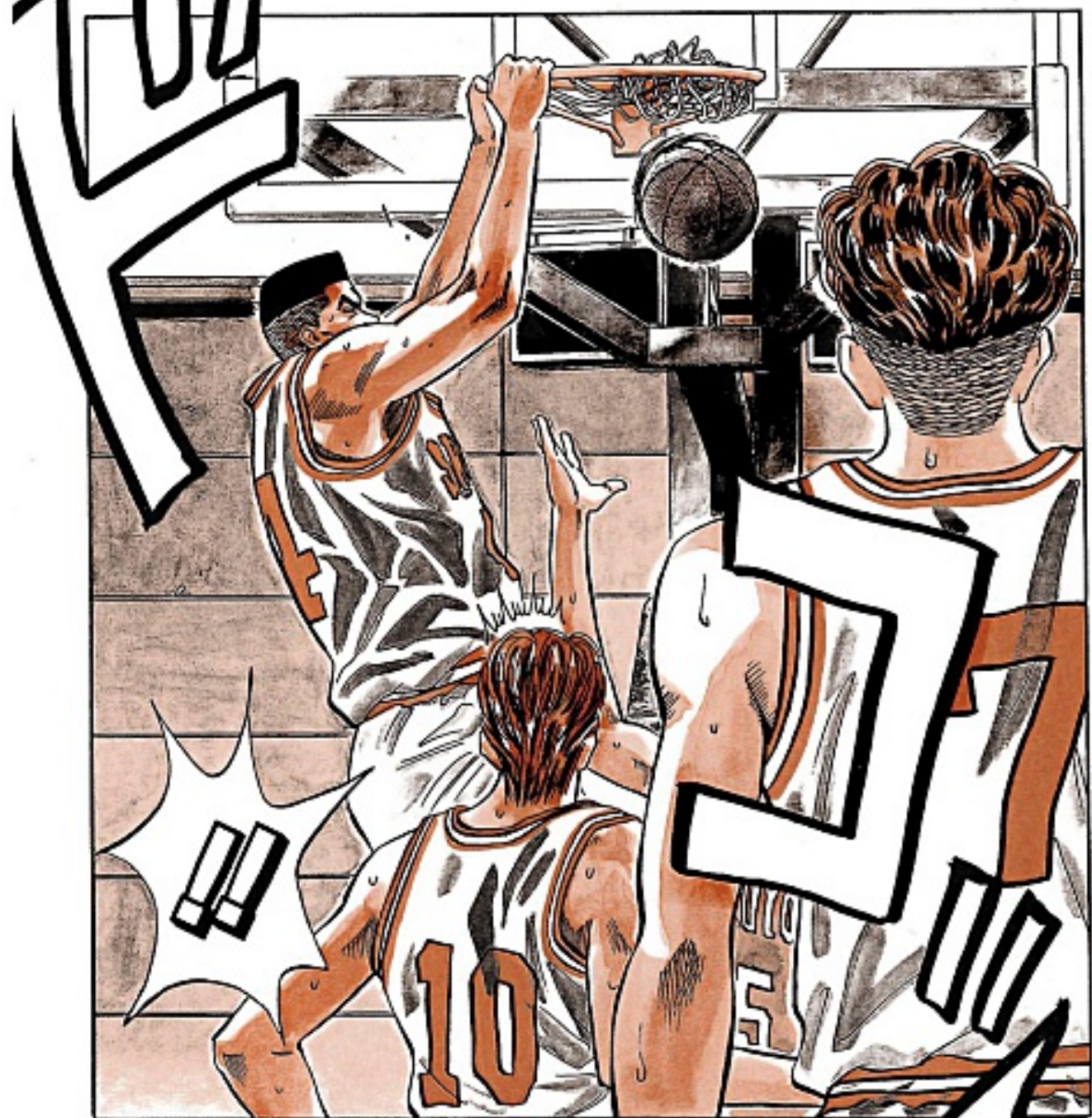



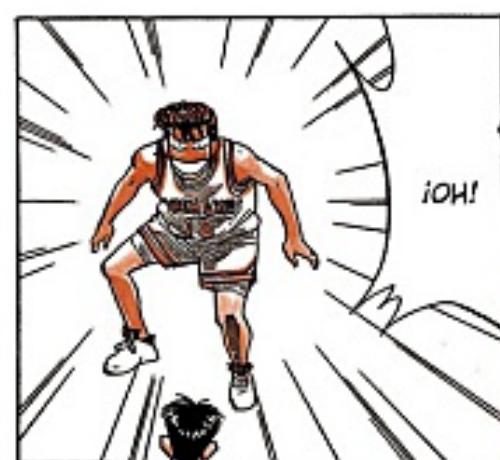
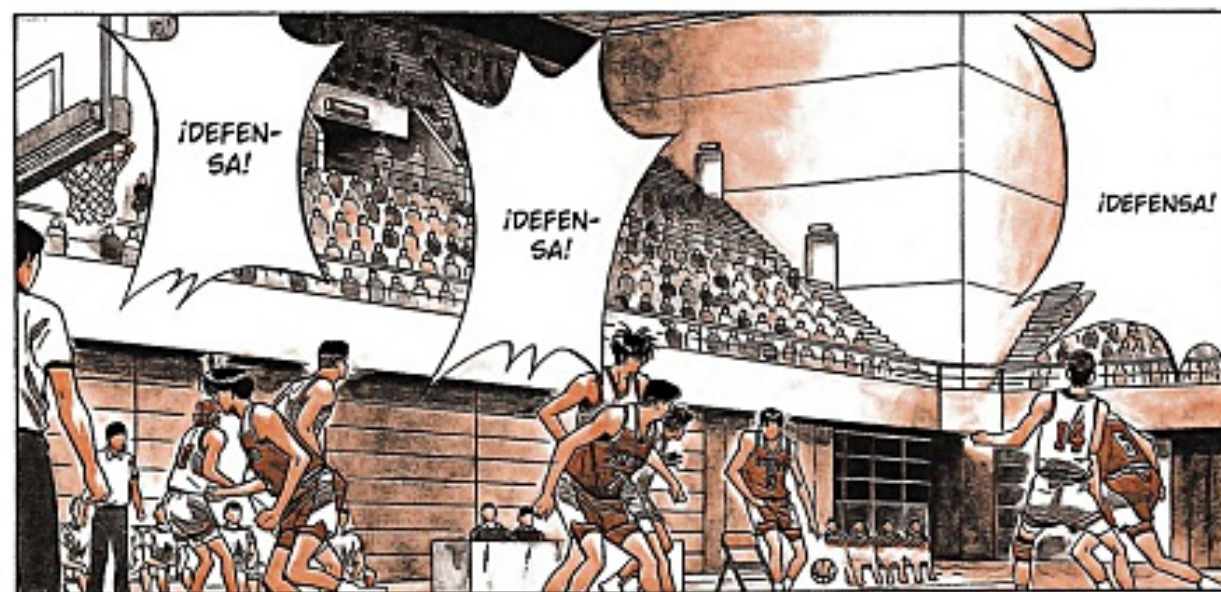



¡HAAA!

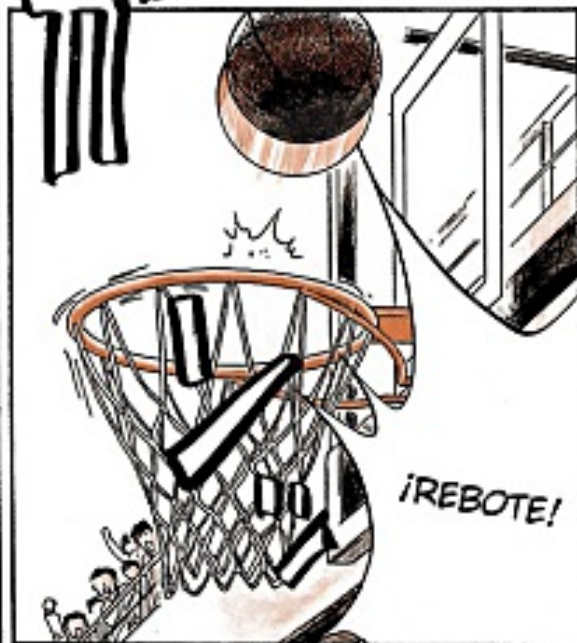

¡REBOTE!

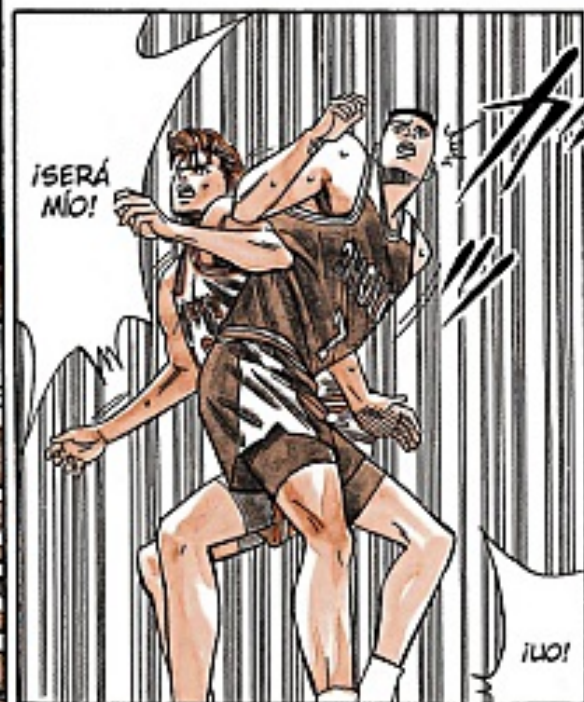

¡SERÁ MÍO!

¡UO!



¡MOCO-SO IDIOTA!

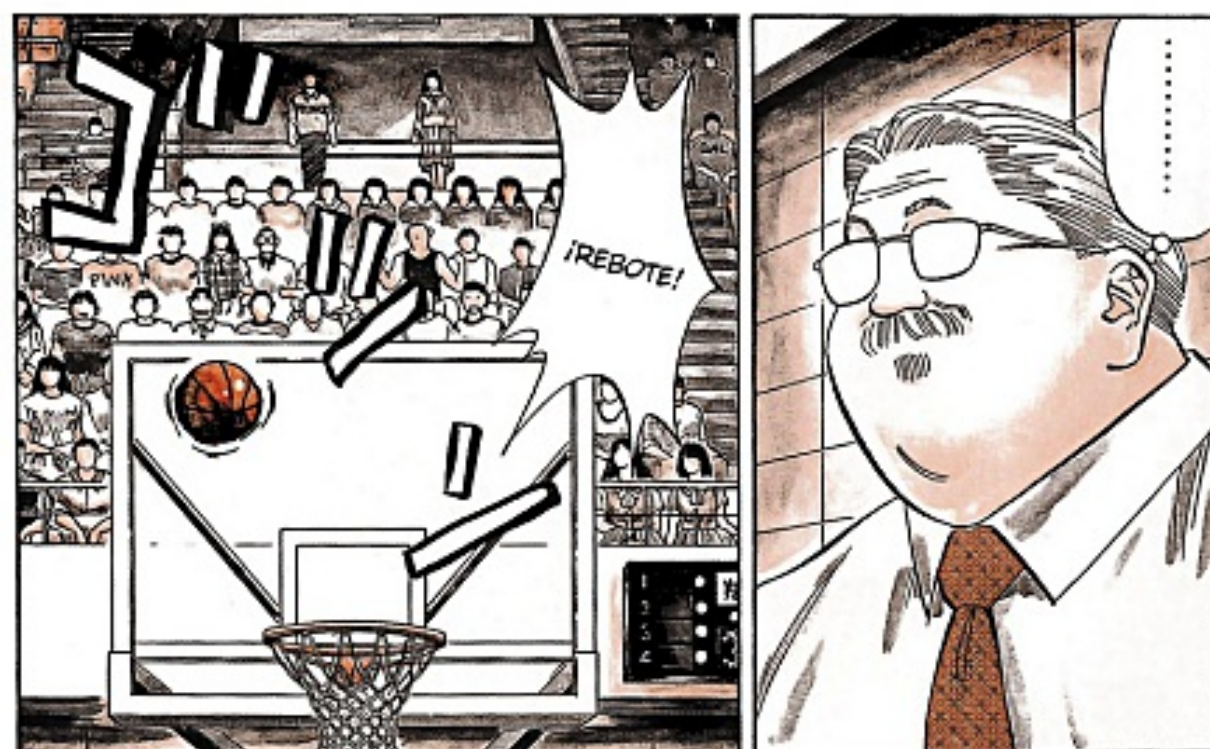
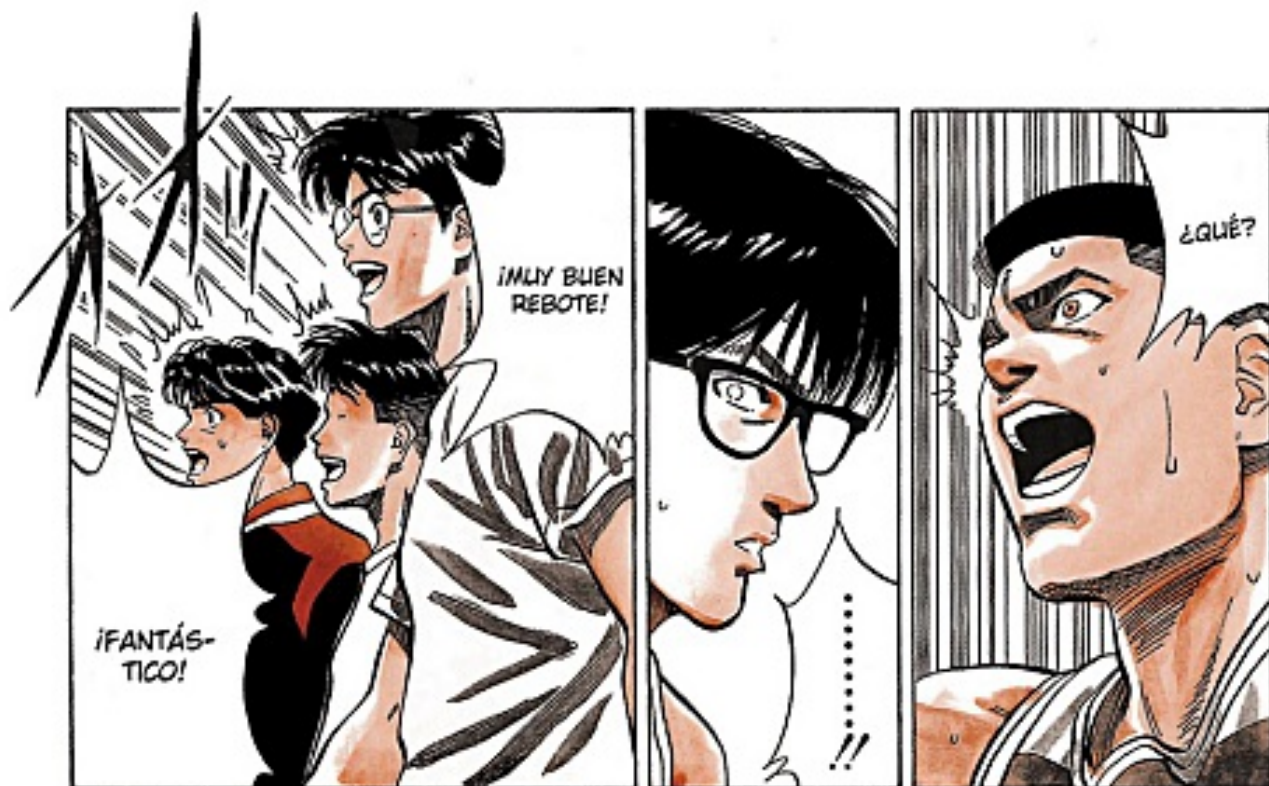

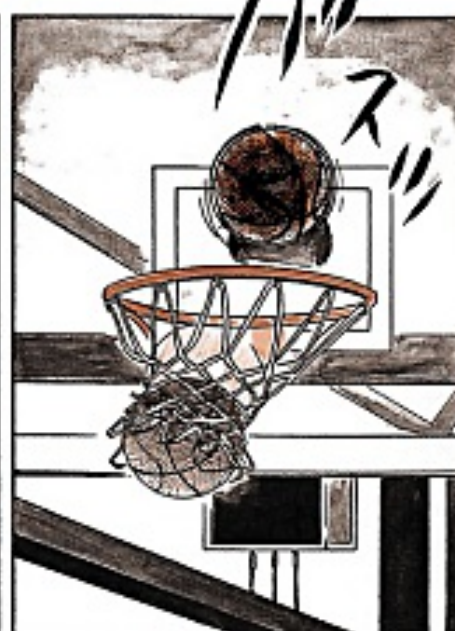
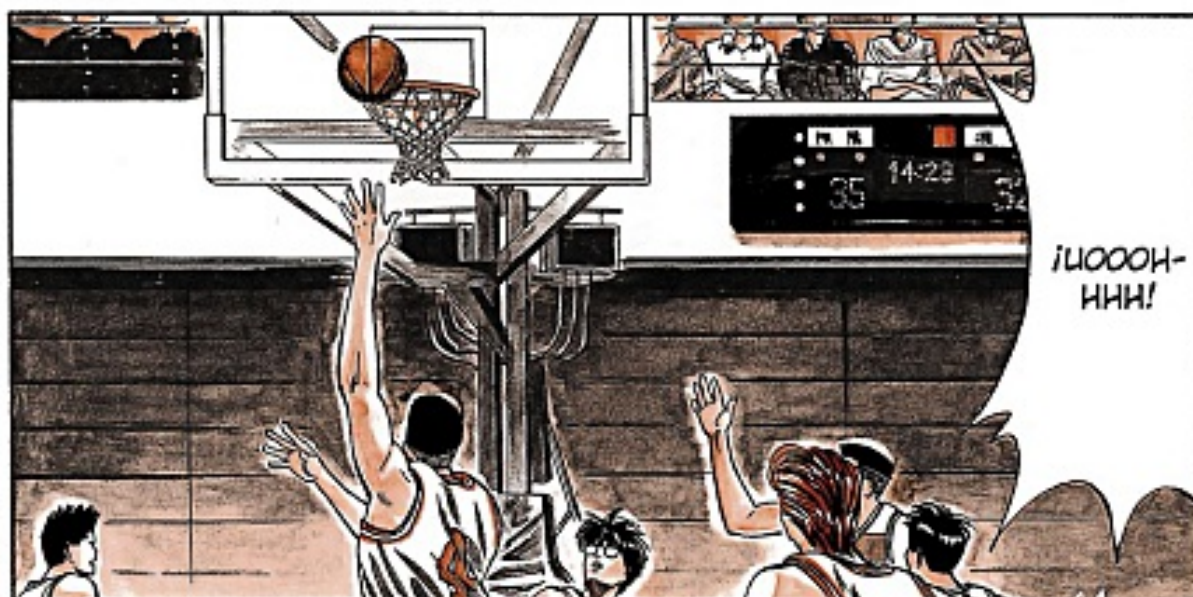
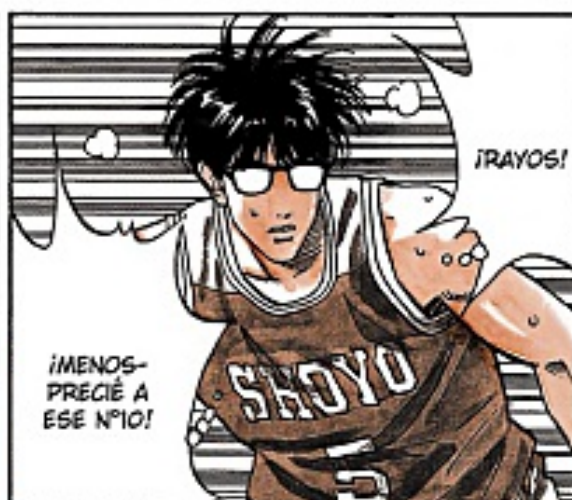



¡LA
SEGUNDA
MITAD HA
SIDO TODA DE
SHOHOKU
...!

¡ABAJO
POR UN
PUNTO!

¡WAH!



PERO JUEGAN
CONTRA SHOU,
EL Nº1 DEL BLOQUE,
NO SERÁ TAN
FÁCIL COMO ESTO

EL RENDIMIENTO
DE SHOHOKU
AUMENTÓ, SIN
LUGAR A DUDAS.

¡acertado, acertado!



¡SAKU-
RAGI!

Y
PENSAR
QUE ESTO
ES TODO
GRACIAS
A UN
JUGADOR



¡EL
PÚBLICO
ESTÁ MUY
ENTUSIAS-
MADO!



¡SHO-
HO-
KU!

¡SHO-
HO-
KU!



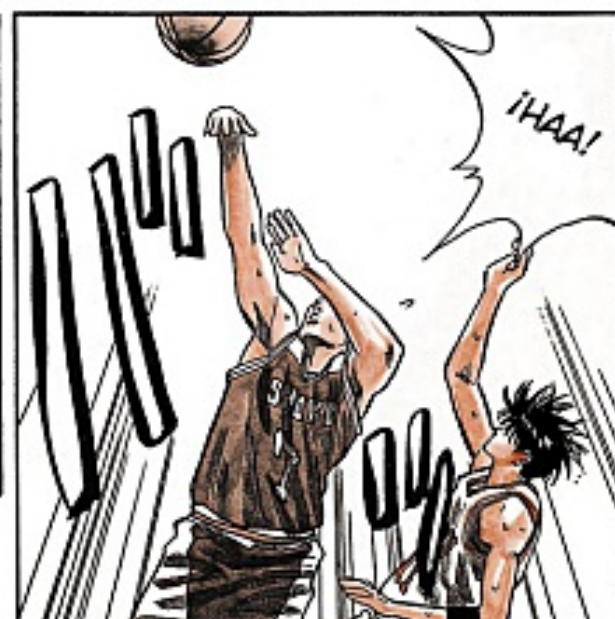
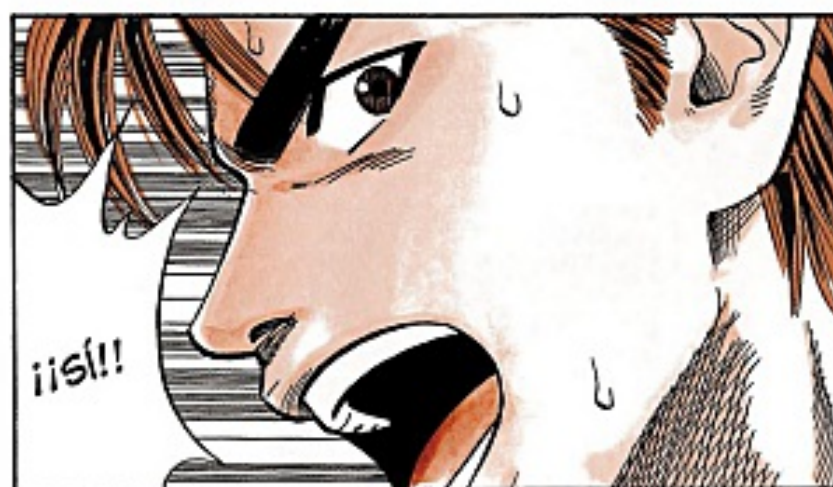





SU
HABILIDAD
INNATA
PARA LOS
REBOTES
EMPIEZA A
APARECER



¡EN
VERDAD
SOY UN
GENIO!

¡JA
JA
JA
JA
JA!

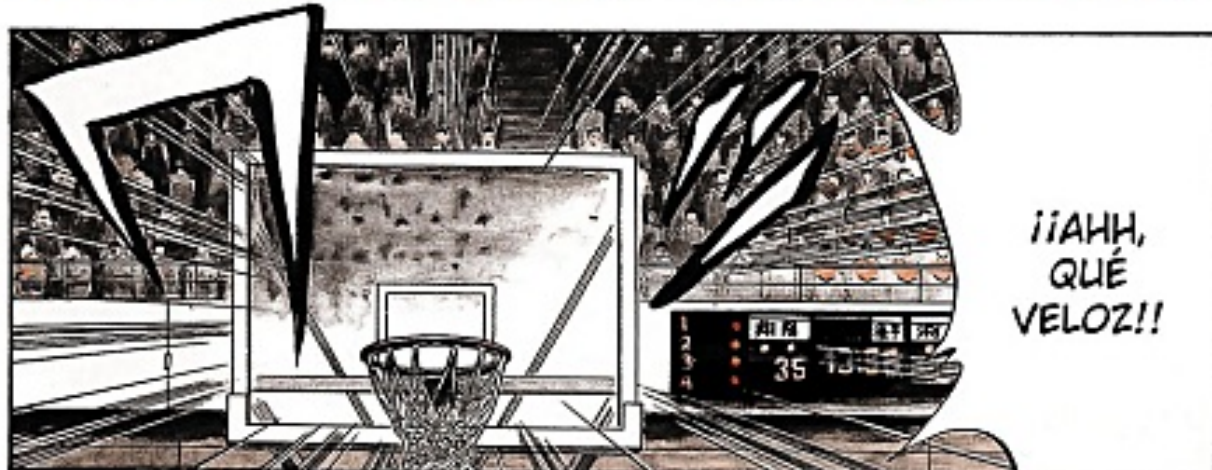
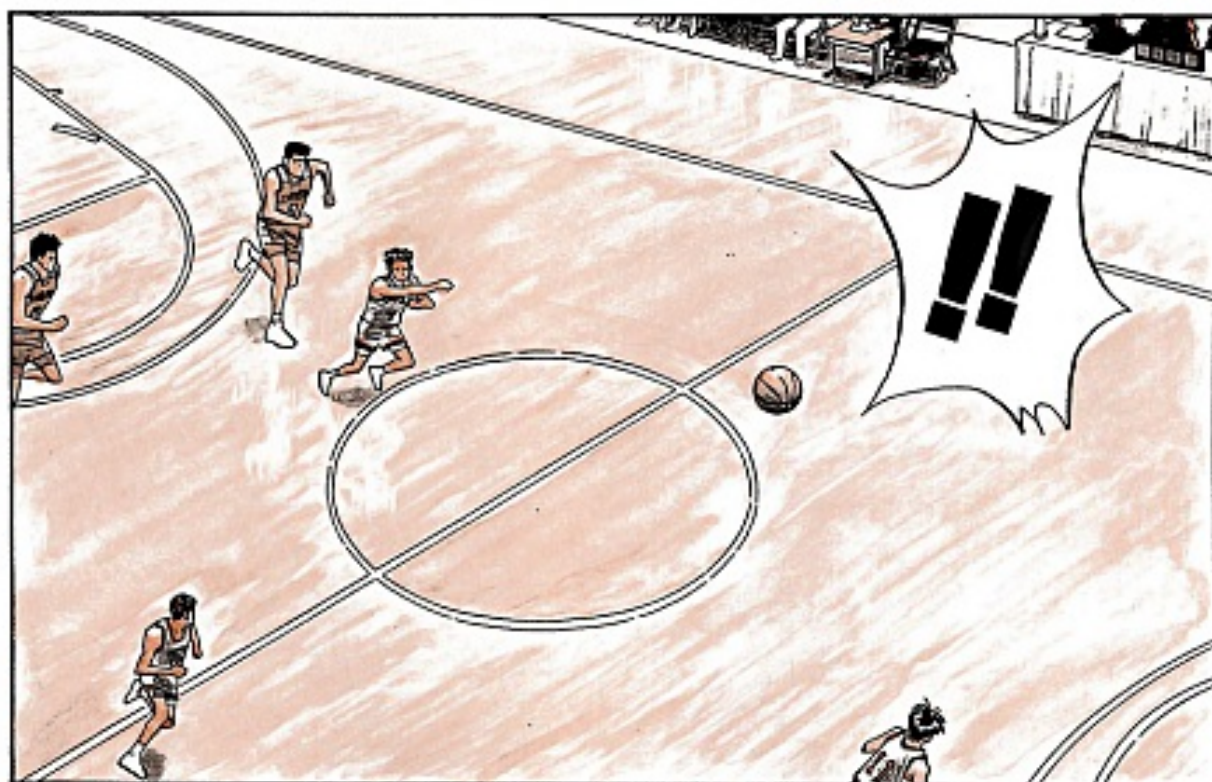
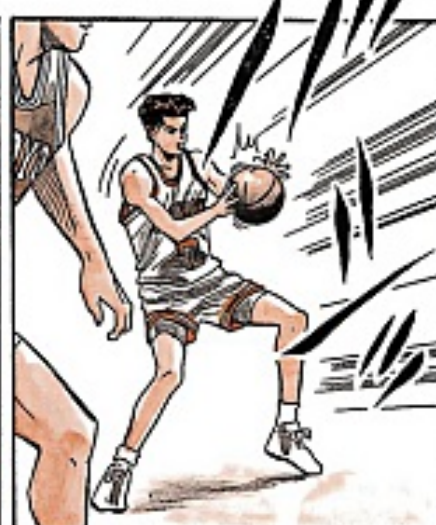

¡AHORA
ESTÁN
ARRIBA
EN EL
MARCA-
DOR!

¡SHOHOKU
ES
INCREÍBLE!

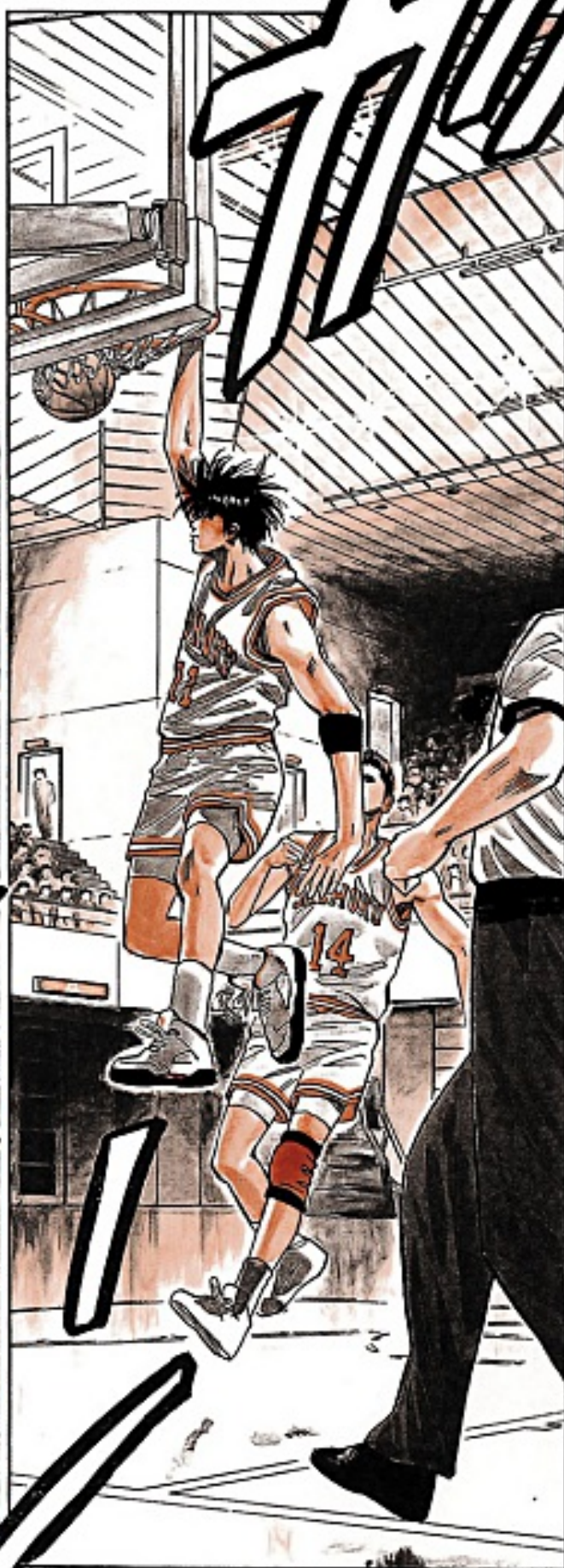

GENIUS·SUBS

visítanos en:

<http://geniussubs.co.cc>

**CORRECCIÓN Y
MONTAJE
MANAKA**

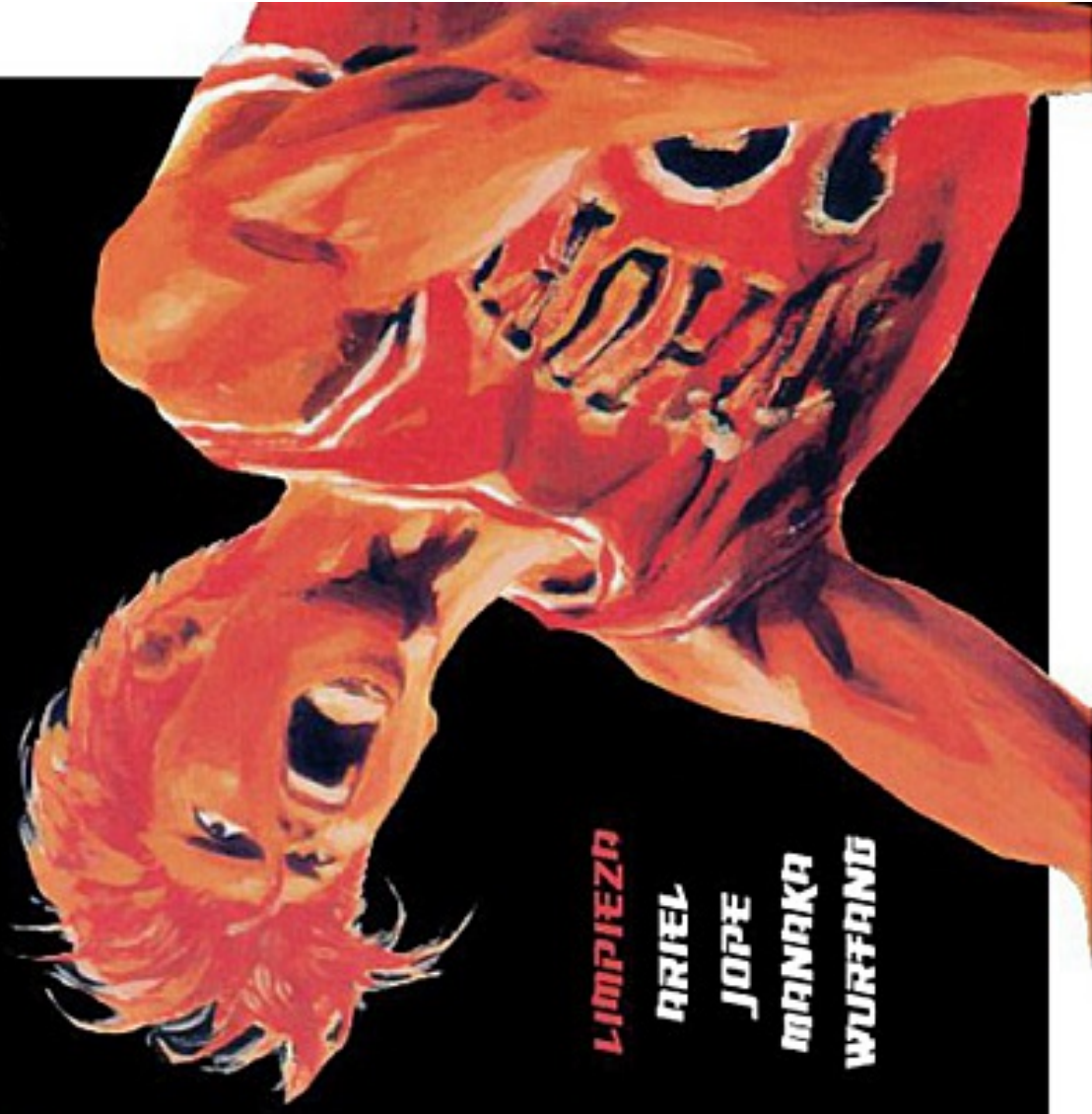

**PRODUCCIÓN
KAGEROYAMI
RED-HELLING
MANAKA**

**LIMPIEZA
ARIEL
JOPE
MANAKA
WURFANG**

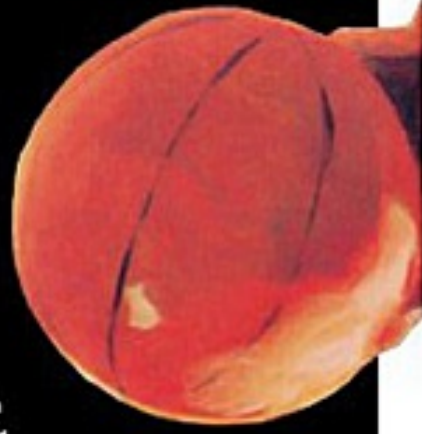

**SLAM
DUNK**



capítulo 89: el n.º 4 del instituto shoyo











¡ADEMÁS DE NOSOTROS, NADIE LE HABÍA DADO TANTOS PROBLEMAS A SHOYO!

¡JE, SHOHOKU ES UN Oponente DURO!



¡ESTE AÑO, EL EQUIPO DE KAINAN ES MÁS FUERTE QUE NUNCA!

¡PERO QUIEN GANE ESTE JUEGO NO CAMBIA QUIÉN SERÁ CAMPEÓN!



¡REPORTE DE ÚLTIMO MINUTO!



¡PORQUE SE LES HA UNIDO UN NOVATO DE ORO!

¡JAJA
JAJA
JAJA
JAJA!



ISHOHOKU
HA VUELTO
DE LA
MUERTE!



¿QUÉ?

!



¿Ryōdan?
Me confundí de
restaurio.

¿EH?





¡EL
RELUCIENTE
NUEVO
TITULAR DE
KAINAN!

¡YO SOY EL
NOVATO
Nº1 DE TODA
KANAGAWA,
NOBUNAGA
KIYOTA!



JAJAJA

ES LA
PERSONA MÁS
DESCONSIDERADA
QUE CONOZCO...
...DESPUÉS DE
SAKURAGI

GRR

¡INOCOSO
ENGREÍDO!

ENOBUN-
NAGA
KIYOTA?



ASÍ
QUE
...





¡¡sí!!



¡CAMBIO DE
JUGADOR,
SHOYO

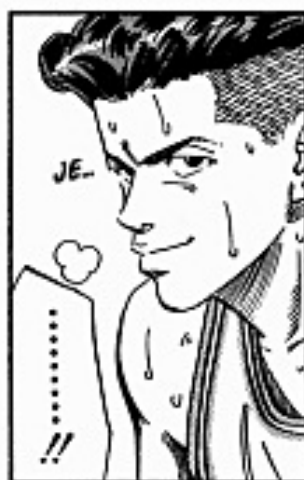

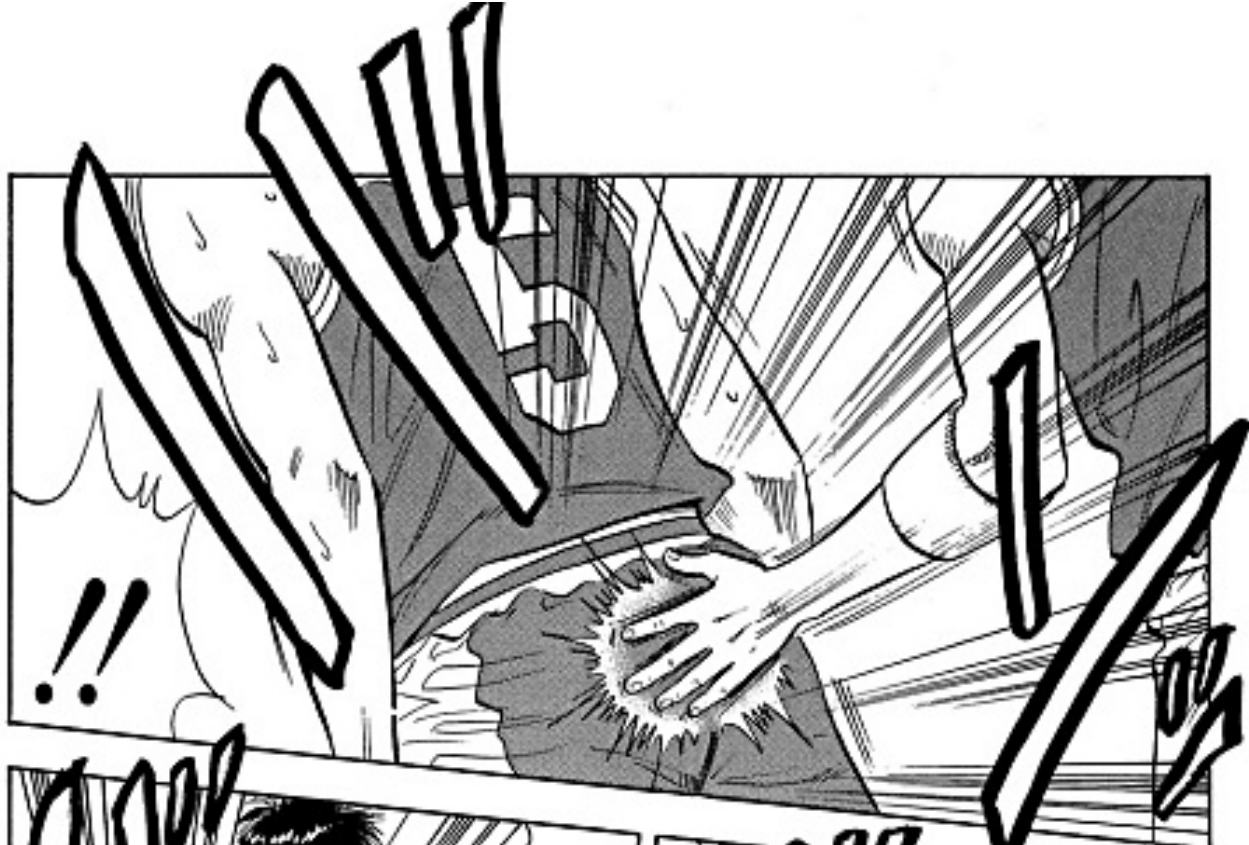





¡¡¡!!

¡VAMOS!



PERO CUANDO PISA LA CANCHA TIRA TODA ESA CALMA EN UN INSTANTE...



FUJIMA, EL JUGADOR ENTRENADOR, CUANDO ESTÁ EN EL BANCO ...

DEBE OBSERVAR EL JUEGO Y ESTAR MUY CALMADO...



¡SU MIRADA CAMBIÓ TOTALMENTE!

¡CUANDO ESTABA EN EL BANCO, FUJIMA SE VEÍA MUY TRANQUILO, PERO EN EL JUEGO ES OTRO!

¡HASTA LOS OTROS 4 SE VEN DIFERENTES!





¡FUJIMA!

¡FANTÁSTICO!

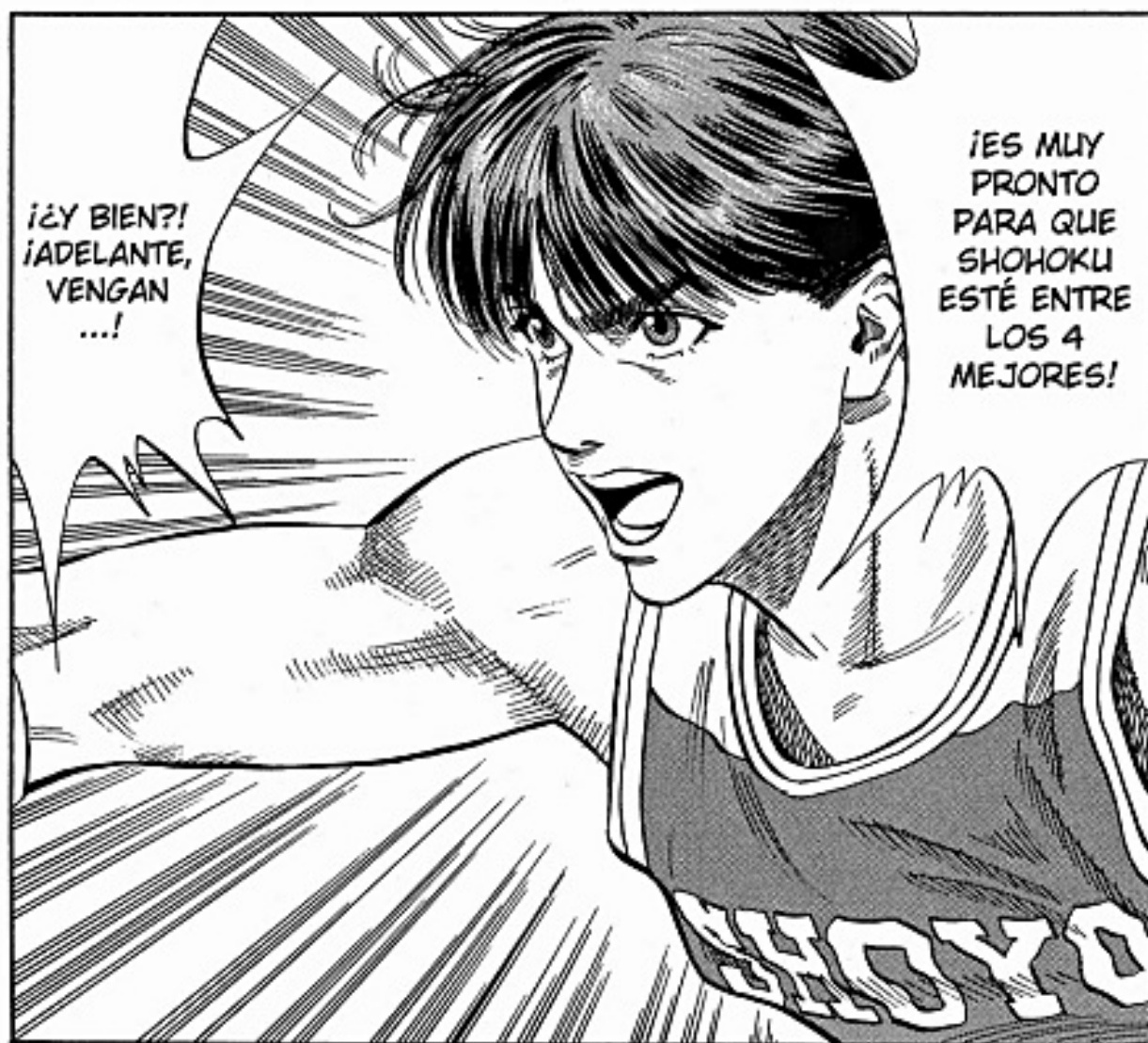

¡¿Y BIEN?!
¡ADELANTE,
VENGAN
...!

¡ES MUY
PRONTO
PARA QUE
SHOHOKU
ESTÉ ENTRE
LOS 4
MEJORES!



Genius-Subs

visítanos en:

<http://geniussubs.co.cc>

Corrección y
montaje
Manaka

Limpieza:
ariel
jope
manaka
wurtang

Traducción:
Kageroyami
Red-Hellin@
Manaka

**SLAM
DUNK**

capítulo 98: el shoyo
dirigido por
Aiyama







ISAKU-
RAGI!

IAH,
HANA-
MICH!



ILO
TEN-
GO!



IEL
GENIO
SAKU-
RAGI!





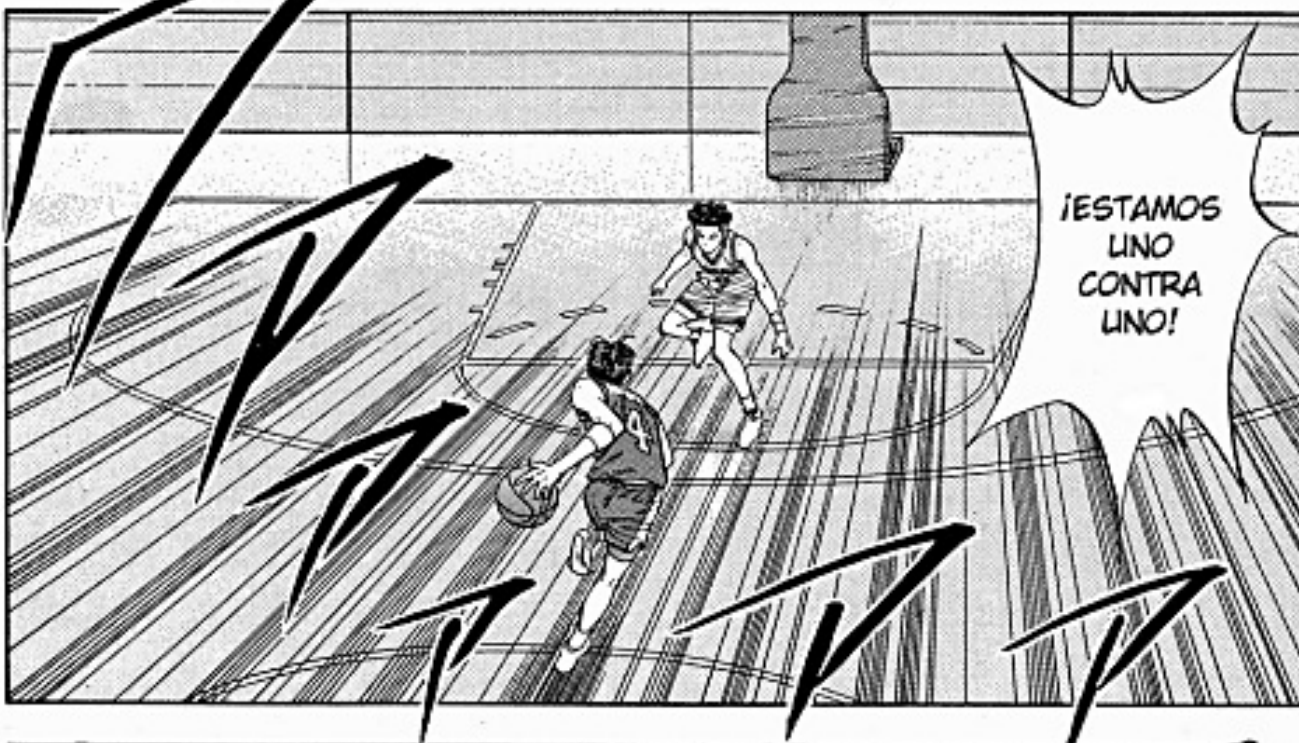



¡MUY BIEN!

¡AUNQUE HAYA UNA DIFERENCIA DE 10 CM, RYOTA DEBERÍA PODER PARARLO!

¡FUJIMA MIDE 1,75 Y RYOTA 1,68!



¿QUÉ?!







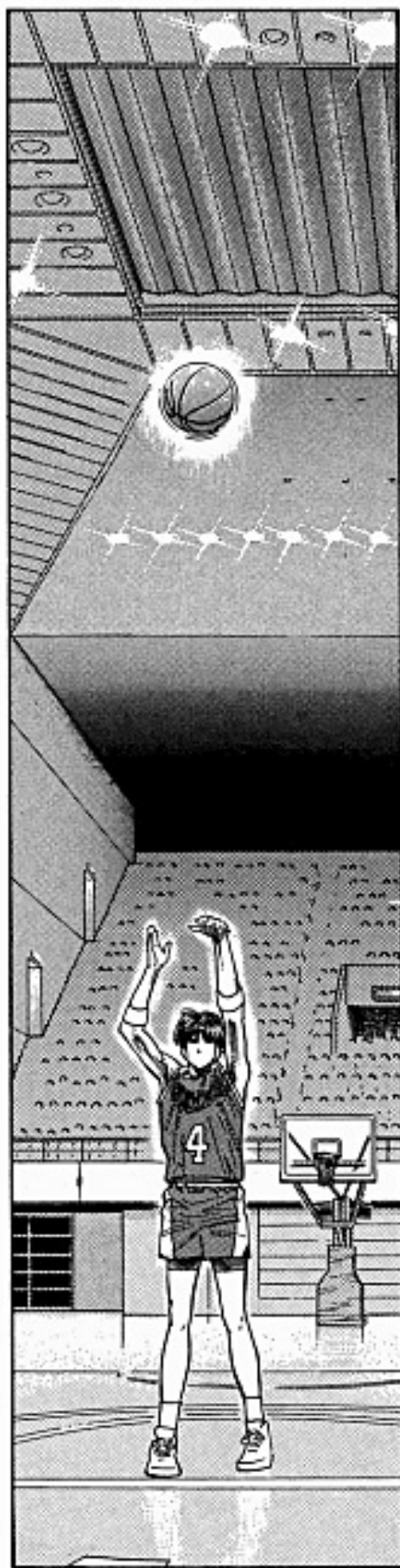

<<Falta intencional>>

Quando el arbitro cree que un jugador ha cometido una falta totalmente a propósito, cobra falta intencional, el jugador víctima de la falta obtiene un tiro libre extra y su equipo tiene el balón de vuelta al reanudar el juego

Las Clases de Basketball del Dr.T



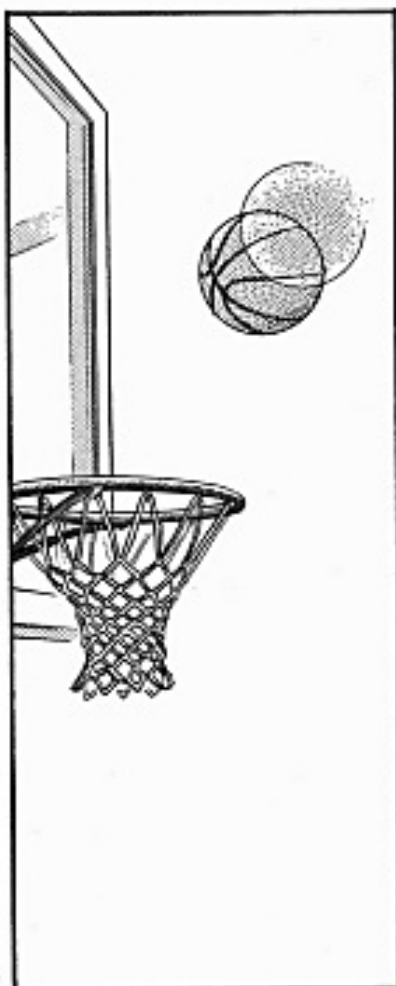

Nota de traducción: La consecuencia de la falta intencional... molesta, ¿no?



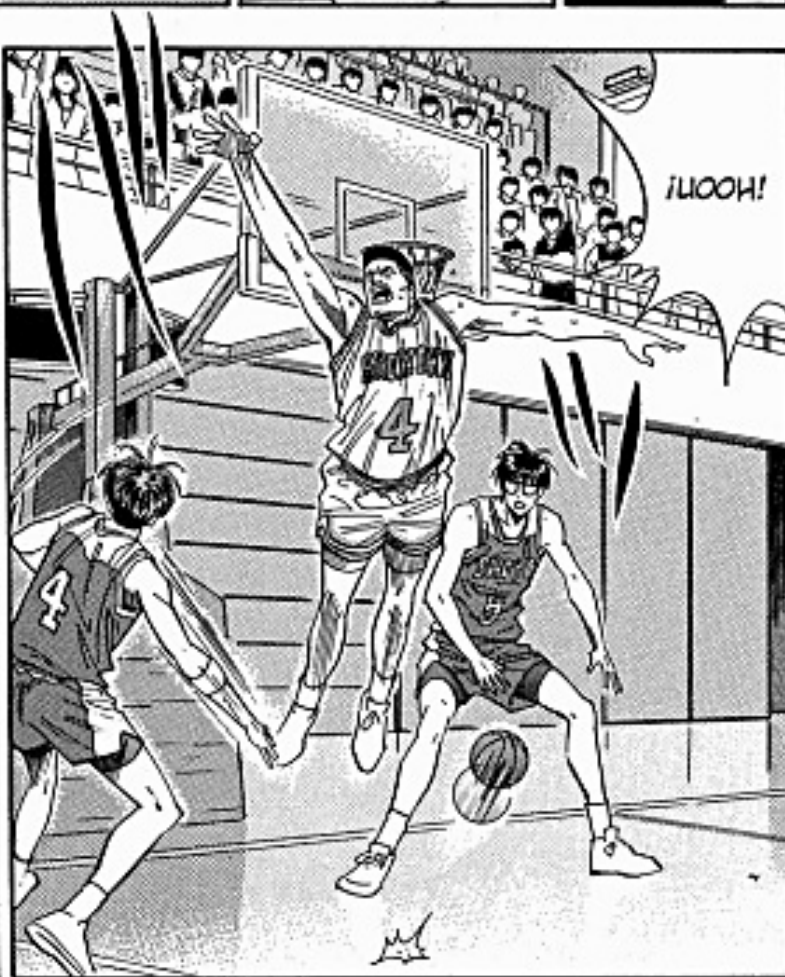

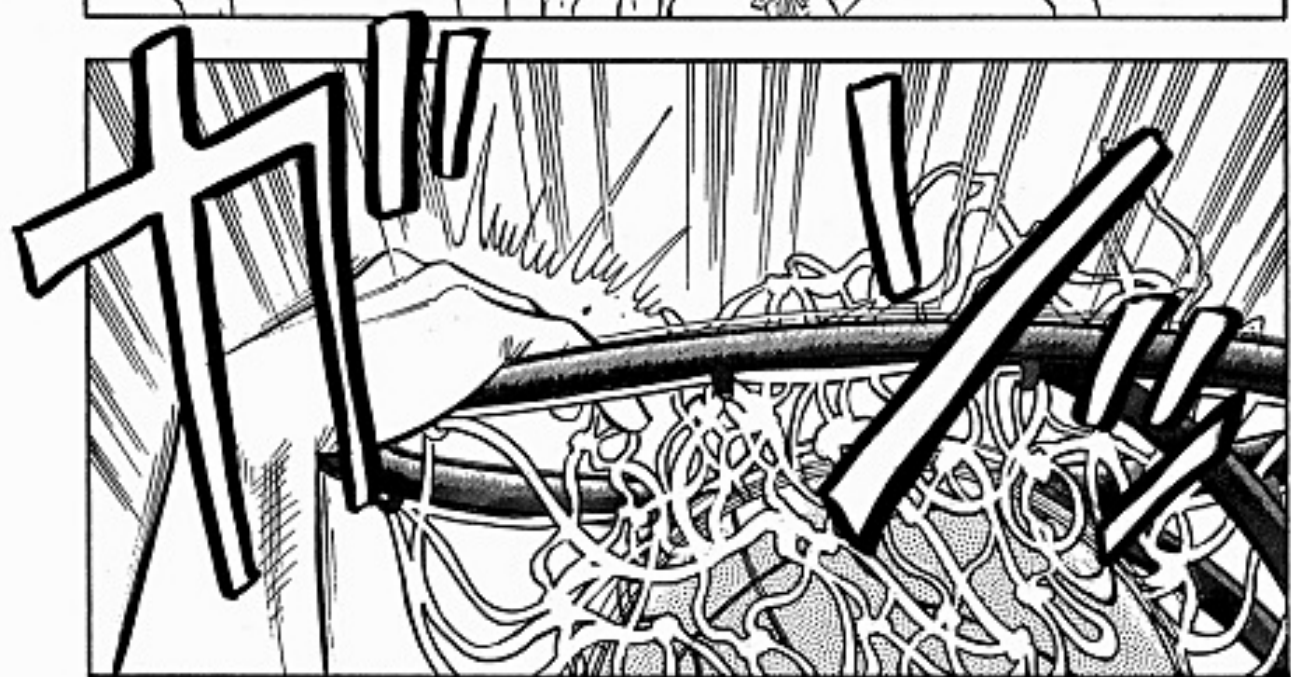



¡TIEMPO
FUERA,
SHOHOKU!



¡MAL-
DITA
SEA!



¡MUY
BIEN!







¡CLARO QUE SÍ!



.....



¡¡ NOSOTROS SOMOS UN EQUIPO IGUAL DE FUERTE!!



PERFECTO ...

SLAM **9** **DUNK**
by INOUE TAKEHIKO Vol.



¡TAMPOCO
IMPORTA
QUIÉN ES
NUESTRO
OPONENTE,
DEBEMOS
VENCERLO!

¡EL HECHO DE
QUE EL AÑO
PASADO HAYAN
TENIDO UN
PROMEDIO
TAN BUENO
NO IMPORTA!



¡DEBEMOS
SEGUIR
ATACANDO,
VAMOS A
MOSTRAR
QUIÉN ES
SHOYO!

¡NI SIQUIERA
PIENSEN EN
SÓLO TRATAR
DE MANTENER
LA VENTAJA!

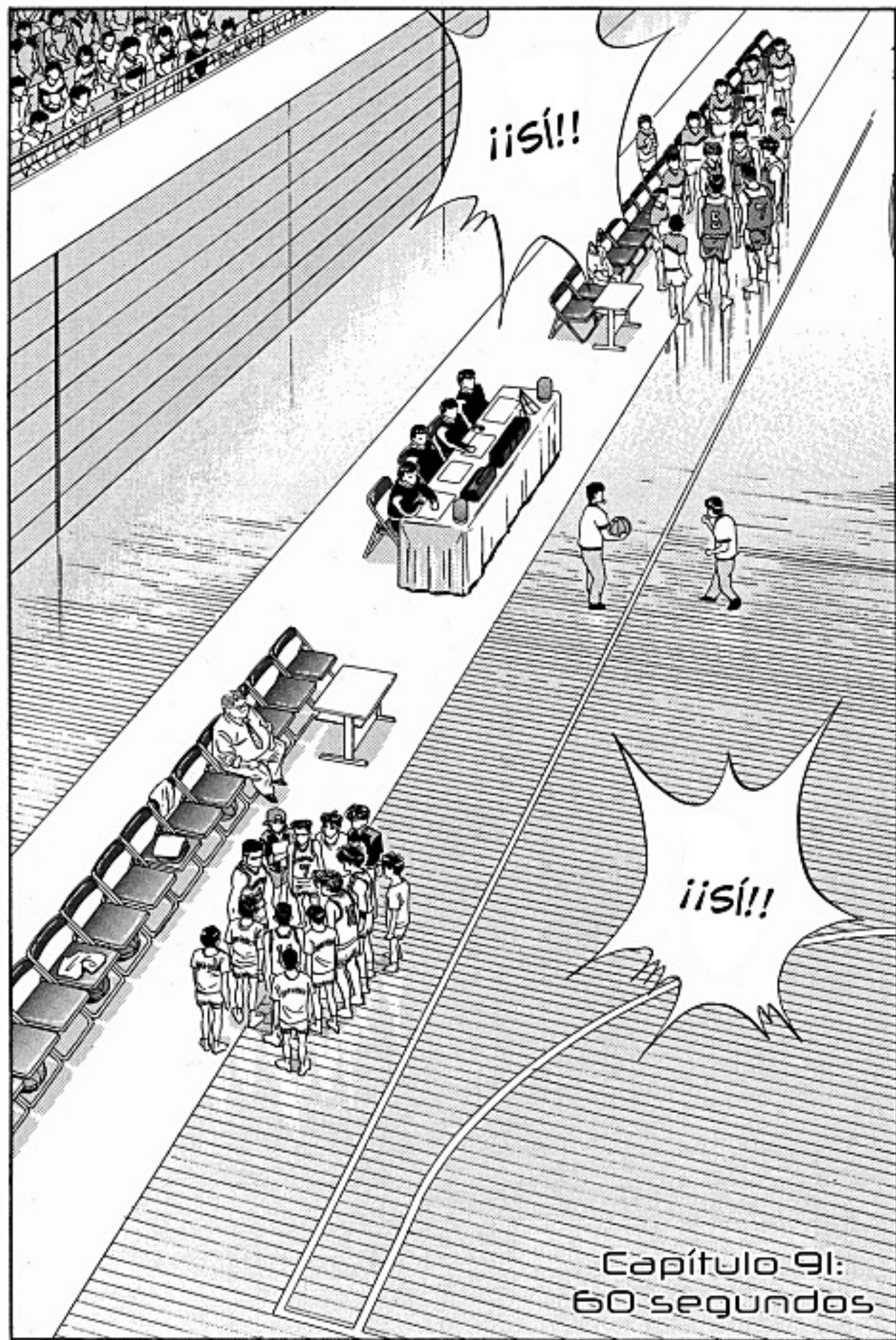

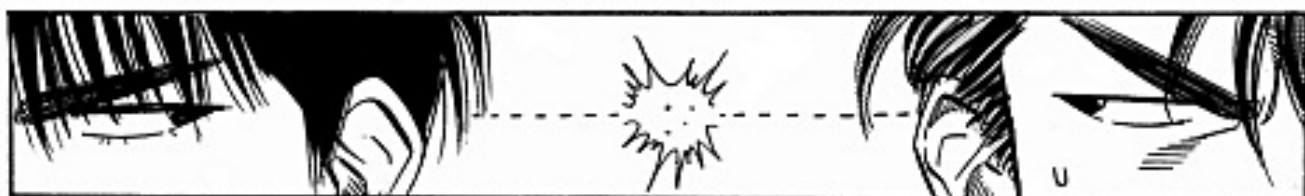
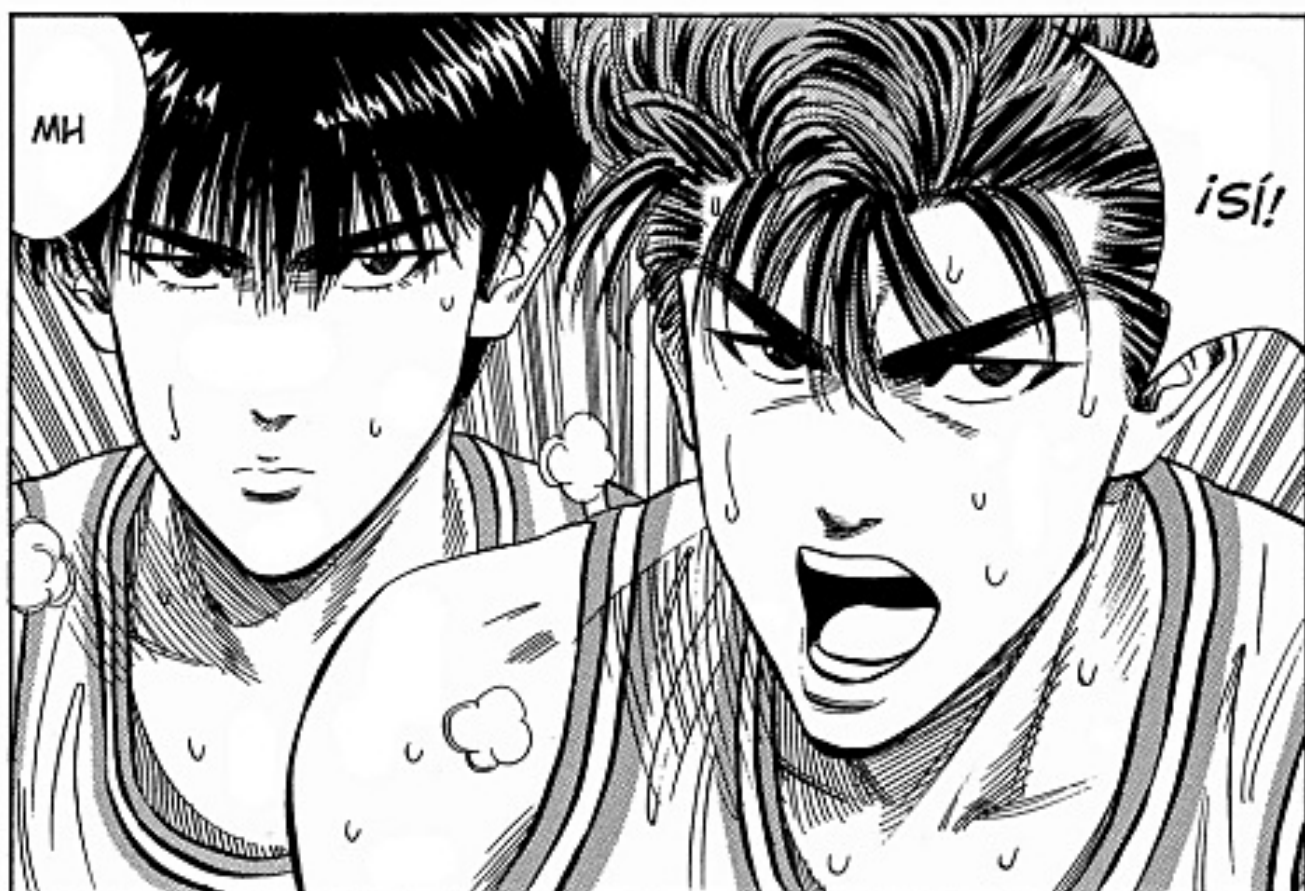
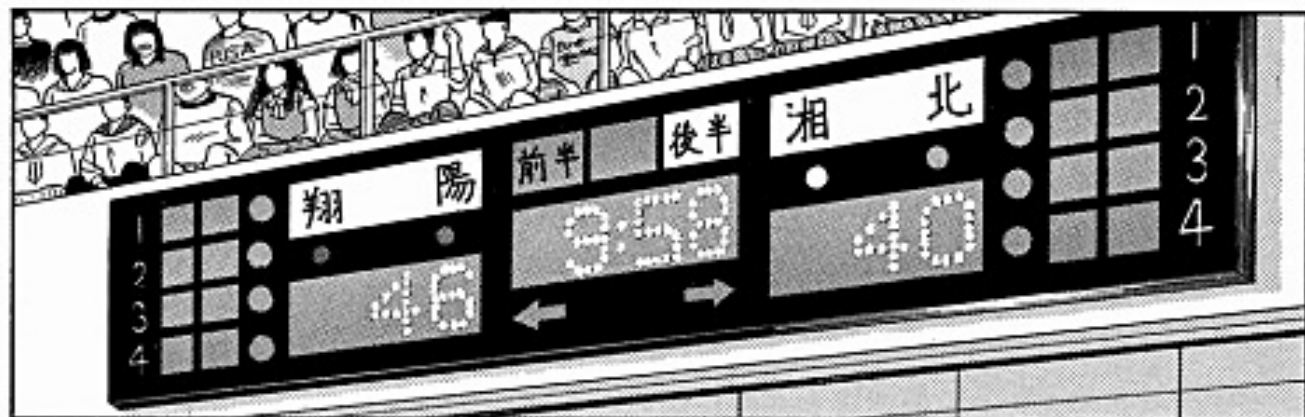

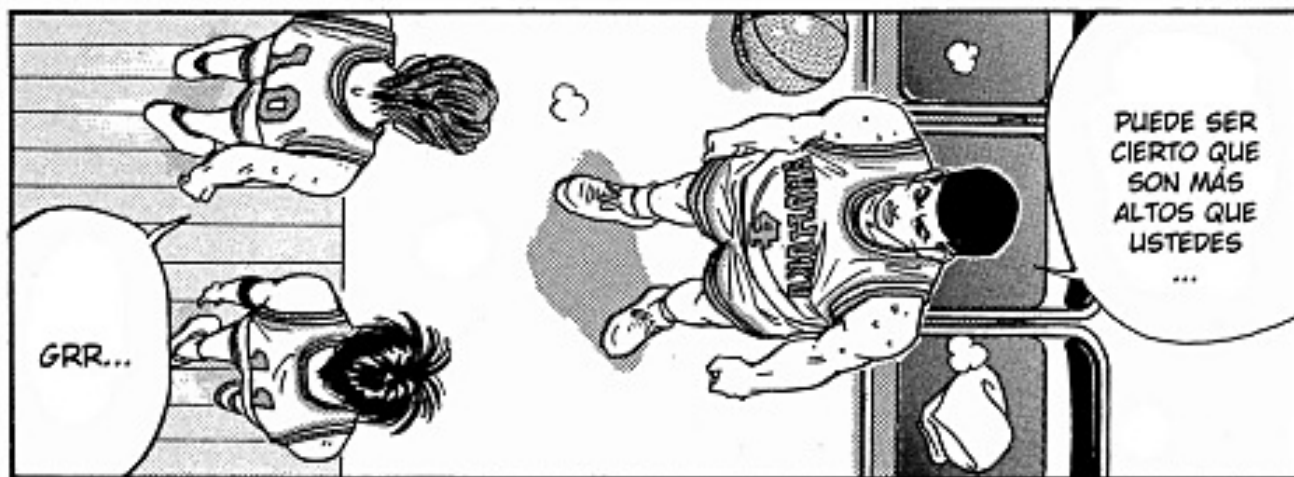



¡PODEMOS
CONTROLAR
EL JUEGO
AÉREO...!

PERO, AÚN
ASÍ, ¡SU
HABILIDAD
SALTANDO
ES MEJOR
QUE LA DE
ELLOS...!

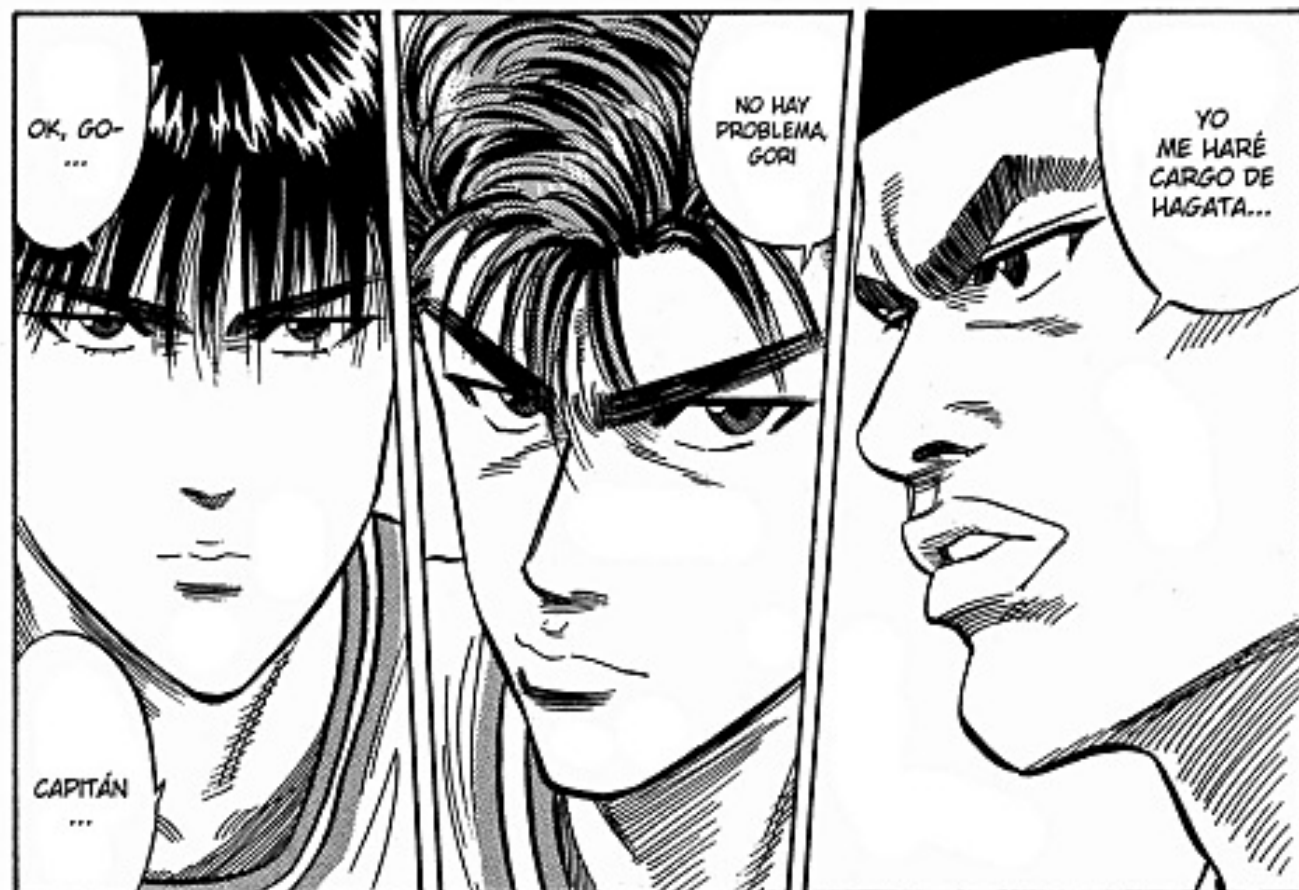

OK, GO-
...

NO HAY
PROBLEMA
GORI

YO
ME HARÉ
CARGO DE
HAGATA...

CAPITÁN
...



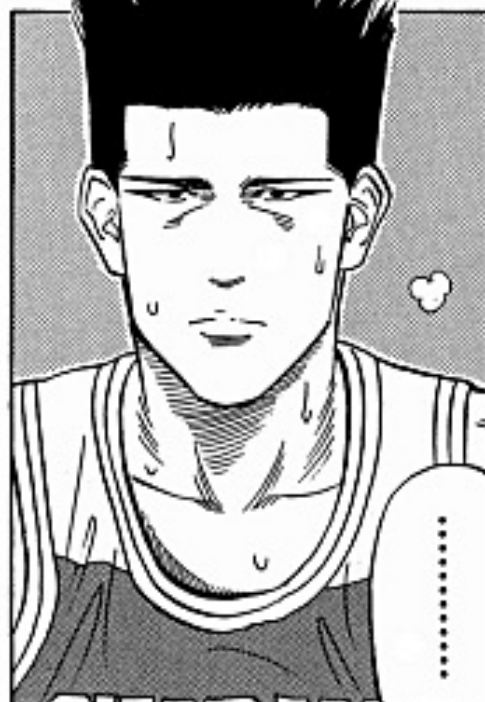

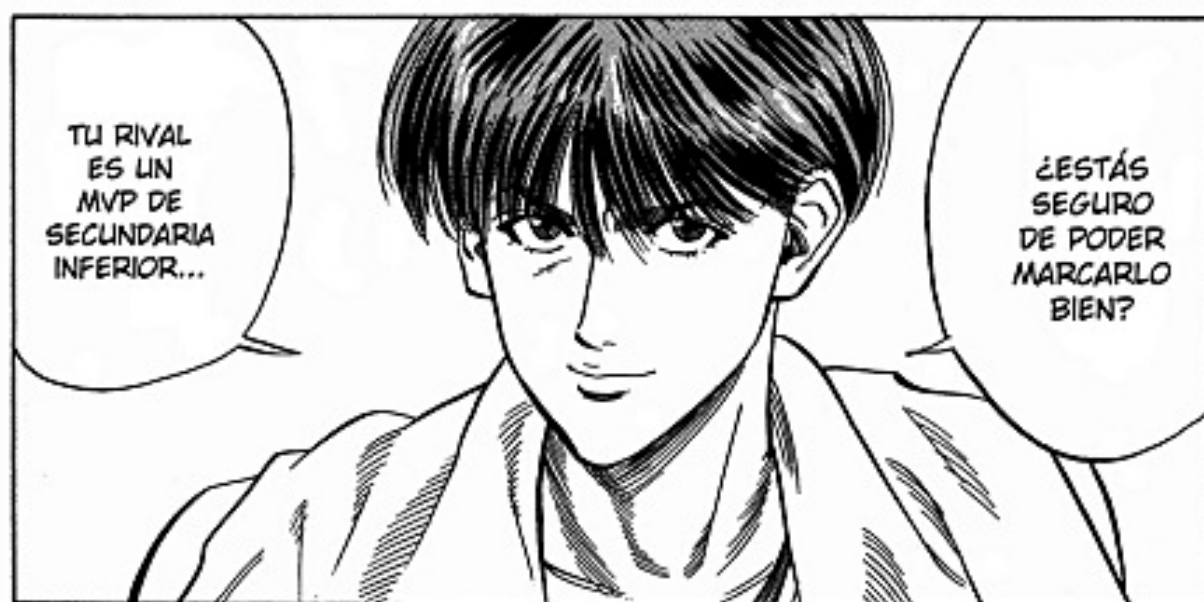

Box And One: La defensa se concentra en detener especialmente a un jugador, enviándole un defensa para marcarlo personalmente, mientras, los otros 4 jugadores defienden zonalmente en forma de una caja







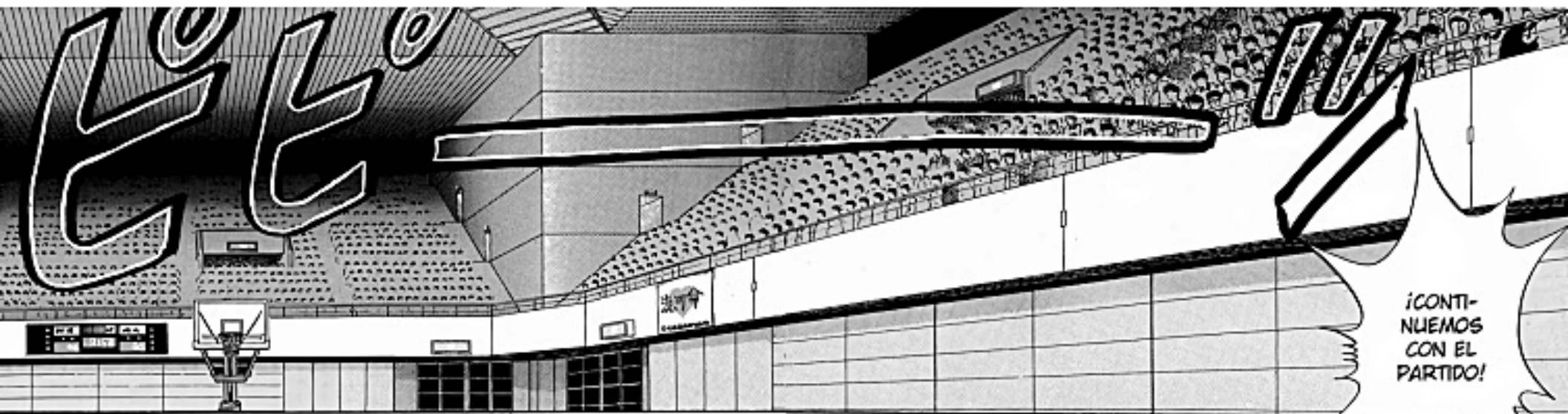

¡CONTINUAMOS CON EL PARTIDO!



RUKAWA.

TÚ PUEDES...



¡Y RUKAWA?

DOS

¿CUÁNTOS PUNTOS LLEVO, ANAKI?

CATORCE



NO HACE FALTA QUE TE PREOCUPES, HARUO, EL SEÑOR SAKURAGI NO CERÁ EXPULTADO EN ESTE PARTIDO!

¡Y VOY A CONTROLAR TODOS LOS REBOTES!



¡TENGO QUE ANOTAR MÁS PUNTOS QUE ÉL!



¡HARUKO!



¡SAKURAGI!

¡TEN CUIDADO, YA TIENES TRES FALTAS!



POSE DE VICTORIA

¡OBSÉRVAME
MUY BIEN,
HARUKO!



Ahh





**SLAM
DUNK**

capítulo 92:
Hacia la victoria

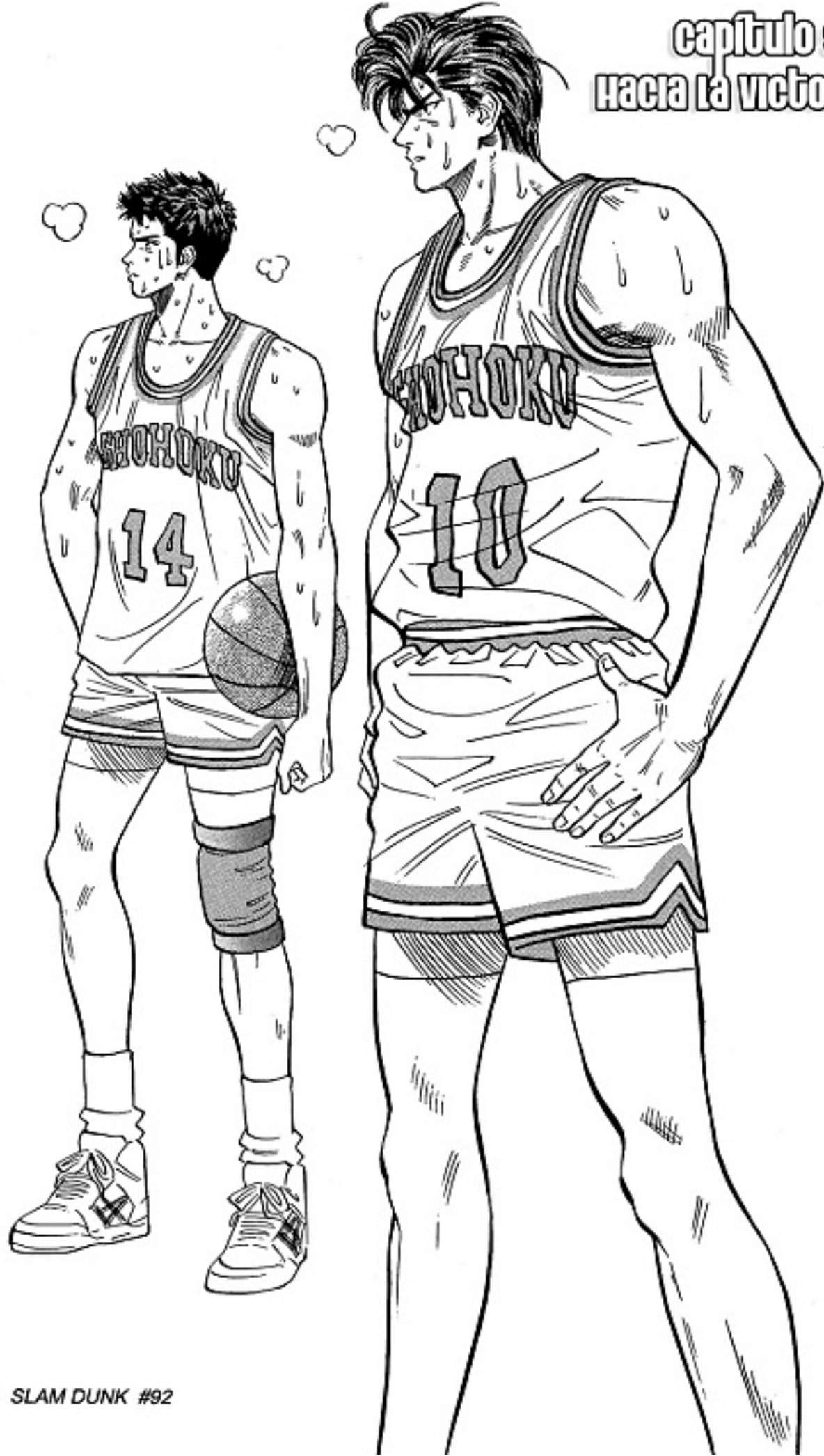





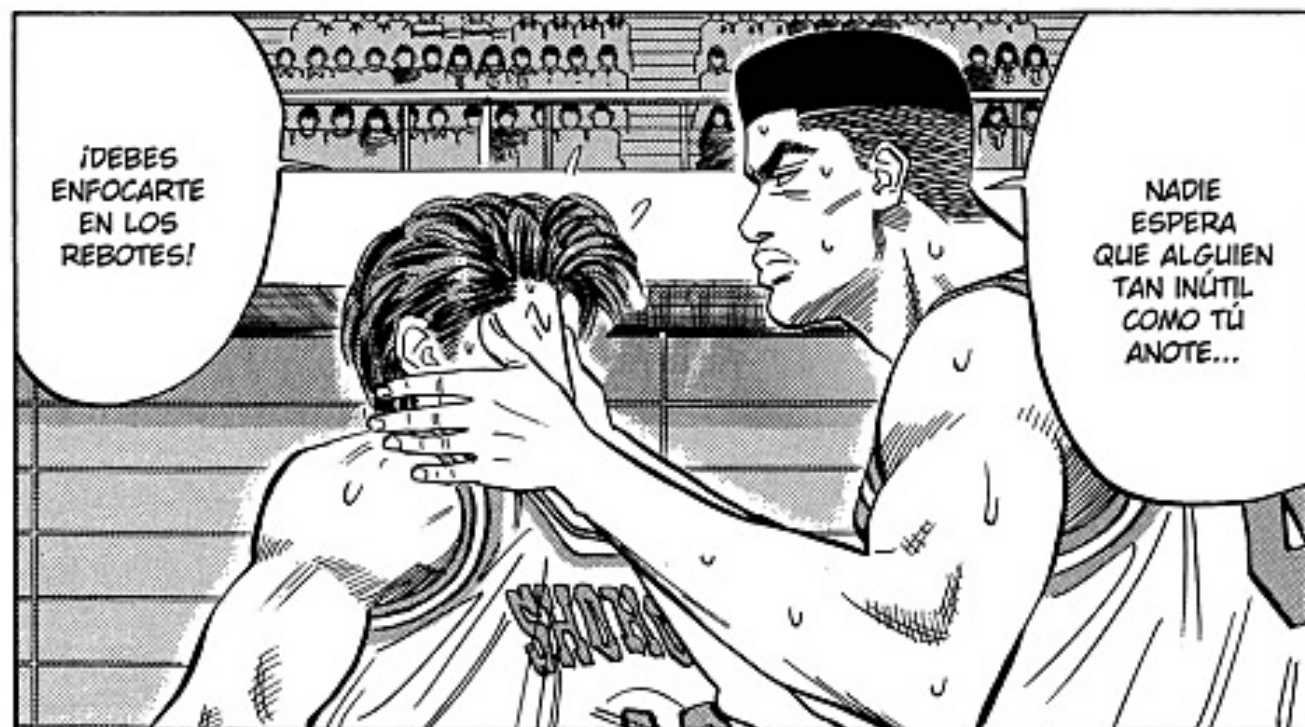









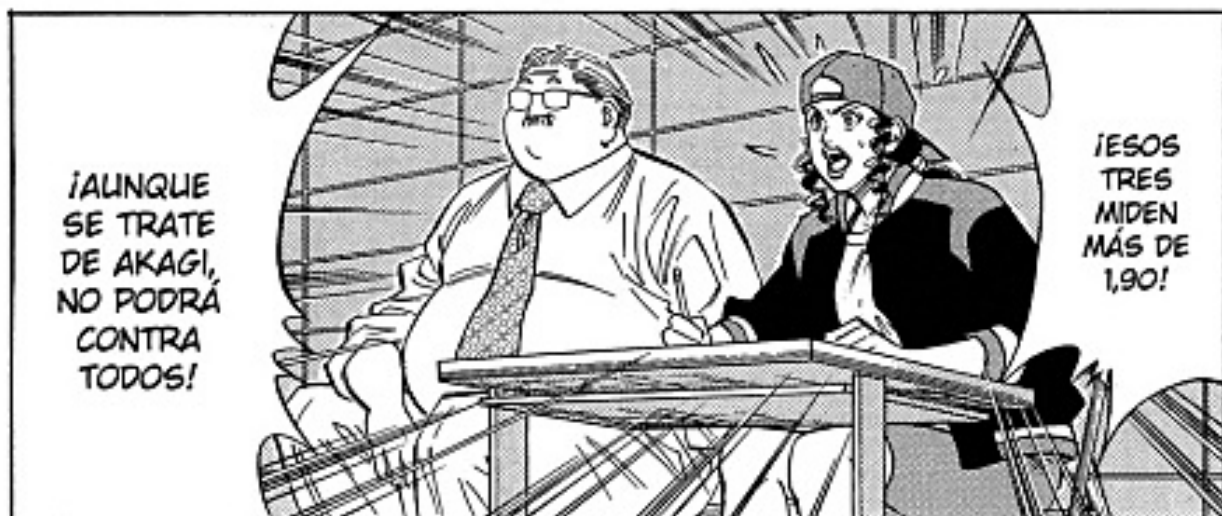

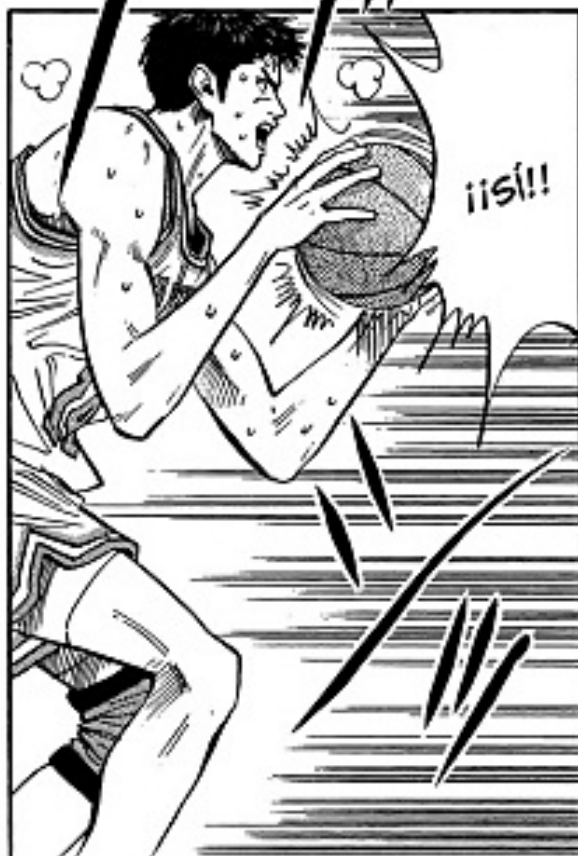
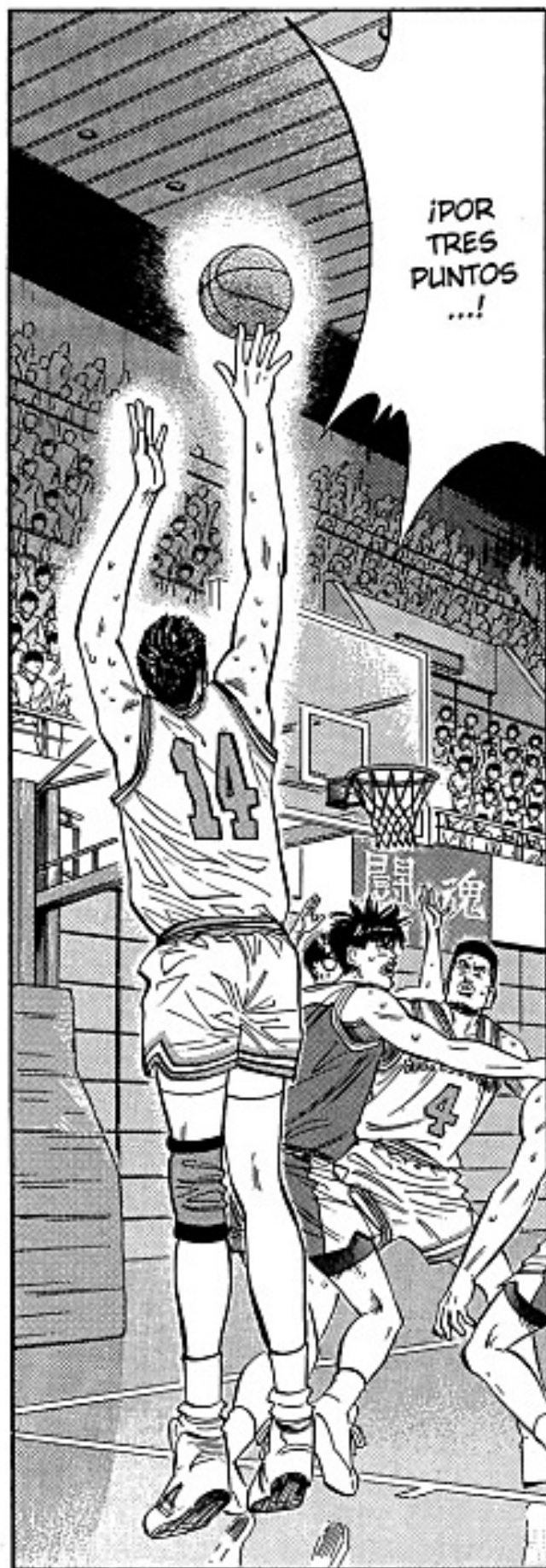





¡KAZU-SHI!



¡HASE-GAWA!

¡MUY BIEN TAPÓN!

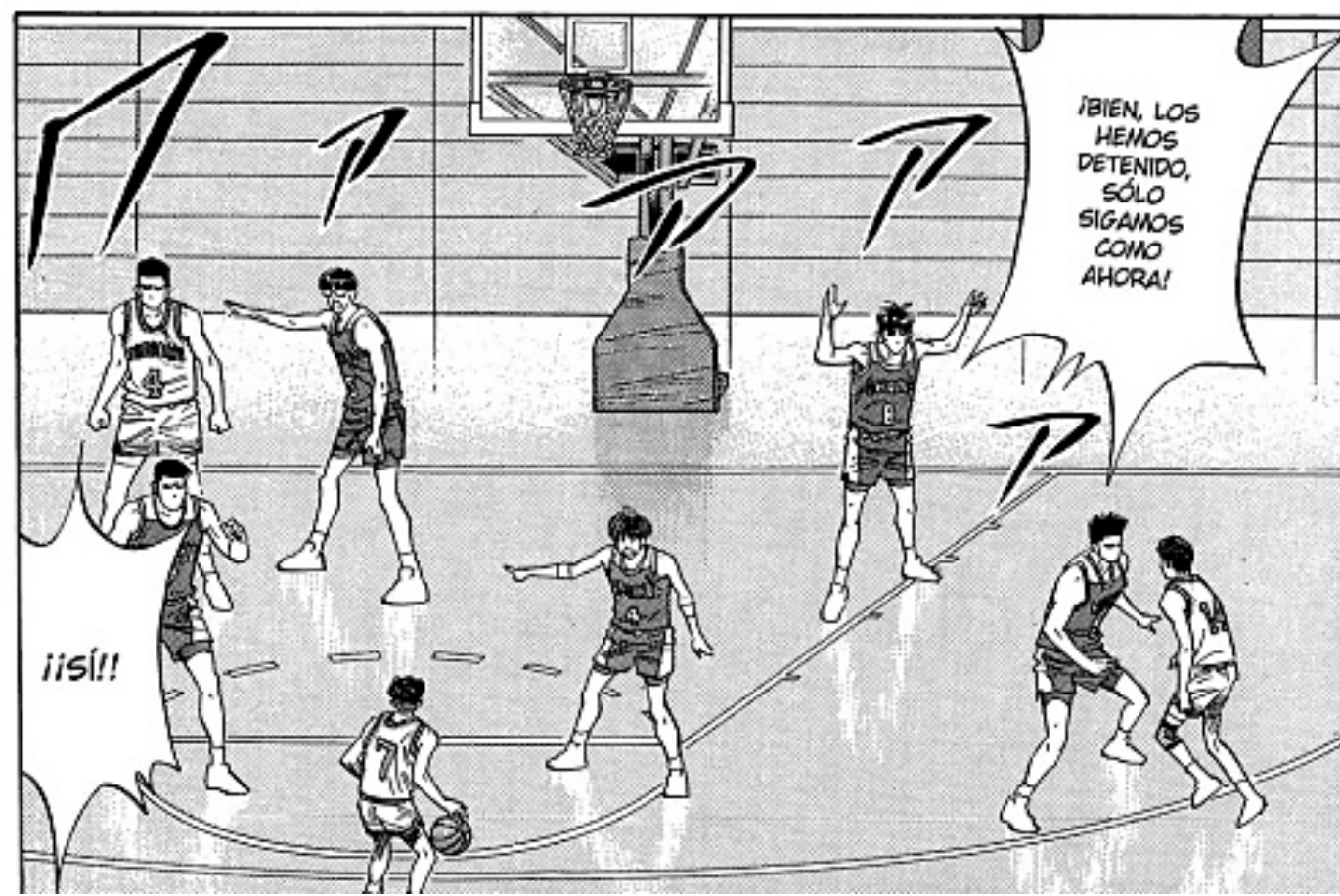



¡Mientras yo esté en Shohoku, el equipo no perderá jamás!

¡NO TE PREOCUPES, MITSU!



¡PERO NO QUIERO TERMINAR CON MENOS PUNTOS QUE RUKAWA!

¡YA DEMOSTRÉ QUE EL GENIO SAKURAGI ES EL MEJOR CON LOS REBOTES, EN TODA LA PREFECTURA.



¡ES ALGO UN POCO DIFÍCIL!

いっしょ

PERO...
GANAR 11 PUNTOS EN LOS MINUTOS QUE QUEDAN.



QUE DEJE CON LA BOCA ABIERTA A RUKAWA Y TODO SHOYO...

LO QUE NECESITO ES UNA OPORTUNIDAD PARA REALIZAR UN TIRO ESPECTACULAR...





¡DEFEN-
SA!

¡DEFEN-
SA!



¡MUY BIEN!!



¡BLAGH
...!

¡VAMOS,
EQUIPO!



¡NUNCA
HABÍA
TENIDO
QUE JUGAR
LOS 40
MINUTOS
CON TANTA
ENERGÍA!

ESTE ES
EL PRIMER
PARTIDO
IMPORTANTE
DE MITSUI
DESDE SU
REGRESO



TIENE QUE
MOVERSE
MUCHO PARA
LIBRARSE
DE SU
MARCA...

ESTÁN
MARCANDO
PERSONAL-
MENTE A
MITSUI

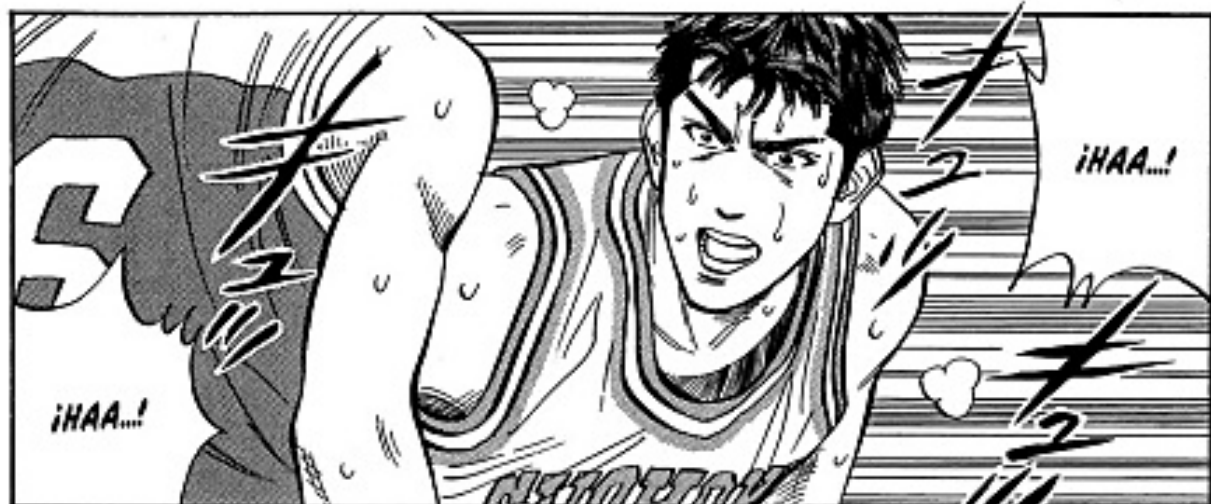

¡HAA...!

¡HAA...!



SUS REBOTES NOS HAN MANTENIDO A SALVO DE LOS CONTRA-ATAQUES

GRACIAS A LO MUCHO QUE MEJORÓ SAKURAGI HEMOS PODIDO CONTROLAR EL RITMO DEL PARTIDO...



¡UN TIRO...!



EL RESULTADO DE ESTE JUEGO ESTÁ EN LAS MANOS DE SAKURAGI Y MITSUI...

ELLOS SON LAS FIGURAS CLAVES...



NECESITAMOS LA ENORME FUERZA DE MITSUI PARA CONSEGUIR LA VICTORIA

PERO ESO NO ES SUFICIENTE PARA GANAR



¡¡MIERDA!!

¡HIJO DE PUTA! ¡NO CONSIGO LIBRARME DE ÉL!



¿ESTE TIPO ES ALGUIEN QUE DERROTÉ EN SECUNDARIA INFERIOR...?

¡NO RECUERDO A NADIE CON MOVIMIENTOS COMO ESTOS!



ES POR ESO ...

QUE AUNQUE ESTÉ AGOTADO, NO PUEDO SACARLO DEL JUEGO ...

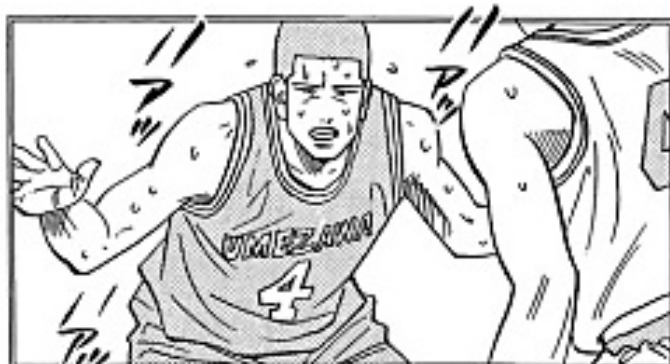



**SLAM
DUNK**









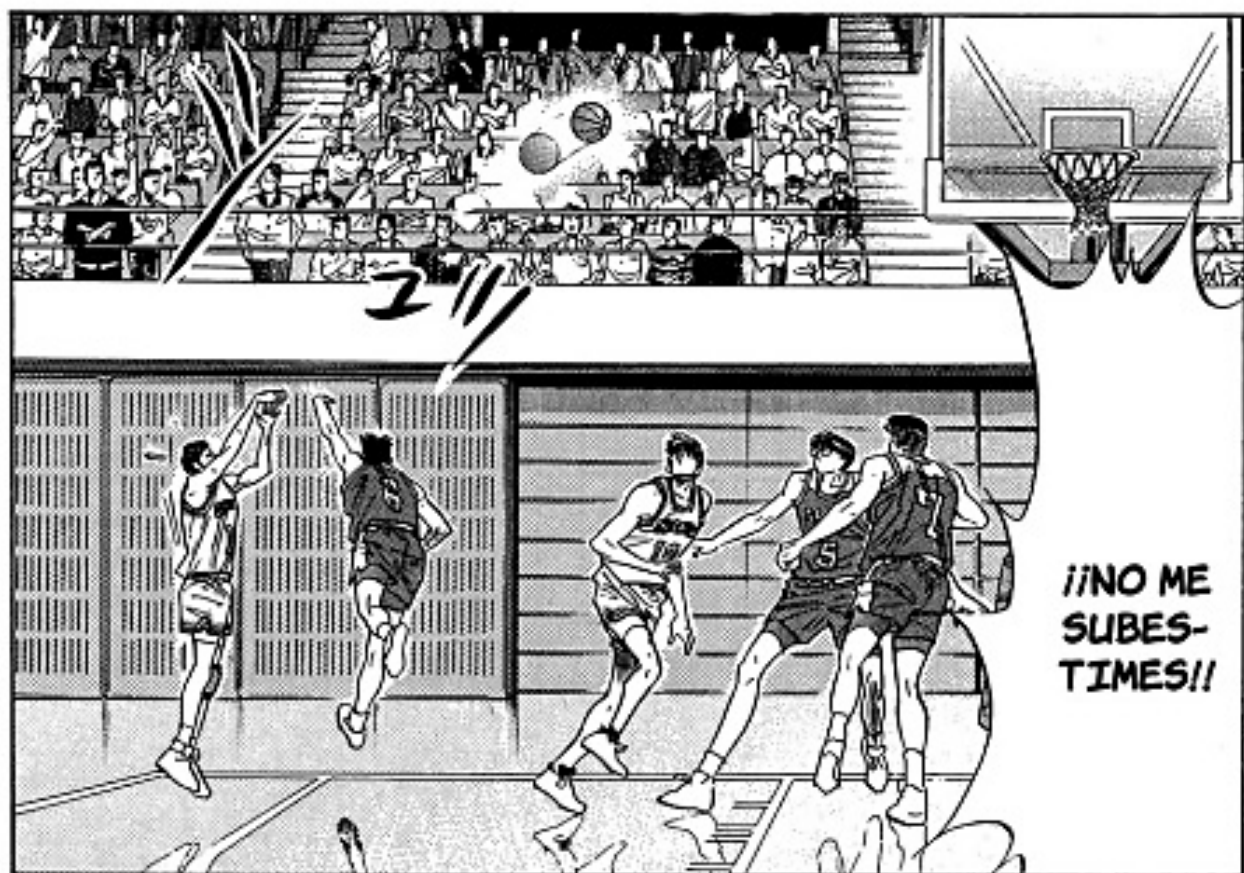
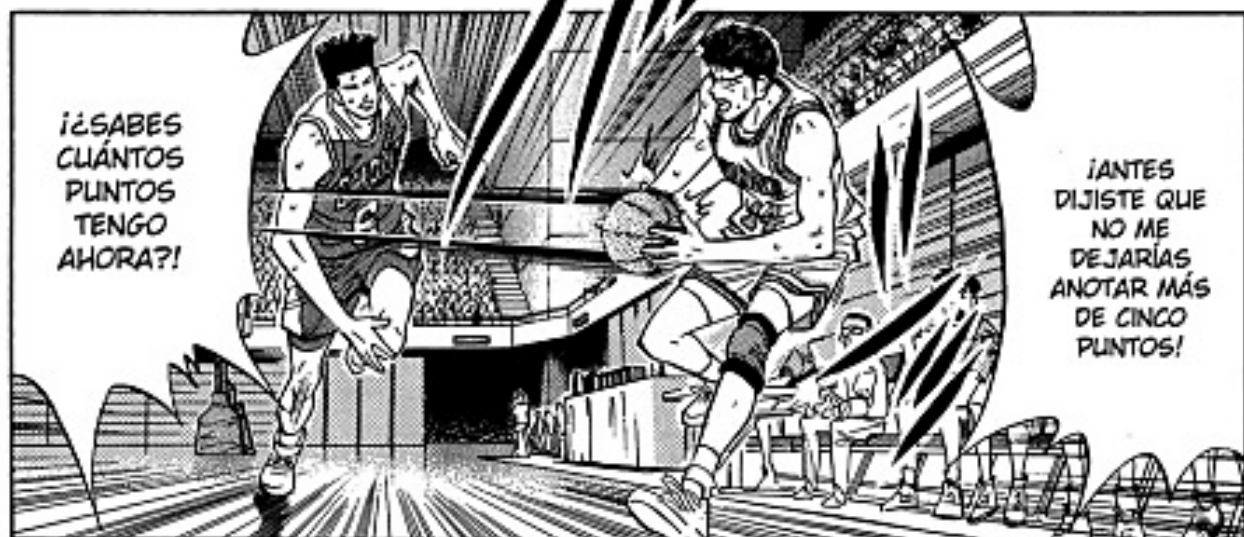



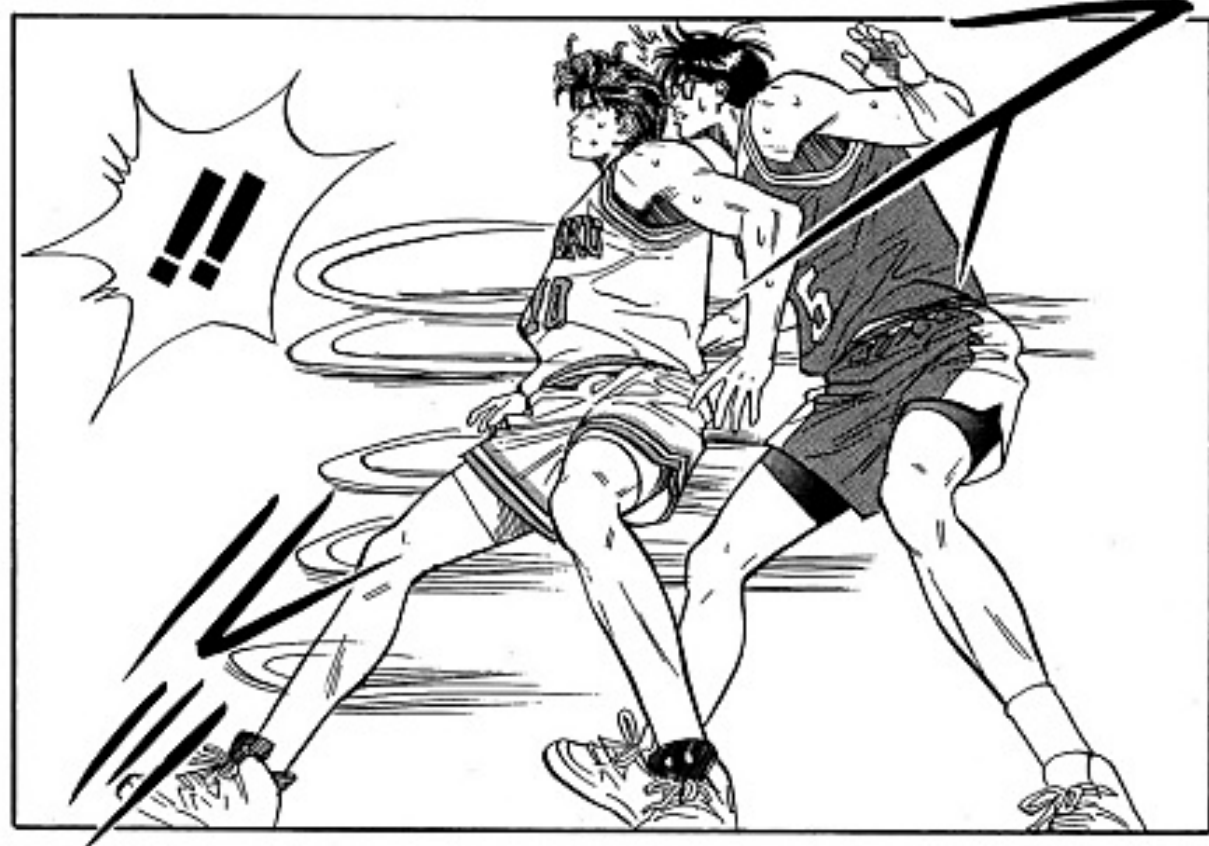

¡ES
SAKURAGI,
EL REY
DE LOS
REBOTES!



¿QUÉ?!





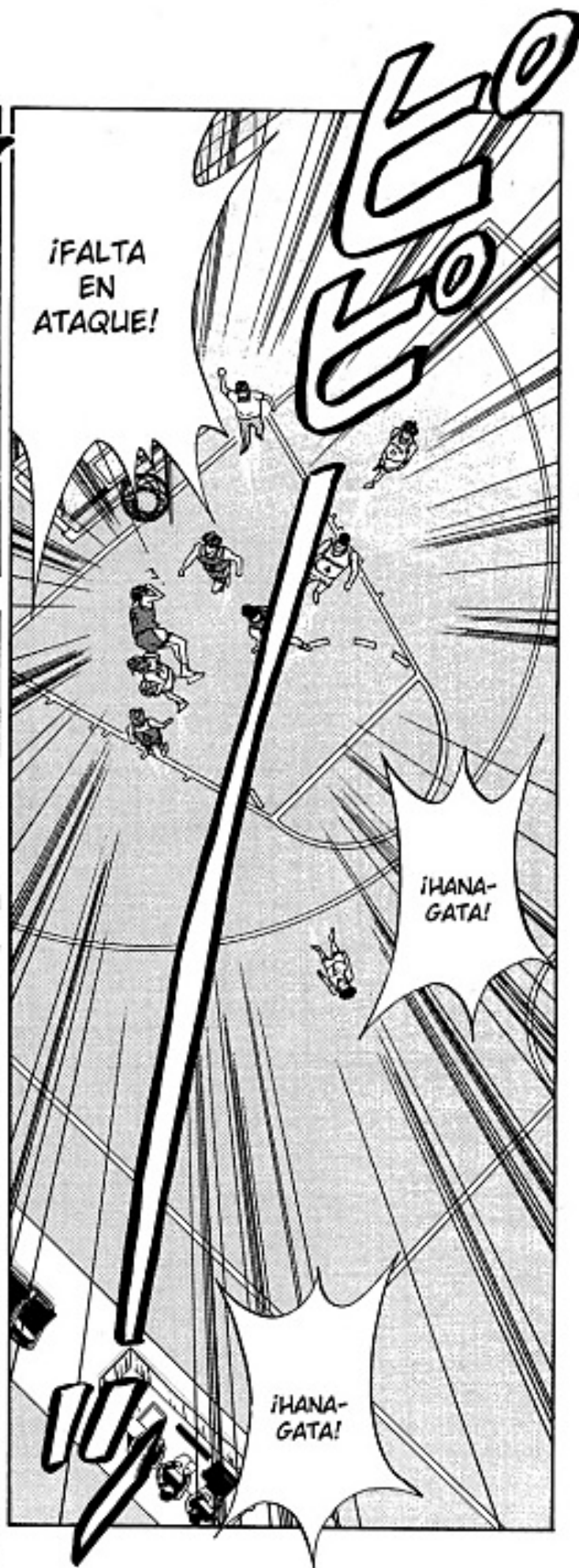



¡SI!



¡ITO!
¡ALÍSTATE
PARA
JUGAR!

¡HANA-
GATA!
¿ESTÁS
BIEN?!



¡LO NECESITAMOS
PARA PELEAR
LOS REBOTES!

¡NO PODEMOS
SUSTITUIR A
HAKAGATA EN
ESTE PARTIDO!





CON ESTO,
SAKURAGI
YA TIENE 4
FALTAS



¡DEBEMOS
DERROTAR
A SHOHOKU
A COMO DÉ
LUGAR!

¡TENEMOS
QUE VENCER
Y PASAR
A LAS
FINALES!



¡HANA-
GATA!



¡¡SI!!

Al perder toda su agresividad, el N°10, Sakuragi, perdió su efectividad, en defensa y en los rebotes



¡RAYOS, DEBO TENER CUIDADO!

¡HANA-GATA!



Gracias a esa falta, el partido volvió a estar en las manos de Shoyo

¡VAMOS, HANA-GATA!

El N°11, Rukawa, se valió de su habilidad para anotar con varias jugadas individuales, pero no pudo cambiar mucho la situación



Sacando ventajas de la altura de sus jugadores, Shoyo anotó por el centro varias veces

Sólo quedan 5 minutos en el partido, y la ventaja sigue aumentando









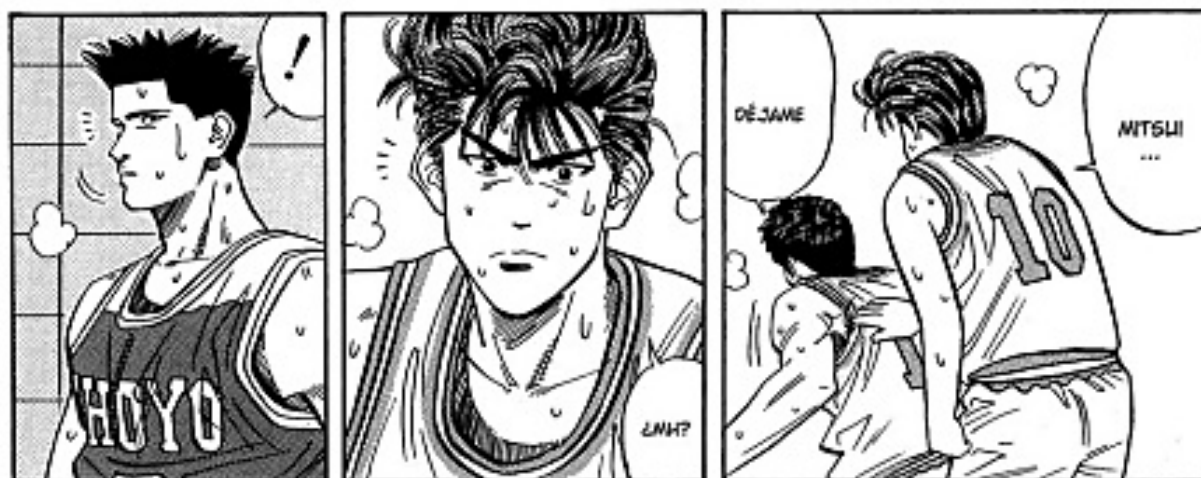



MITSUI

...

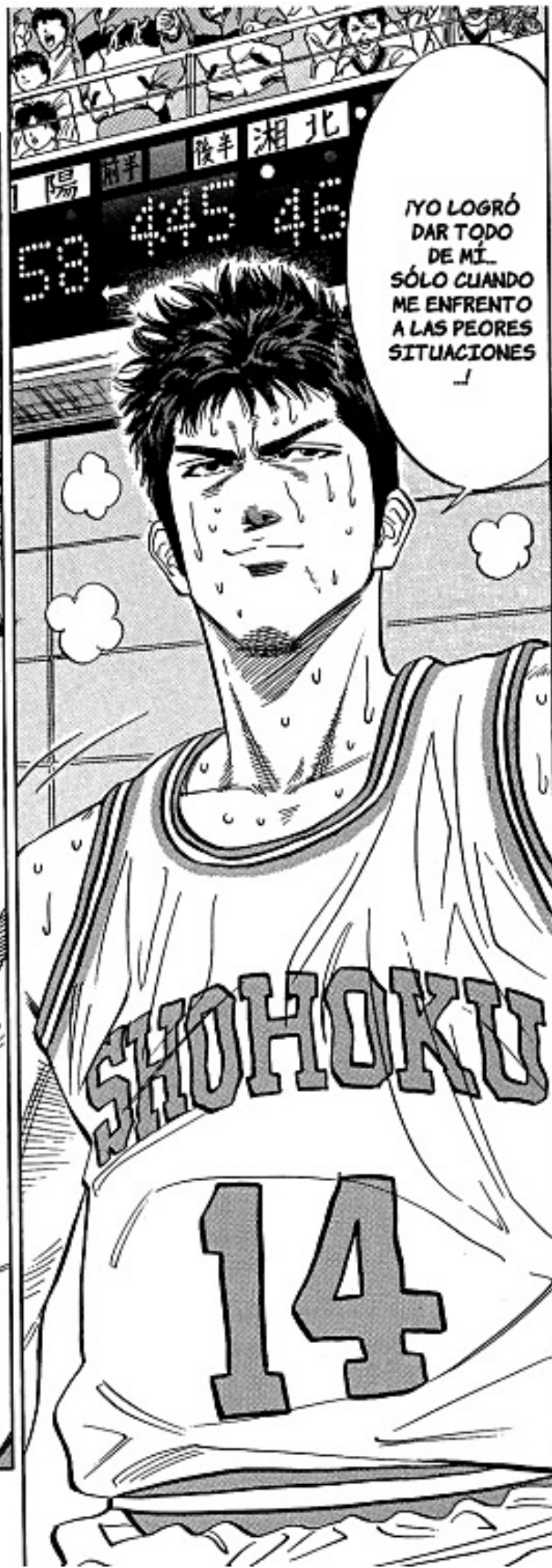

YO LOGRÉ
DAR TODO
DE MÍ...
SÓLO CUANDO
ME ENFRENTÉ
A LAS PEORES
SITUACIONES
└

**SLAM
DUNK**

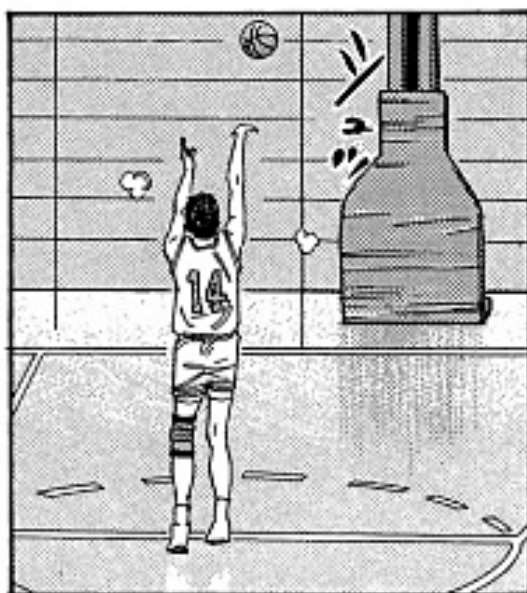
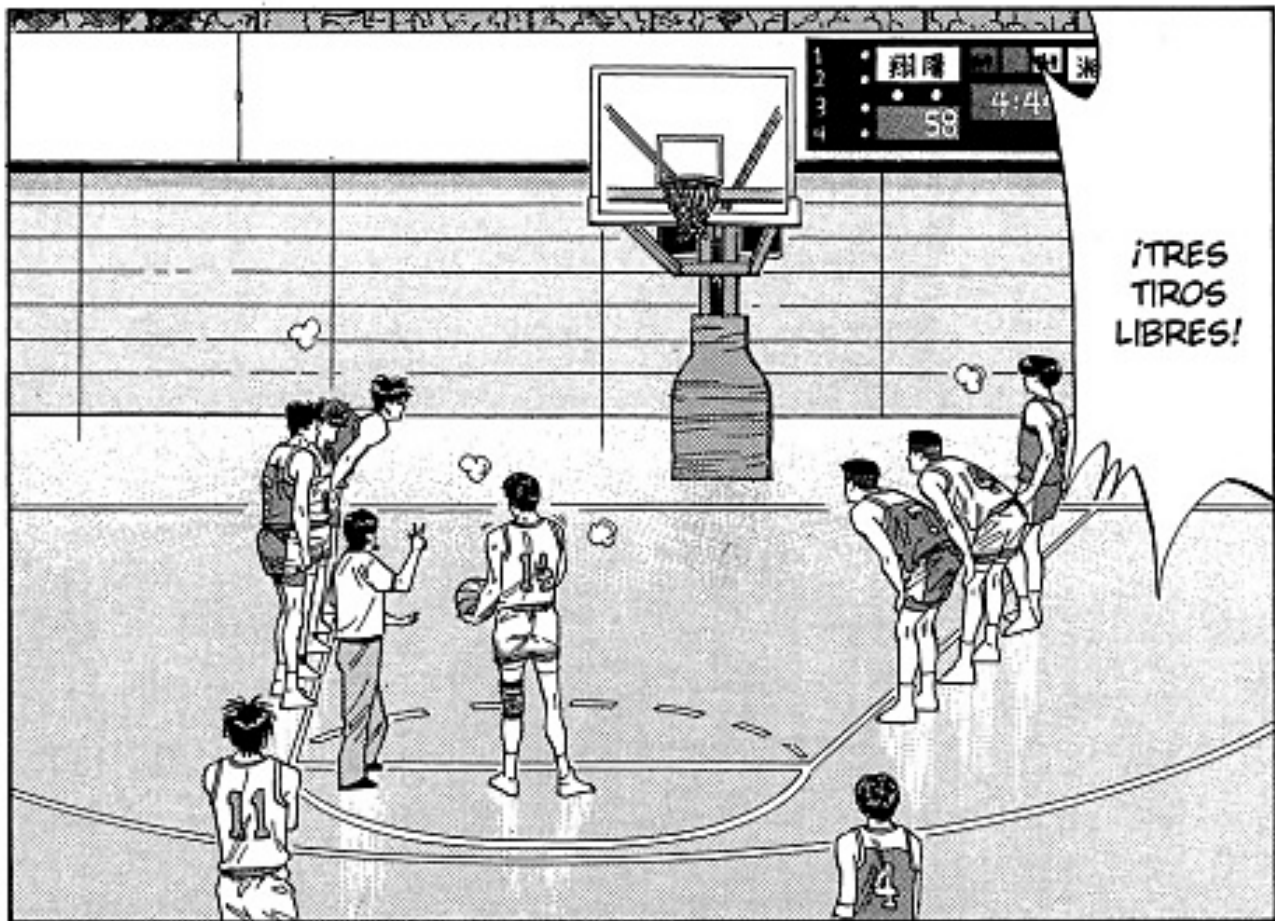

¡PARA
APROVECHAR
TODA MI
HABILIDAD!

QUIERO
SEGUIR CUANTO
ANTES CON
EL PARTIDO
...

capítulo 94:
maldito estúpido





¡58 A 49!

¡METIÓ
LOS 3
TIROS!



¡ANOTAMOS
UNA
CANASTA!

¡¡sí!!



¡PERO
SÓLO
FALTAN
CUATRO
MINUTOS!

¡Y TIENEN
NUEVE
PUNTOS DE
DIFERENCIA!

¡MITSUI
HA VUELTO
A SER LA
ESTRELLA
DE ANTES!



¡¡WAWAW!

pero ya
tengo 4
faltas!



¡¡DEBEN
LLEGAR
A LAS
FINALES!!

¡DEN SU
MEJOR
ESFUERZO,
SHOHOKU
...!



¡MANTEN-
GAN SUS
POSICIO-
NES!

¡NO
RETRO-
CEDAN!



¡MIT-
SUI!



¡MIT-
SUI!



SI SHOHOKU
NO SE ARRIESGA,
ENTONCES NO
PODRÁ GANAR.

ES
LÓGICO
...



¡SHOHOKU
ESTÁ
USANDO
DEFENSA
DE PRESIÓN!

Para los novatos
en esto del Basket:

Usar una defensa
de presión es algo muy
impresionante, ya que es una
defensa extremadamente
agotadora por
ocupar toda
la cancha

← seki-lacho



¡ERES UN INGENUO! MITSU!
¡JUGAR UNA DEFENSA COMO ESA
EN ESTOS MOMENTOS!

¡NO LO SOPORTARÁS!

¡PARECE
QUE HAN
DECIDIDO
APOSTAR
TODO LO
QUE TIENEN!





El momento en que Hasegawa dudó en atacar, fue aprovechado por Miyagi



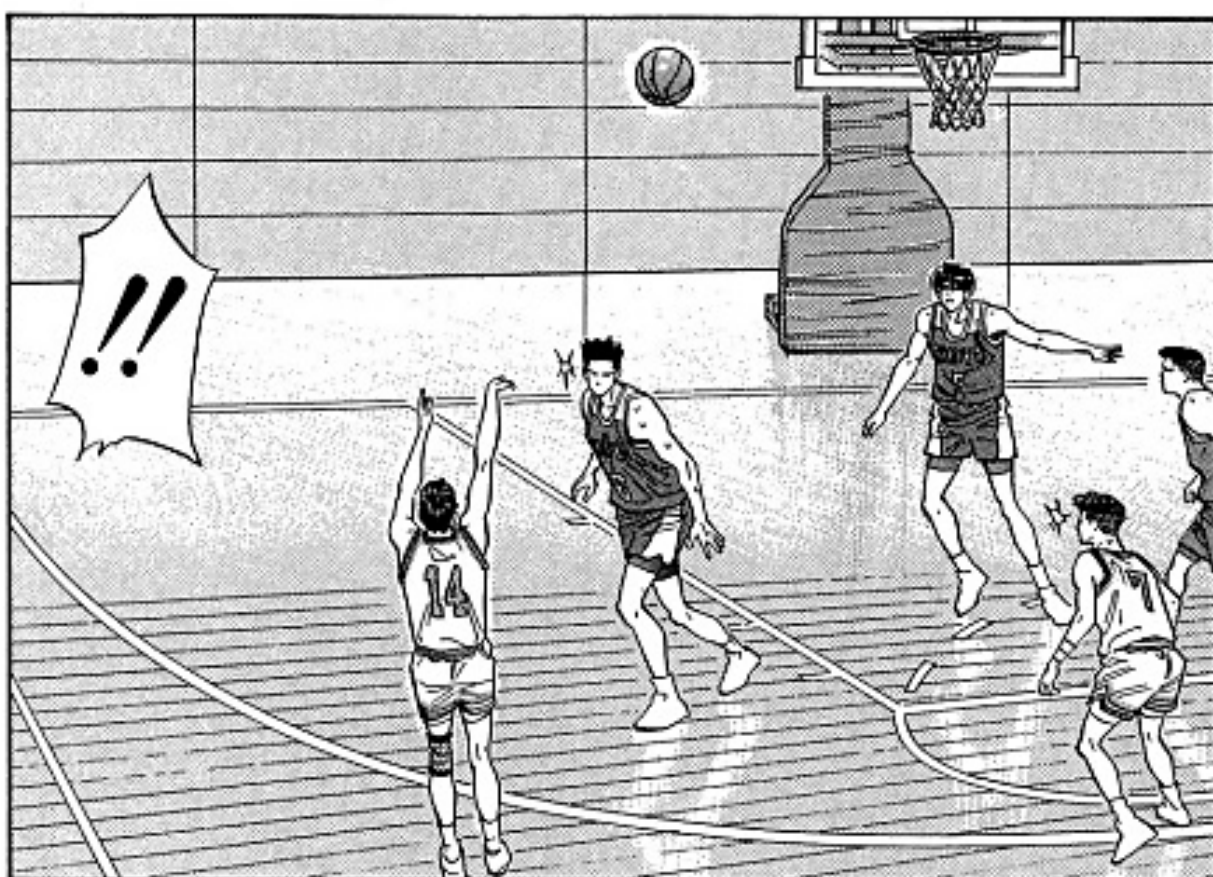



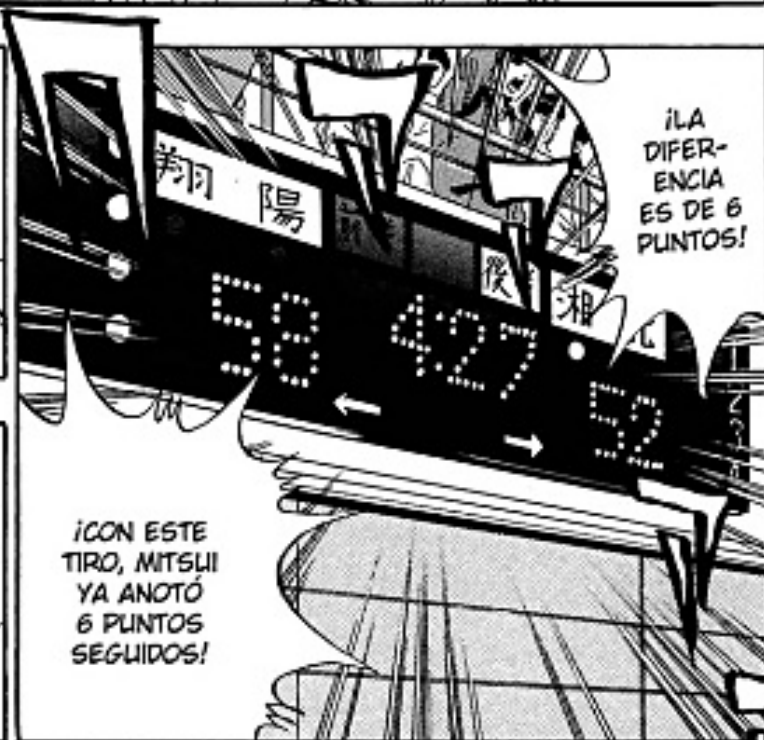



Si no doy
todo de mí
en este
momento...



Entonces
no seré
más que un
maldito
estúpido



¡¡No voy a perder!!

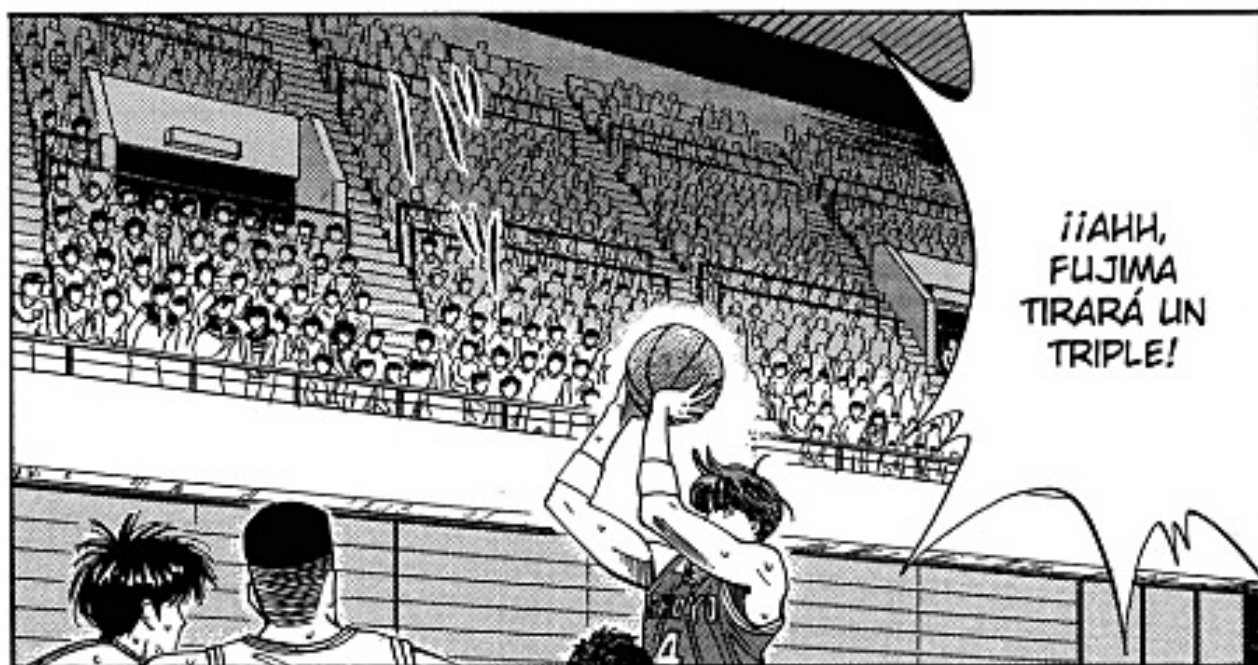

¡¡AHH,
FUJIMA
TIRARÁ UN
TRIPLE!





¡SÍ!

¡CONTRA-
ATAQUE
RÁPIDO.
MIYAGI!

¡¡VAMOS!!

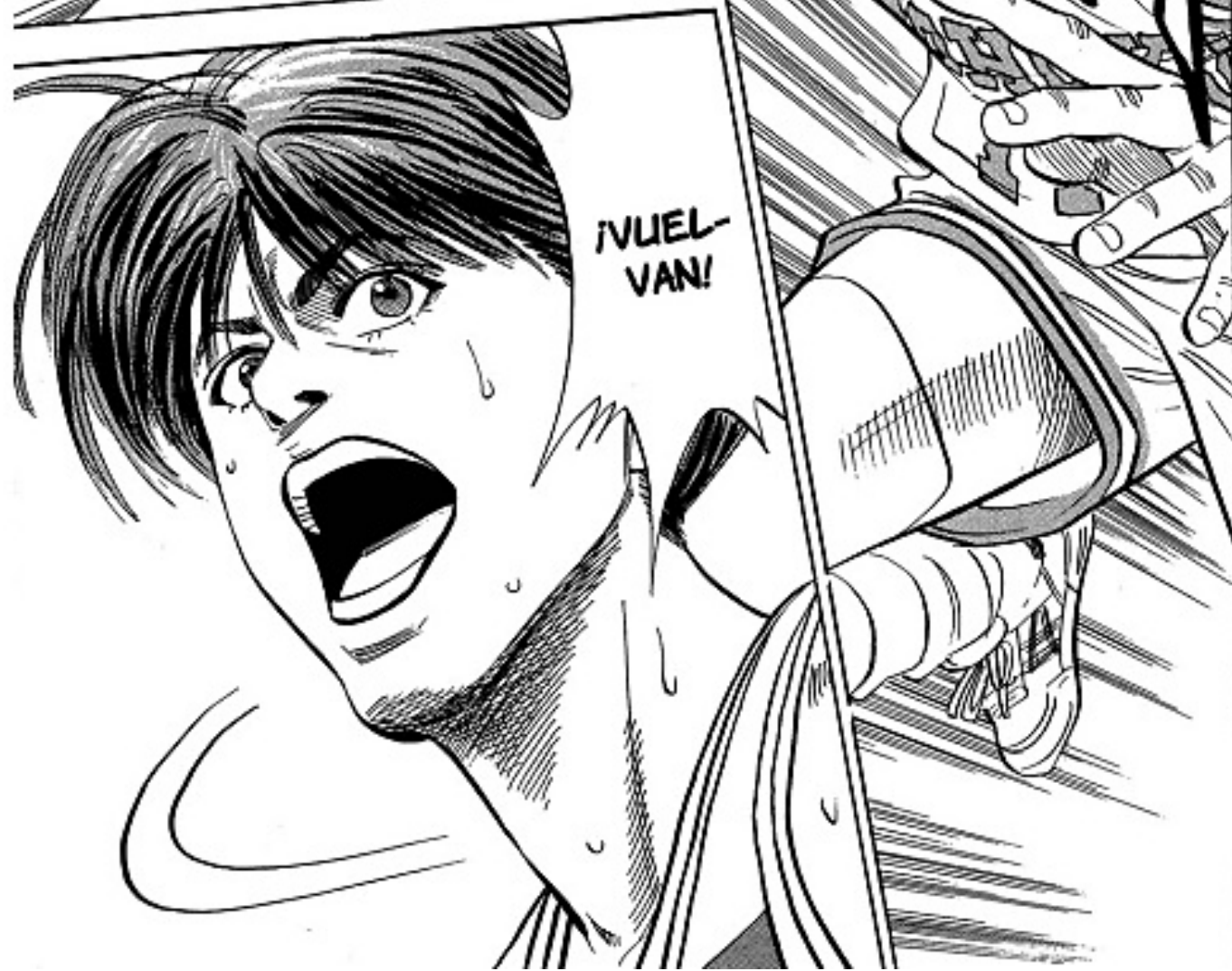

¡VUEL-
VAN!





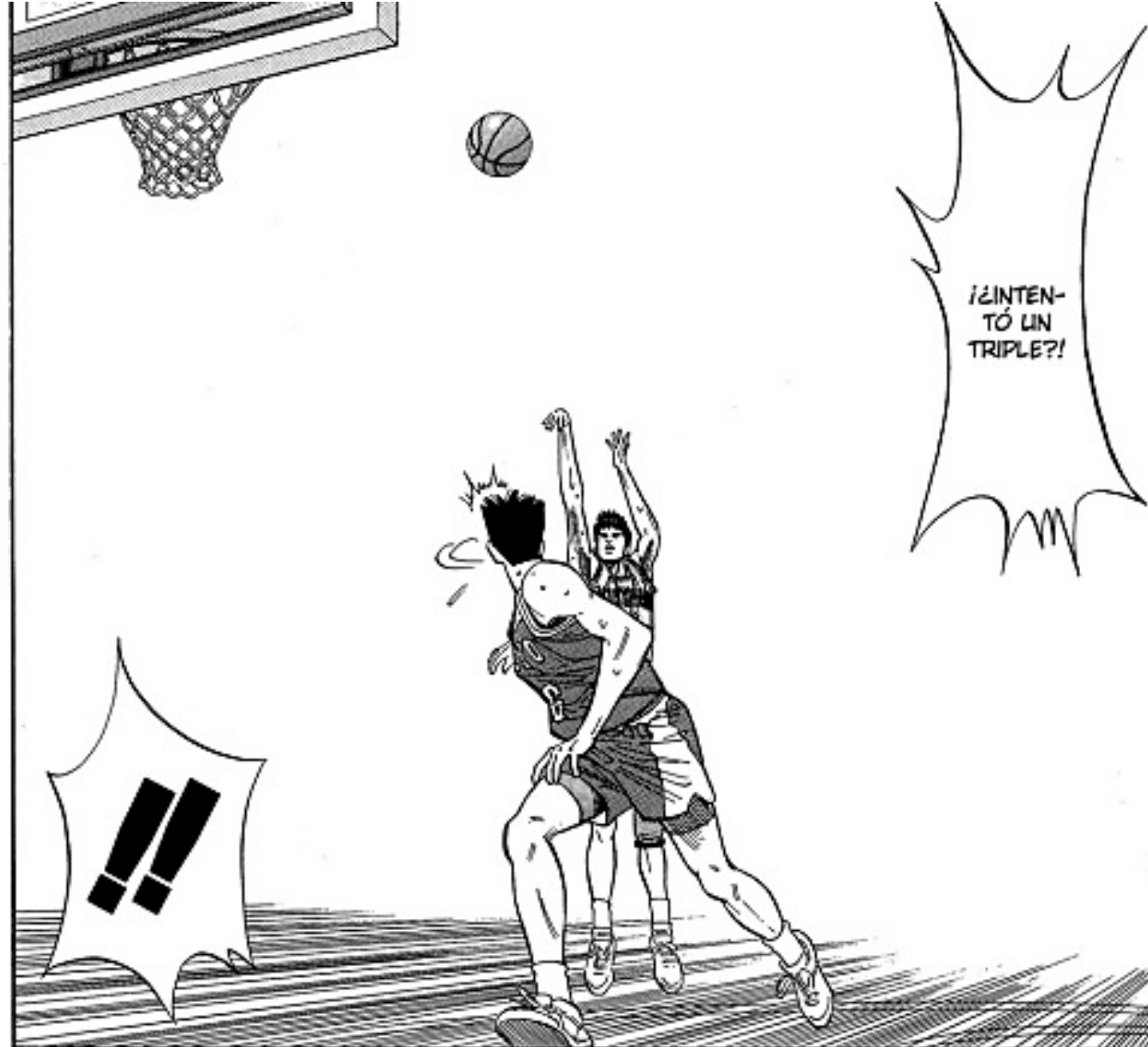



¡EN-
TRÓ!

¿QUÉ DIABLOS
SUCEDE?!
¡SHOHOKU
VUELVE A
ALCANZARLOS!



**SLAM
DUNK**

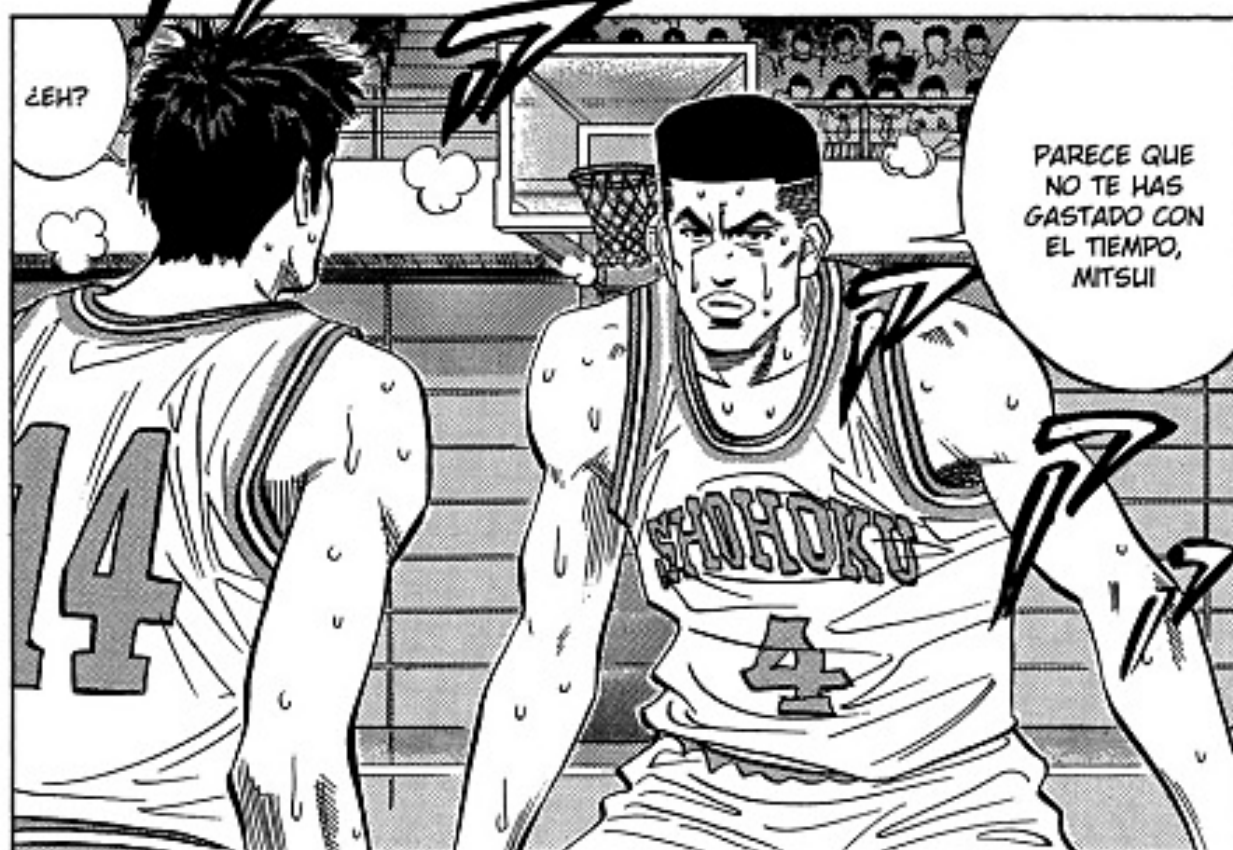

¿EH?

PARECE QUE
NO TE HAS
GASTADO CON
EL TIEMPO,
MITSUI



CÁLLATE

OBLÍGAME

AÚN NO
HE VISTO
QUE PUEDAS
DEMOSTRAR
TU GRAN
HABILIDAD
DE GORILA
...



¿Y QUÉ
PASA
CONTIGO,
AKAGI?



capítulo 95: cuatro faltas







¡MARA-VILLO-SO!

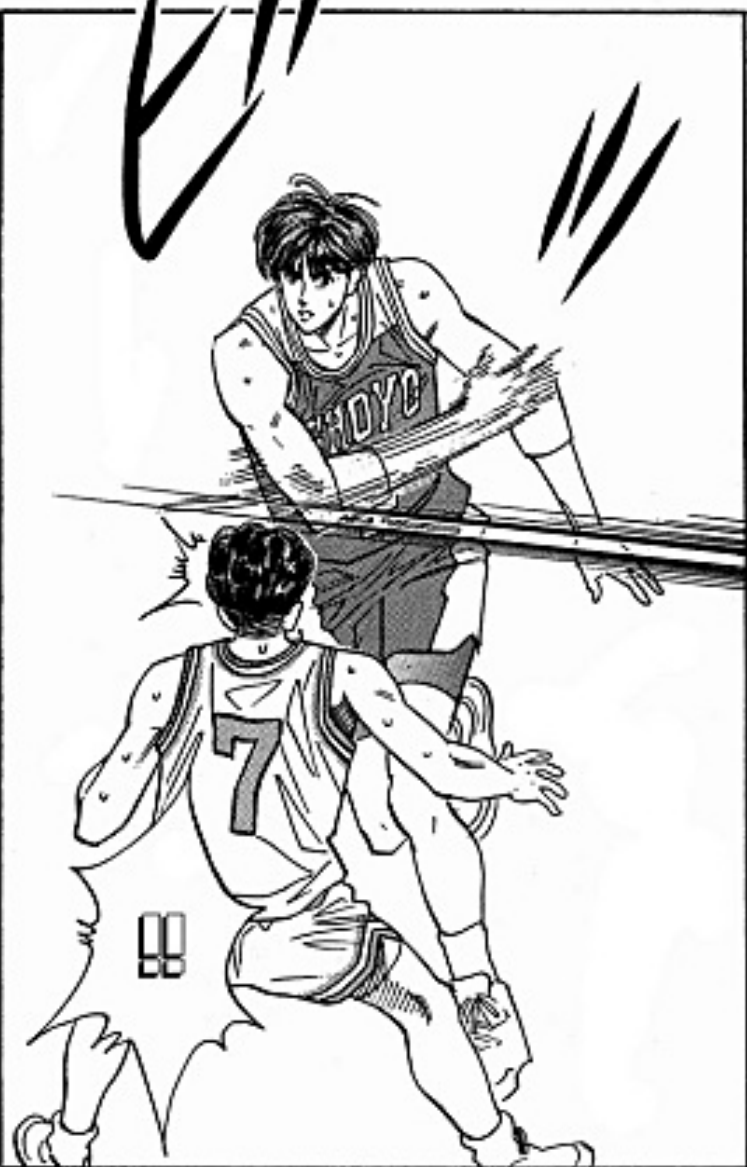

WAA WA...

¡UOH!



¡DETÉNLO, SAKURAGI!

El miedo de cometer otra falta hizo que sakuragi retrocediera



ITAKA-NO!

ITAKA-NO!

ITAKA-NO!



SIN SAKURAGI, LA DIFERENCIA DE ALTURAS SERÍA MÁS GRANDE Y ESTARIAMOS EN PROBLEMAS...

MMH... TIENE MIEDO DE COMETER OTRA FALTA, PERO NO PODEMOS SACARLO, EN VERDAD LO NECESITAMOS EN EL JUEGO



¡ESO ES!



¡SAQUEN VENTAJA DE ESO Y VAYAN CONTRA ÉL!

¡SAKURAGI ES SU PUNTO DÉBIL!

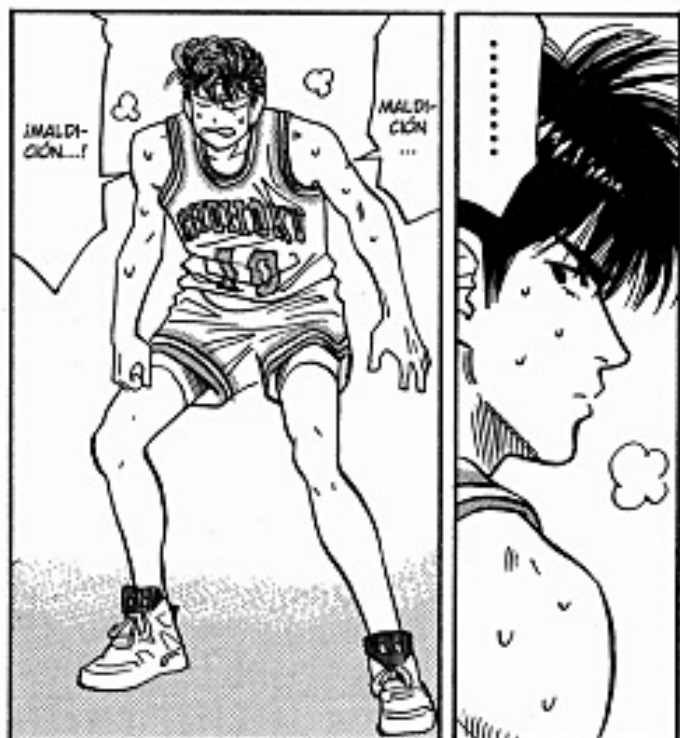





¡ES SU CUARTO TRIPE SEGUIDO!

¡¡ENTRÓ!!

¡NADIE PUEDE DETENER A EL MVP MITSUI!

¡SÓLO HAY 2 PUNTOS DE DIFERENCIA!



¡MITSUI ES ALGUIEN DE TEMER ...!

¡REALMENTE ES EL JUGADOR MÁS VALIOSO!



HAA...

HAA...

HAA...

HAA...



ÉL ES IGUAL QUE YO...



¿CUÁL ES TU OPINIÓN DE MITSUI?

JIN, TÚ TAMBIÉN ERES UN TIRADOR DE TRES PUNTOS



LUNA VEZ QUE HA ENCESTADO, NO PARARÁ DE HACERLO...

SU POSTURA Y MOVIMIENTO SON EN VERDAD EXCELENTE...



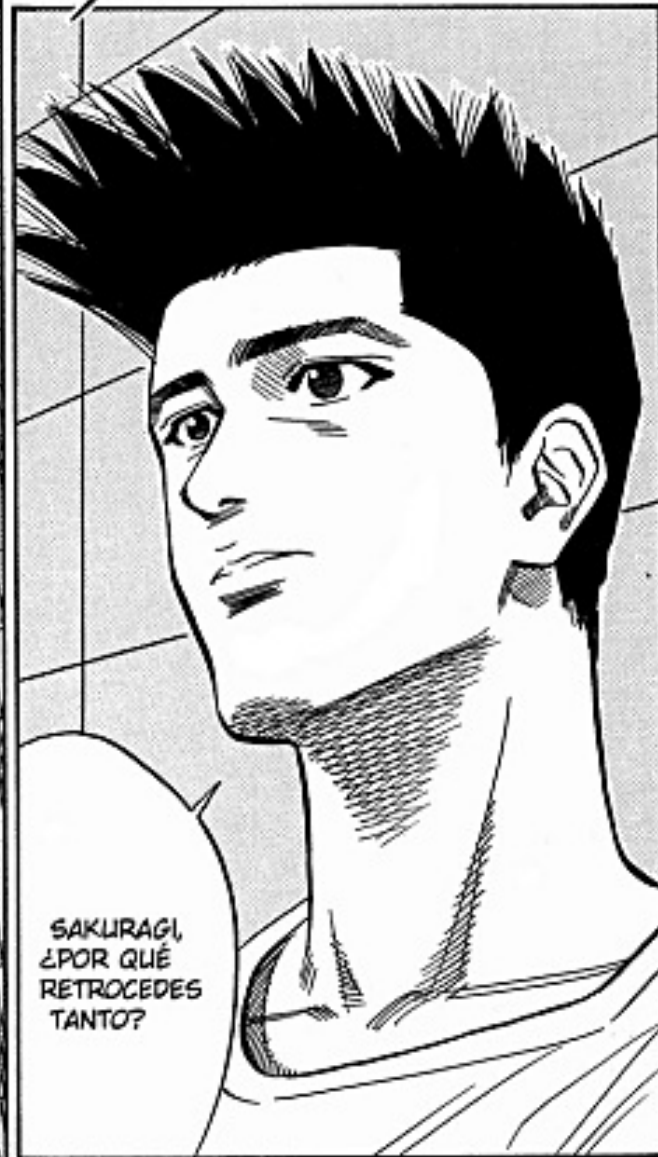



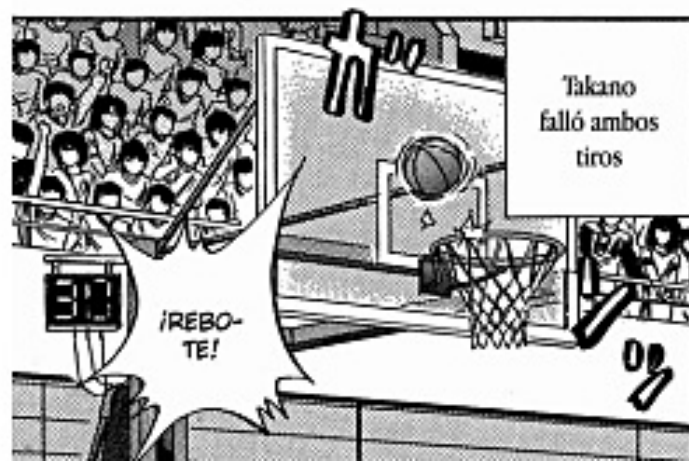
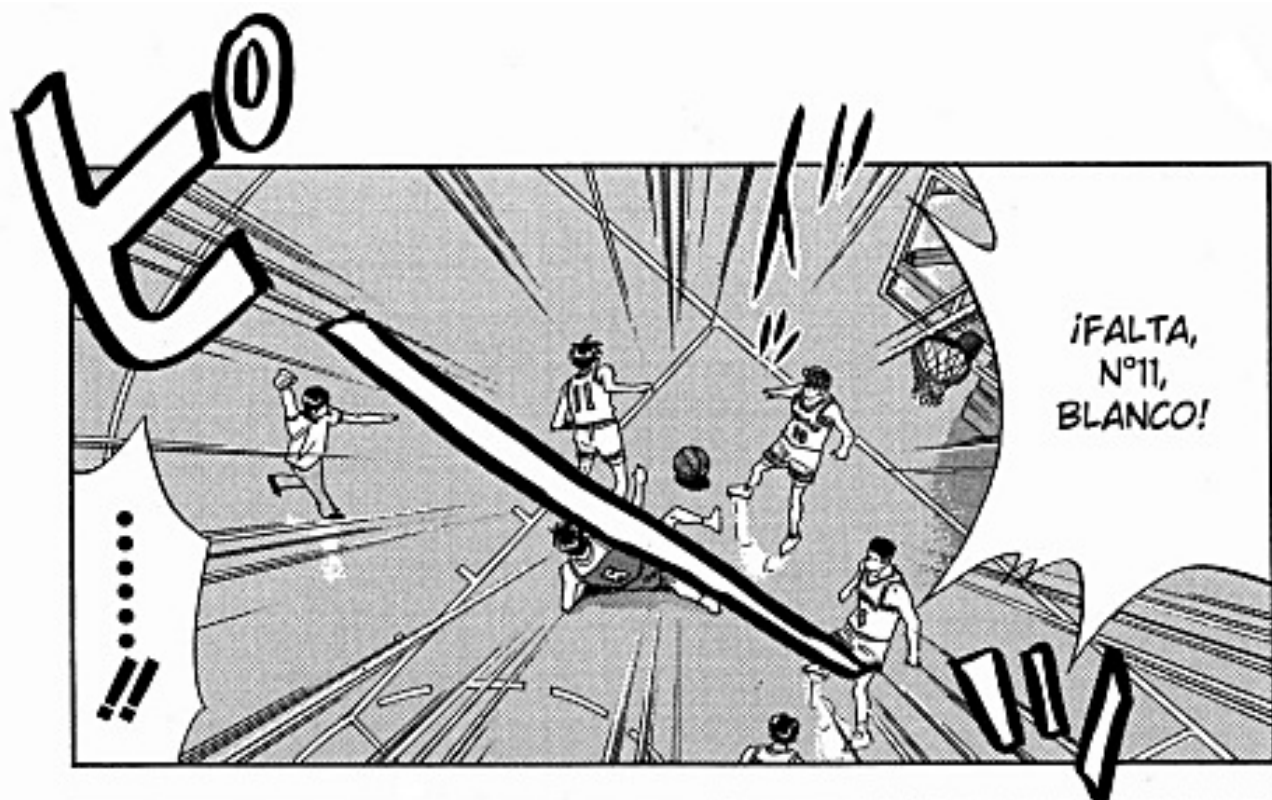



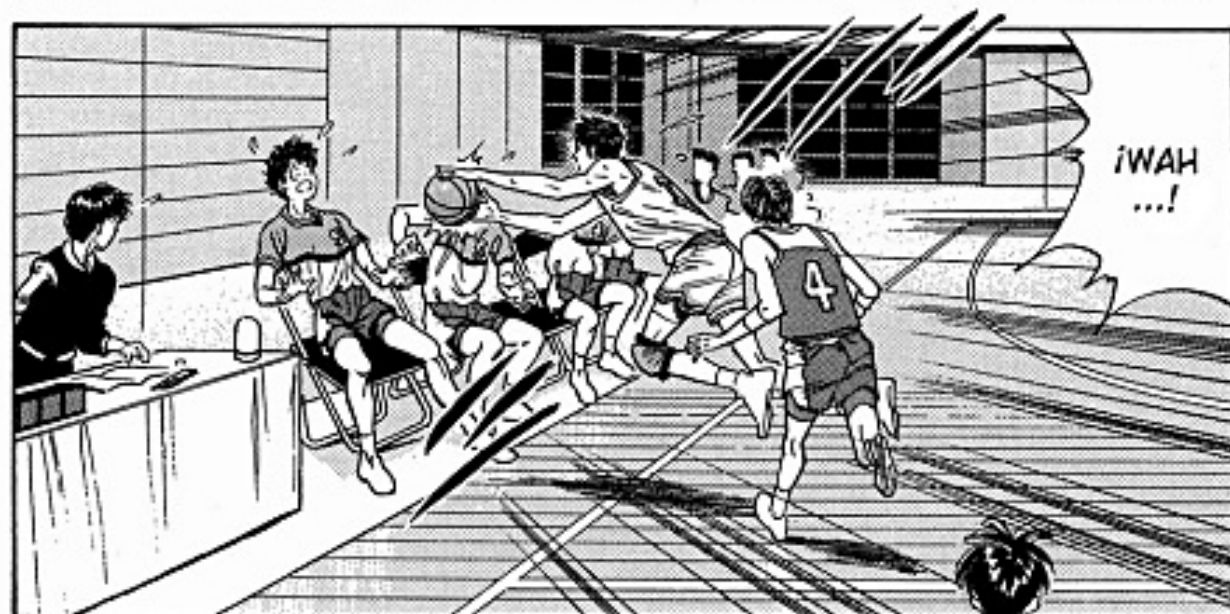





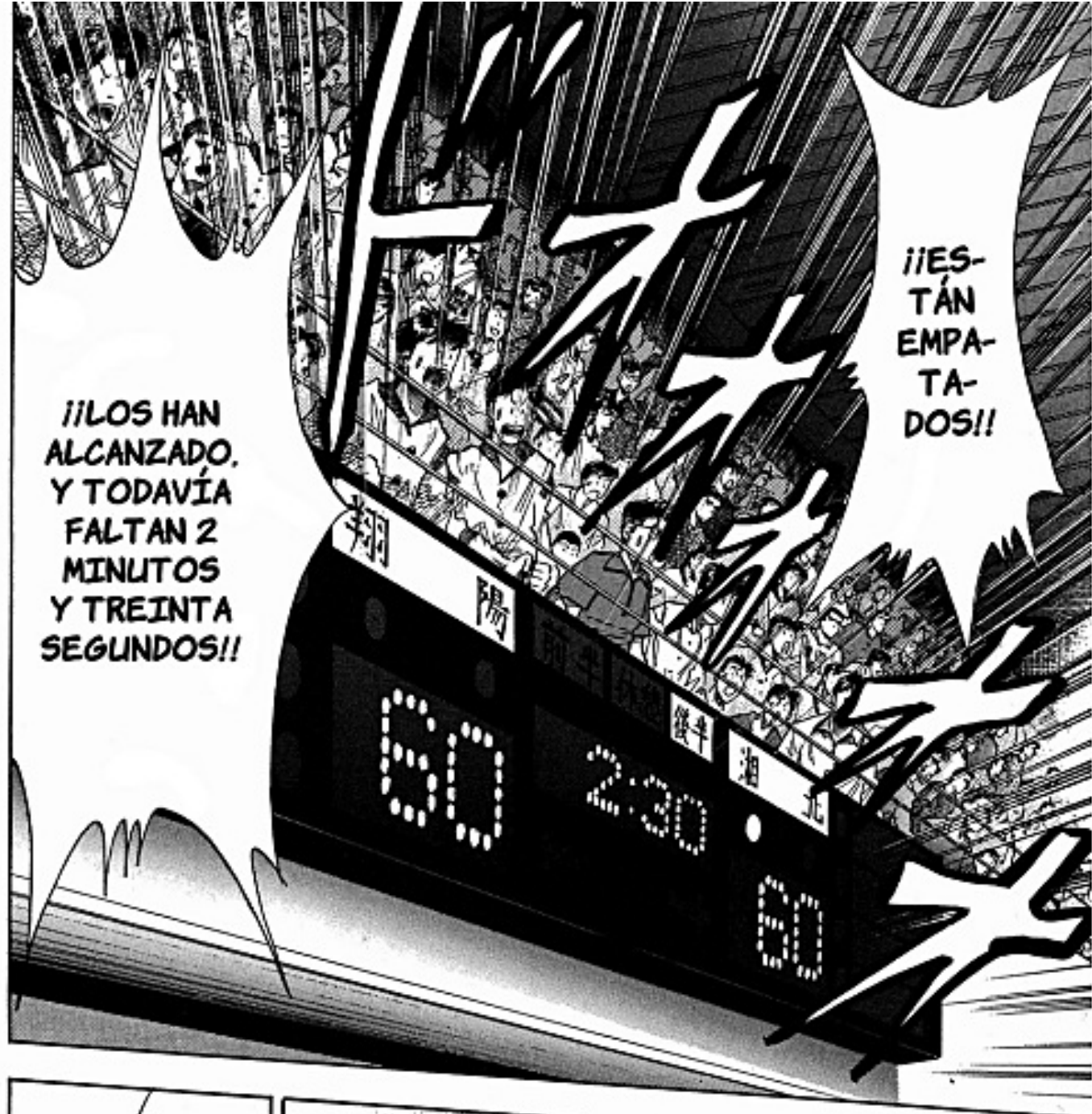

¡¡LOS HAN
ALCANZADO,
Y TODAVÍA
FALTAN 2
MINUTOS
Y TREINTA
SEGUNDOS!!

¡¡ES-
TÁN
EMPA-
TA-
DOS!!



¿POR QUÉ
TIENES
MIEDO?



¡HEY!

¿UH?



¿TE
ENCUEN-
TRAS
BIEN,
MITSUI?!

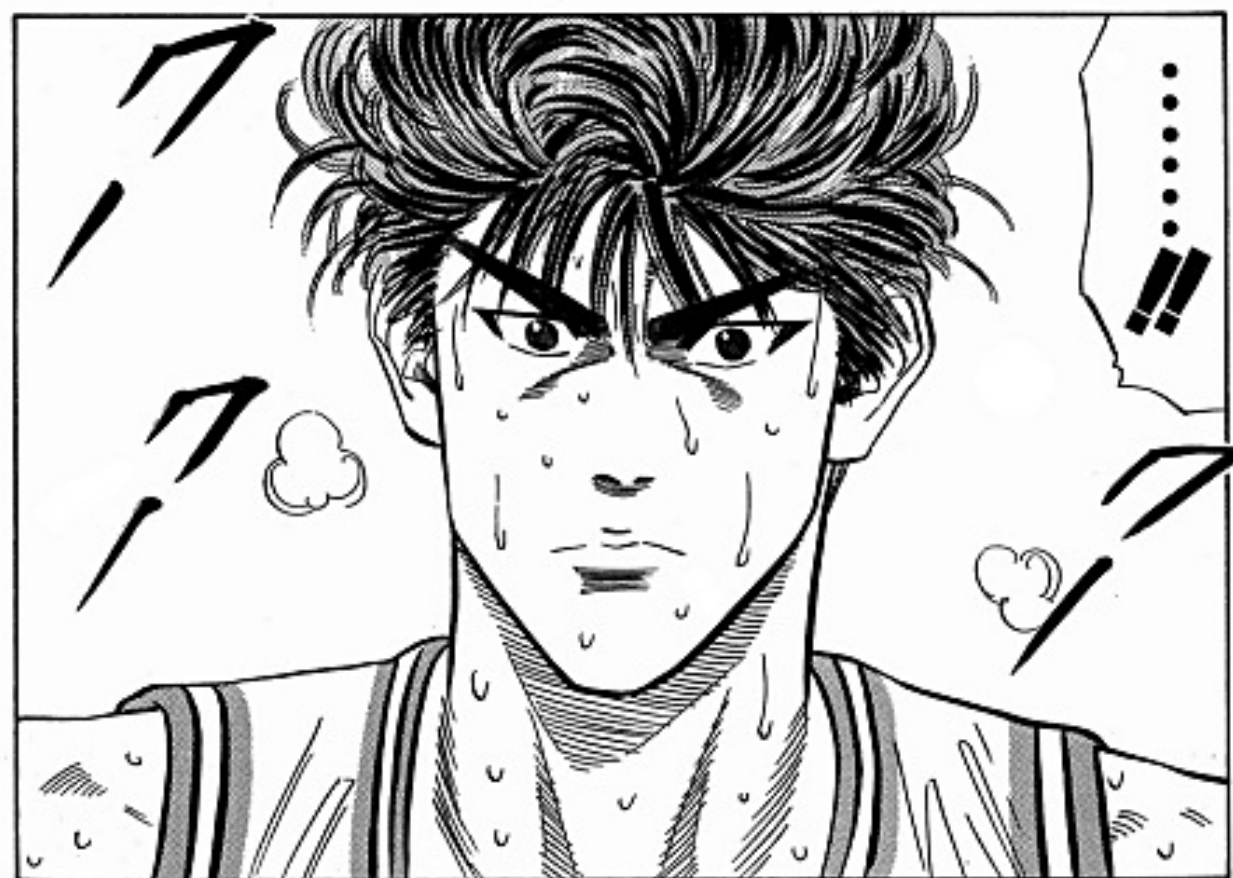

**SLAM
DUNK**

Faltan 2 minutos y medio ...

El marcador es 60 a 60.

Hisashi Mitsui finalmente deja el juego, luego de haber marcado 20 puntos (15 de los cuales, fueron triples)

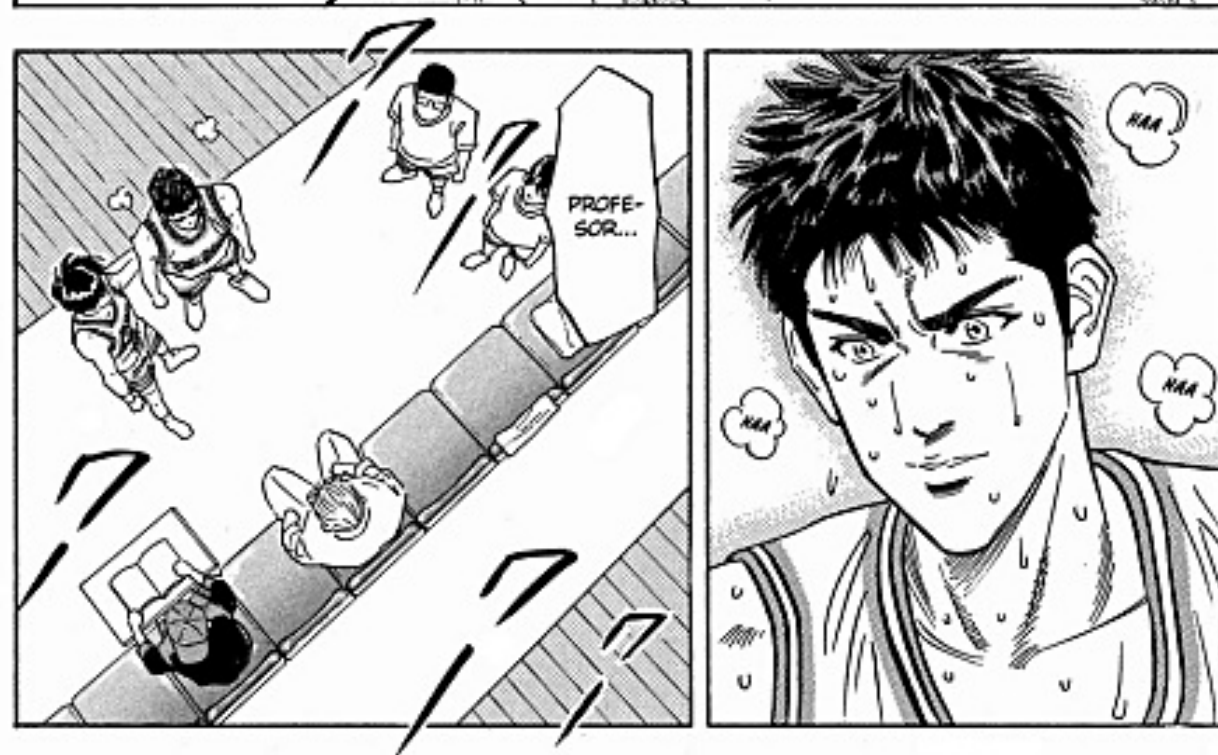
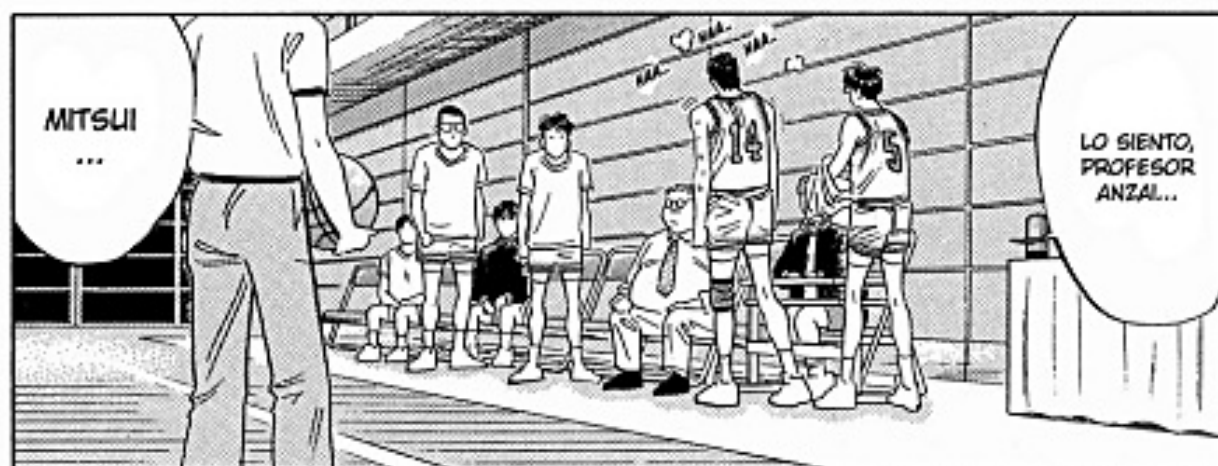

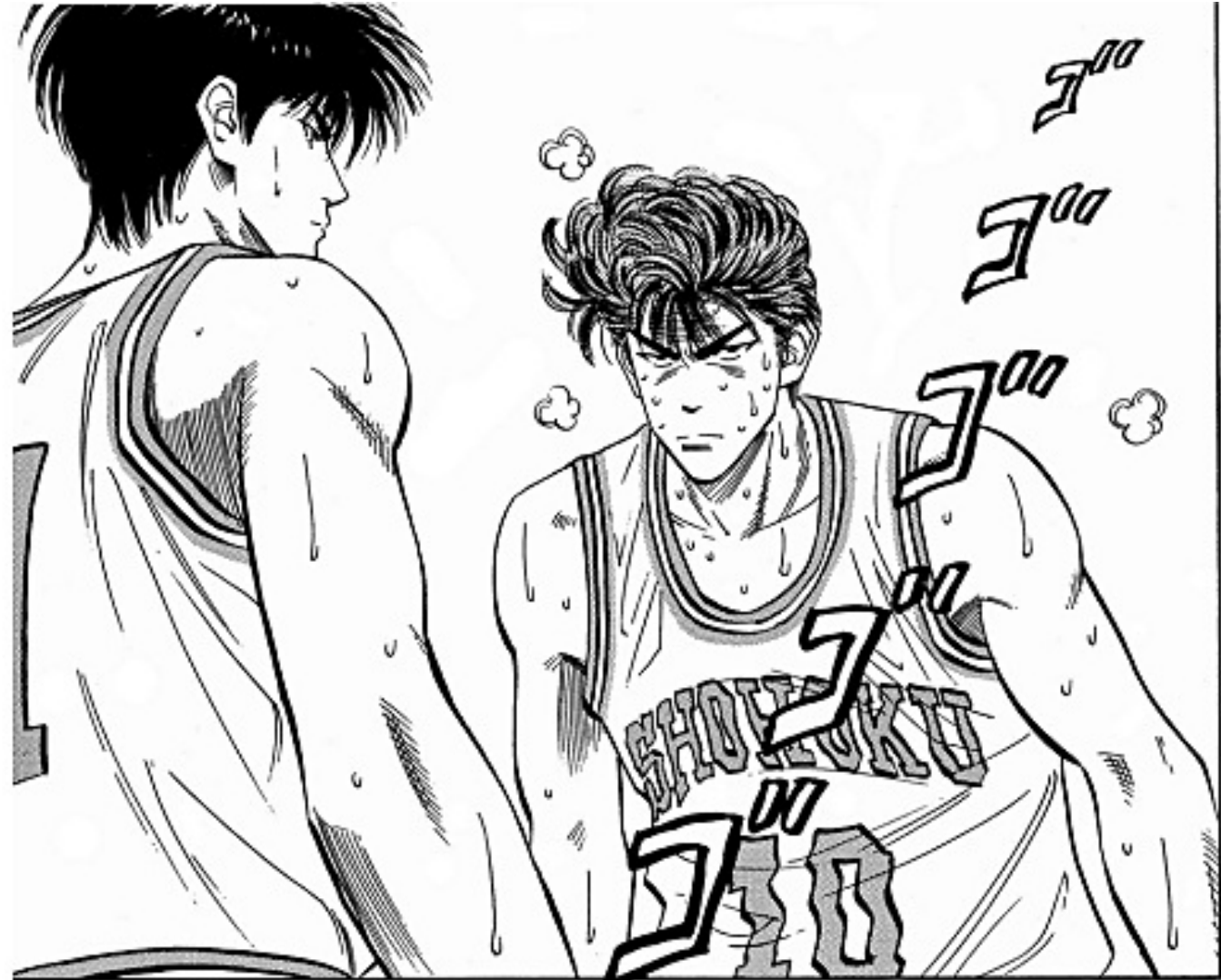

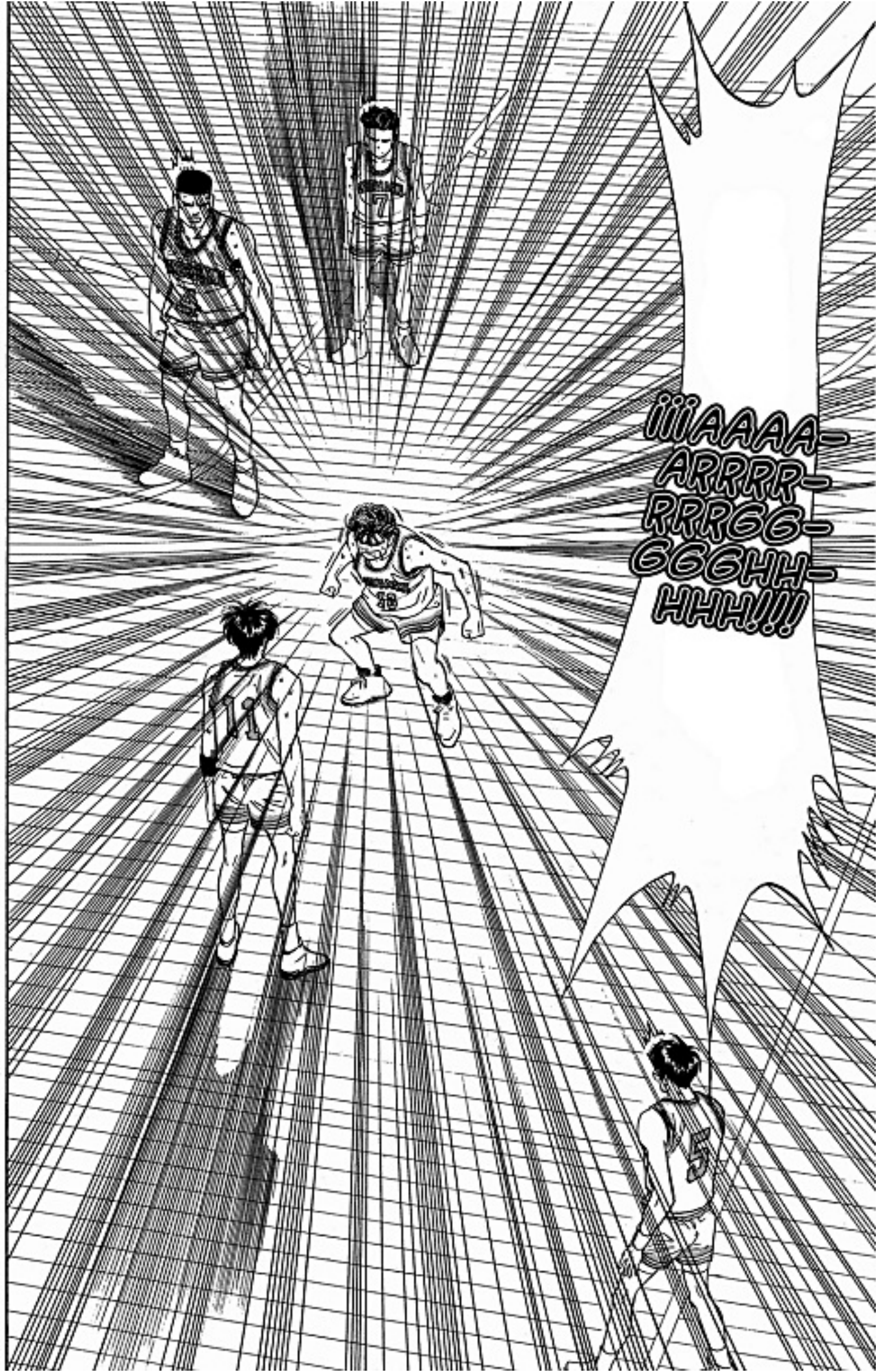

iiiAAA-
ARRRR-
RRGG-
GGHH-
HHH!!!







¡VAMOS
A GANAR
ESTE
JUEGO
A COMO
DÉ
LUGAR!

¡ARRIBA
ESE
ÁNIMO!



¿QUÉ
IMPORTA
SI TENGO
CUATRO
FALTAS?

¡YO SOY UN
GENIO,
SALDRÉ SIN
PROBLEMAS
DE ESTO!



CONSIGAN LA
VICTORIA.

LO DEJO EN
SUS MANOS.



SAKURAGI
...

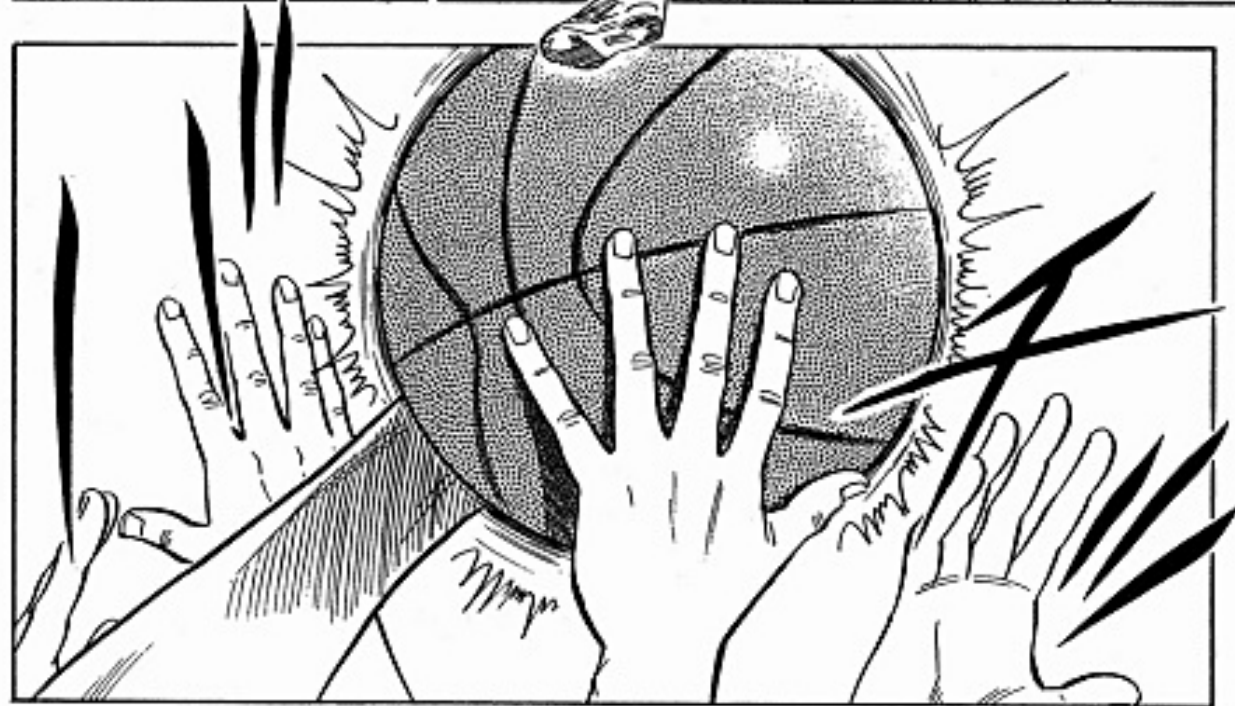







!!SHOHOKU ESTABA EN DESVENTAJA, PERO SE HA RECUPERADO Y AHORA ESTÁ GANANDO EL PARTIDO!!

¡HAN TOMADO LA DELANTERA!



ESOS DOS...

¡HAN MEJORADO MUCHO!



ESTO NO VA BIEN ...

LA SITUACIÓN HA ESCAPADO DEL CONTROL DE FUJIMA ...



¡LOS REBOTES DE SAKURAGI, LAS JUGADAS DE RUKAWA!

¡ESTE DÚO DE NOVATOS!



TÚ ERES
EL QUE
HACE ESO

¡DEJA DE
TRATAR DE
LUCIRTE,
ESTÚPIDO!



¡HAM!

!!



¡SOY UN
GENIO,
NO SIENTO
MIEDO!

¿QUÉ NO
TIENES
MIEDO
DE SER
EXPUL-
SADO?!



¡RAYOS!
¡FUJIMA!





¡¡TÚ
PUEDES,
HANAMI-
CHI!!



¡MIRA
BIEN ESTO,
RUKAWA!

HAA...

HAA...

HAA...

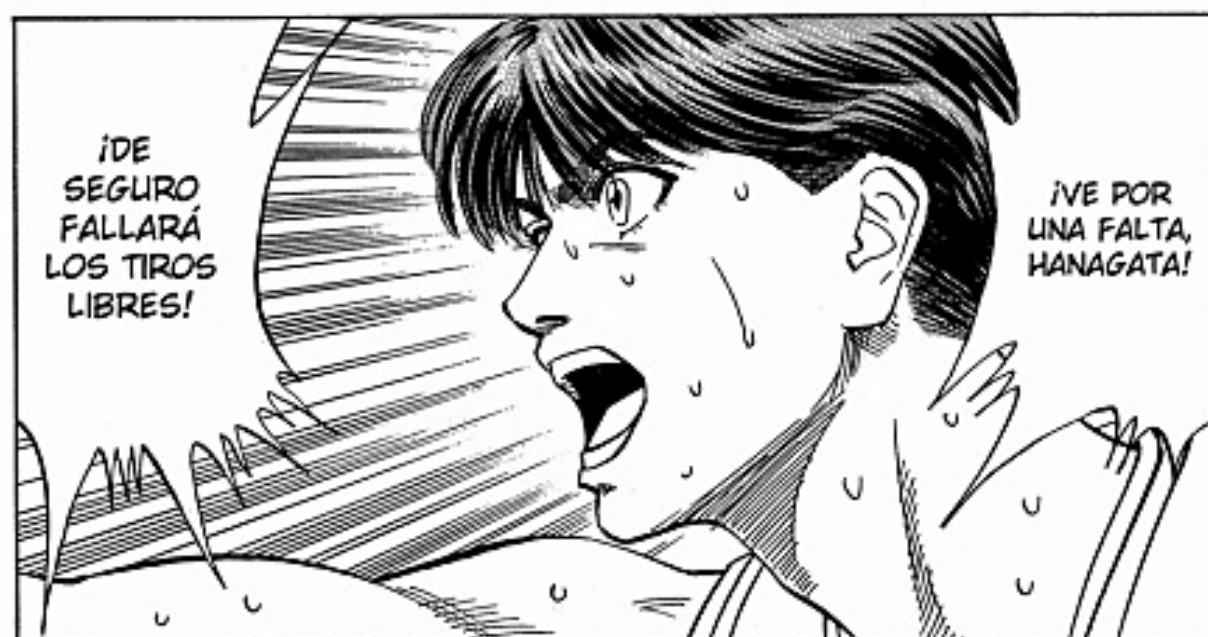

¡DE
SEGURO
FALLARÁ
LOS TIROS
LIBRES!

¡VE POR
UNA FALTA,
HANAGATA!



!!UUA AAA-
AAHHH!!

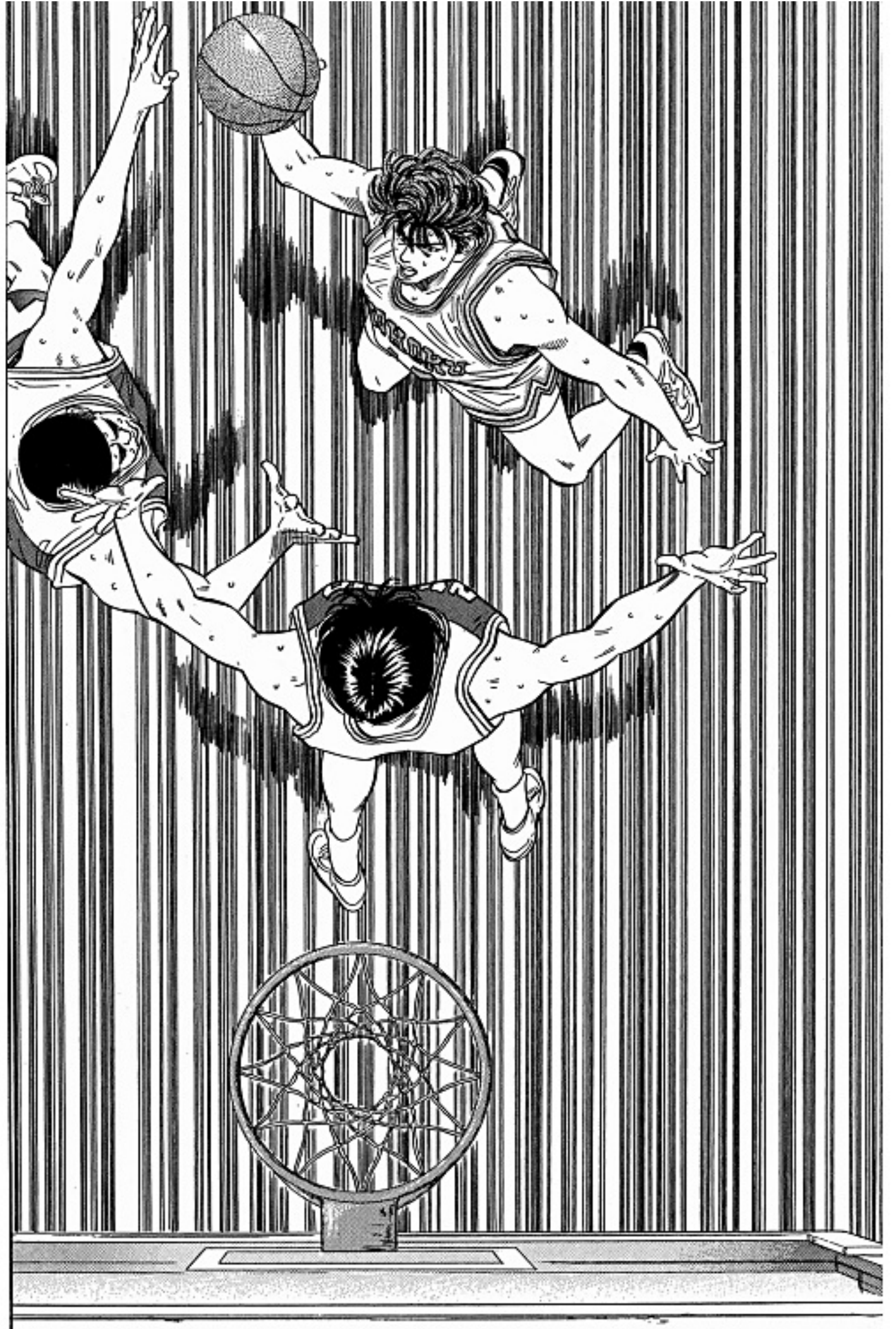

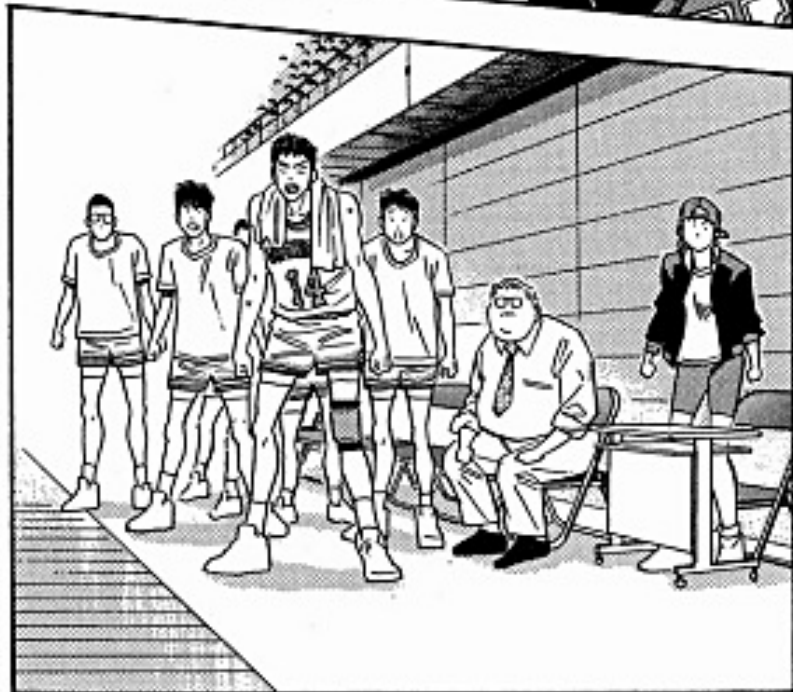
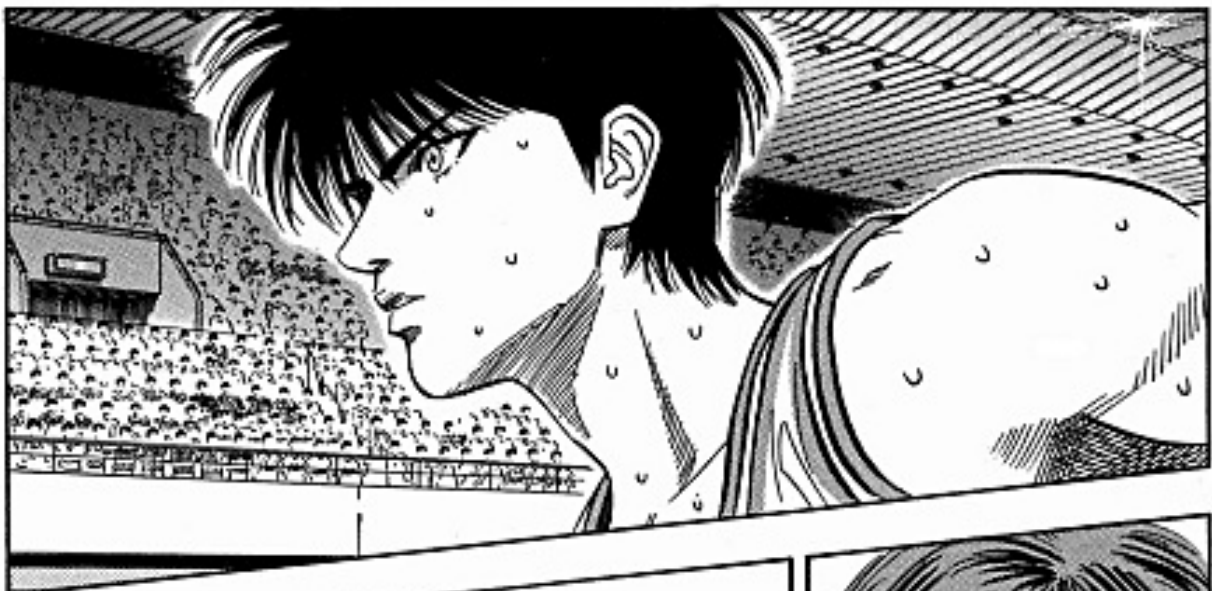



**SLAM
DUNK**



capítulo 97:
aunque sólo haya
sido suerte



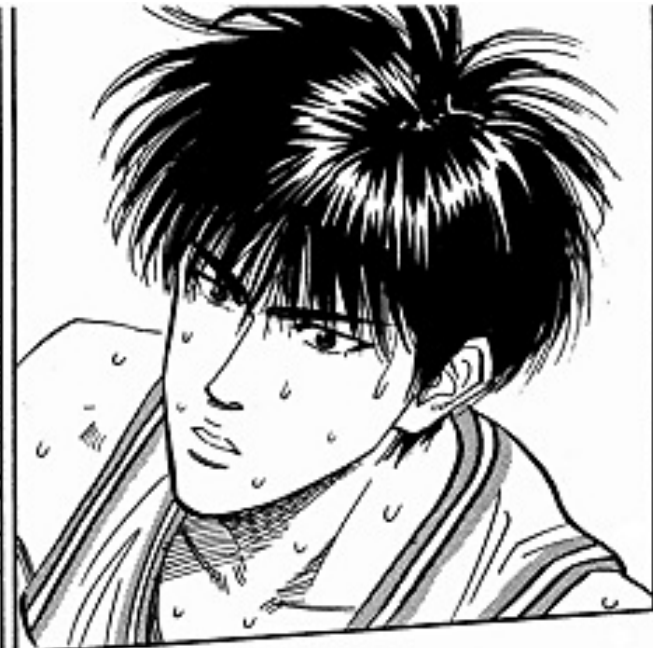



!!SAKU-
RAGI!!

!!OOOOHHH-
HHHHHHH!!



¡LA
CANASTA
NO VALE!

¡FALTA!

¡¿Q--
QUÉ?!

Faltando
1 minuto,
50 segundos
para que
termine el
partido

Hanamichi
Sakuragi es
expulsado







¡ÉL ES REAL-
MENTE INCREÍ-
BLE!

¡LO
SABÍA!

¡JUSTO
COMO LO
PENSABA!

¡ES
ALGUIEN
A QUIEN
SE LE DEBE
PRESTAR
MUCHA
ATENCIÓN!



¡EL REY
DE LOS
REBOTES!

¡SAKU-
RAGI!



¡SAKU-
RAGI!

¡ESO FUE
ASOMBRO-
SO...!

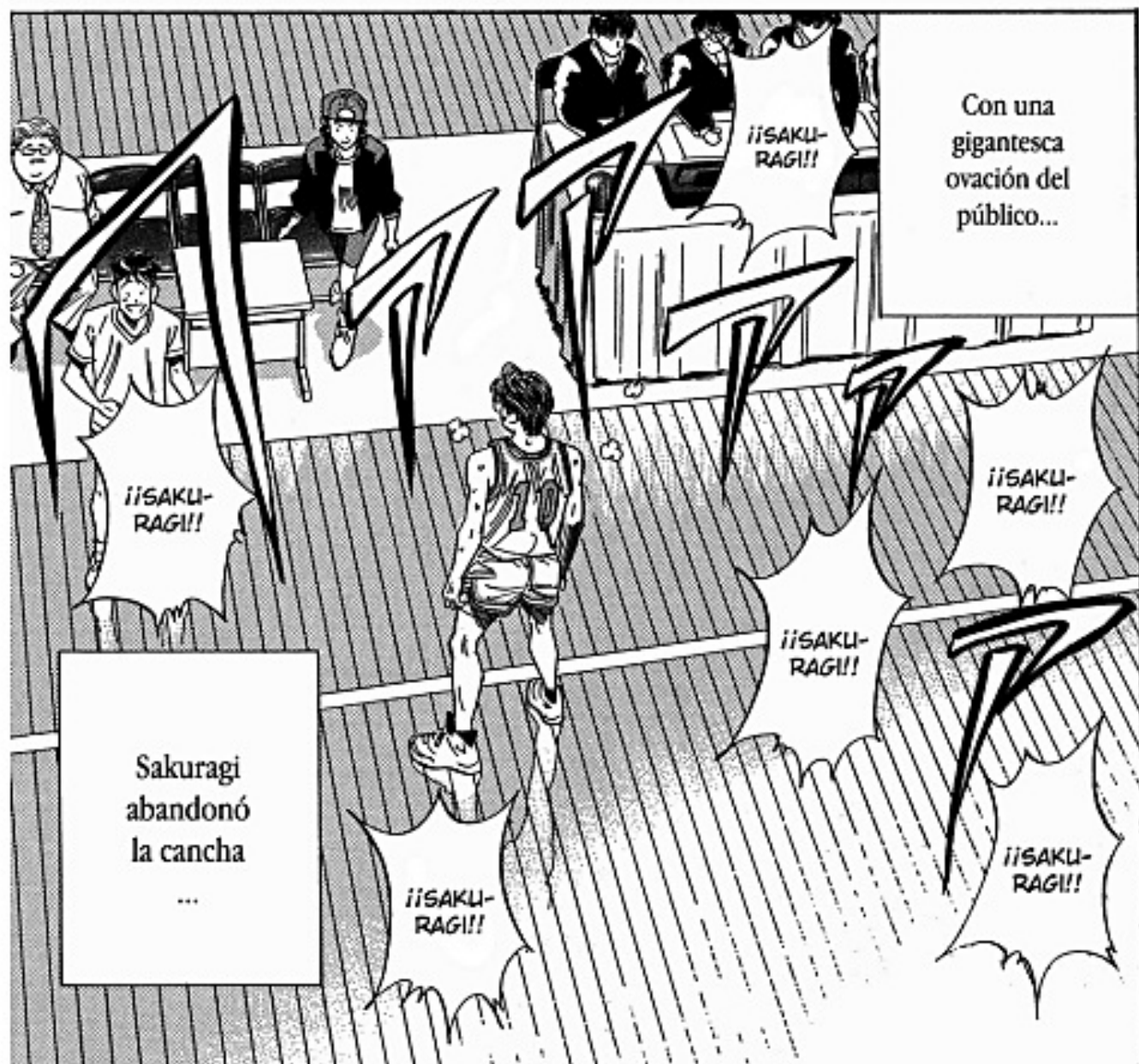

Con una
gigantesca
ovación del
público...

Sakuragi
abandonó
la cancha
...

¡¡SAKU-
RAGI!!

¡¡SAKU-
RAGI!!

¡¡SAKU-
RAGI!!

¡¡SAKU-
RAGI!!

¡¡SAKU-
RAGI!!

¡¡SAKU-
RAGI!!

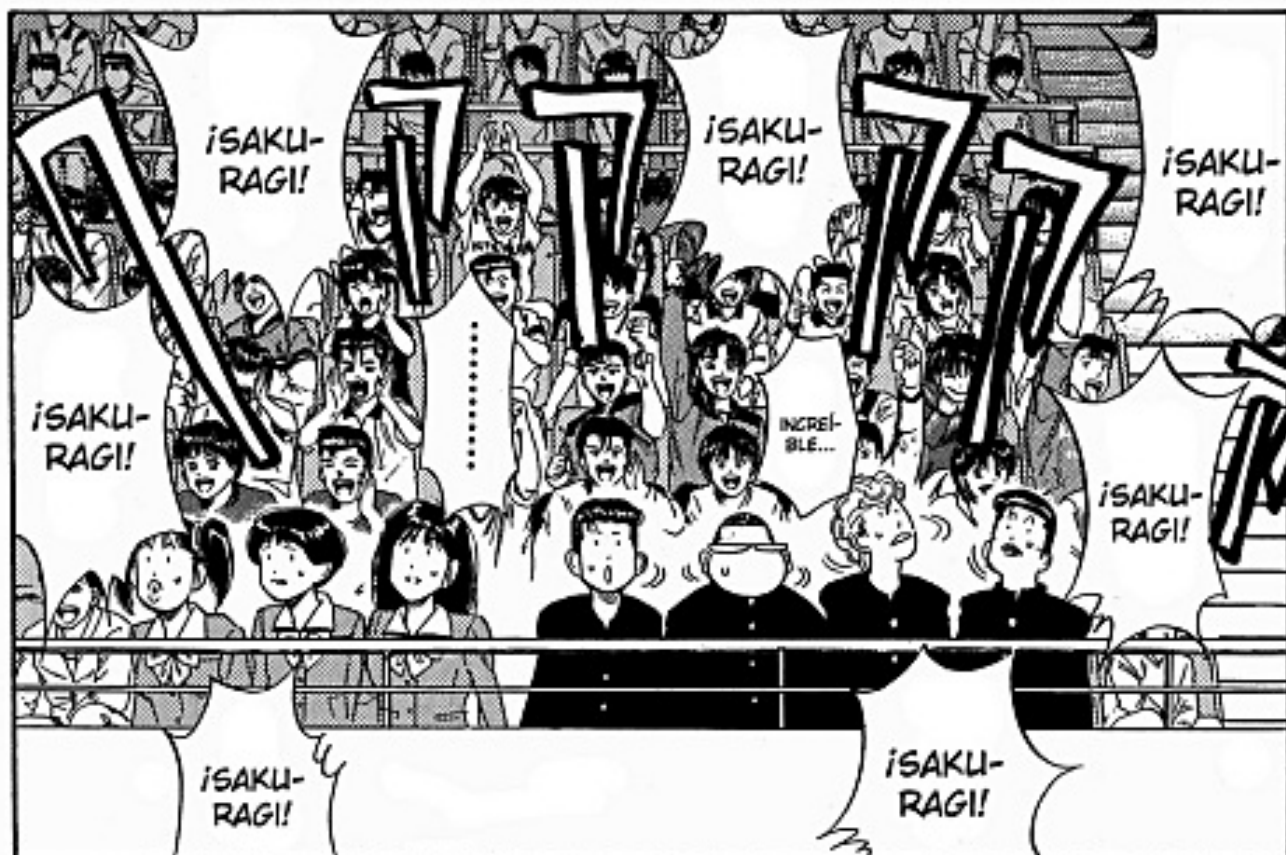

TE VUELVES
ALGUIEN MÁS
INCREÍBLE...



CADA DÍA
QUE PASA...



SUPERASTE
TODAS MIS
EXPECTATIVAS

SAKURAGI...

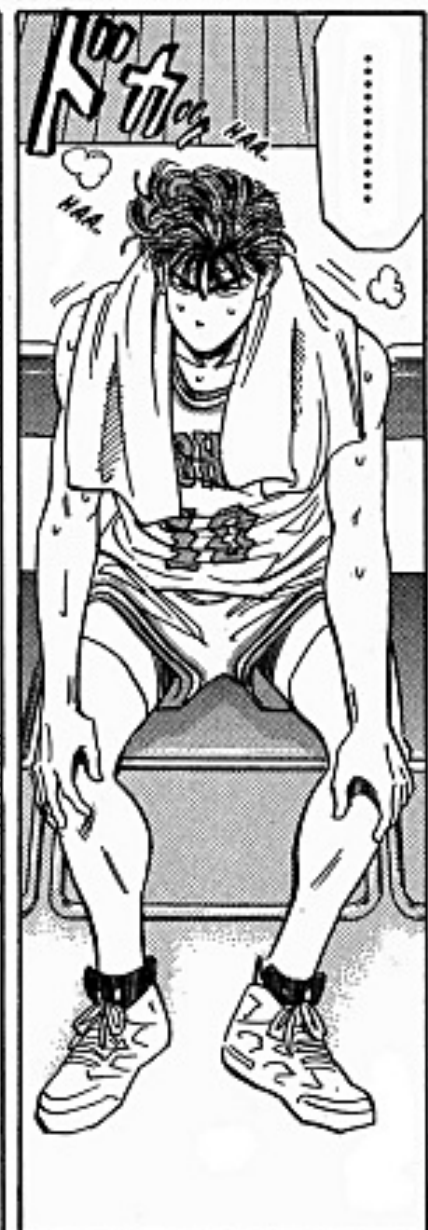



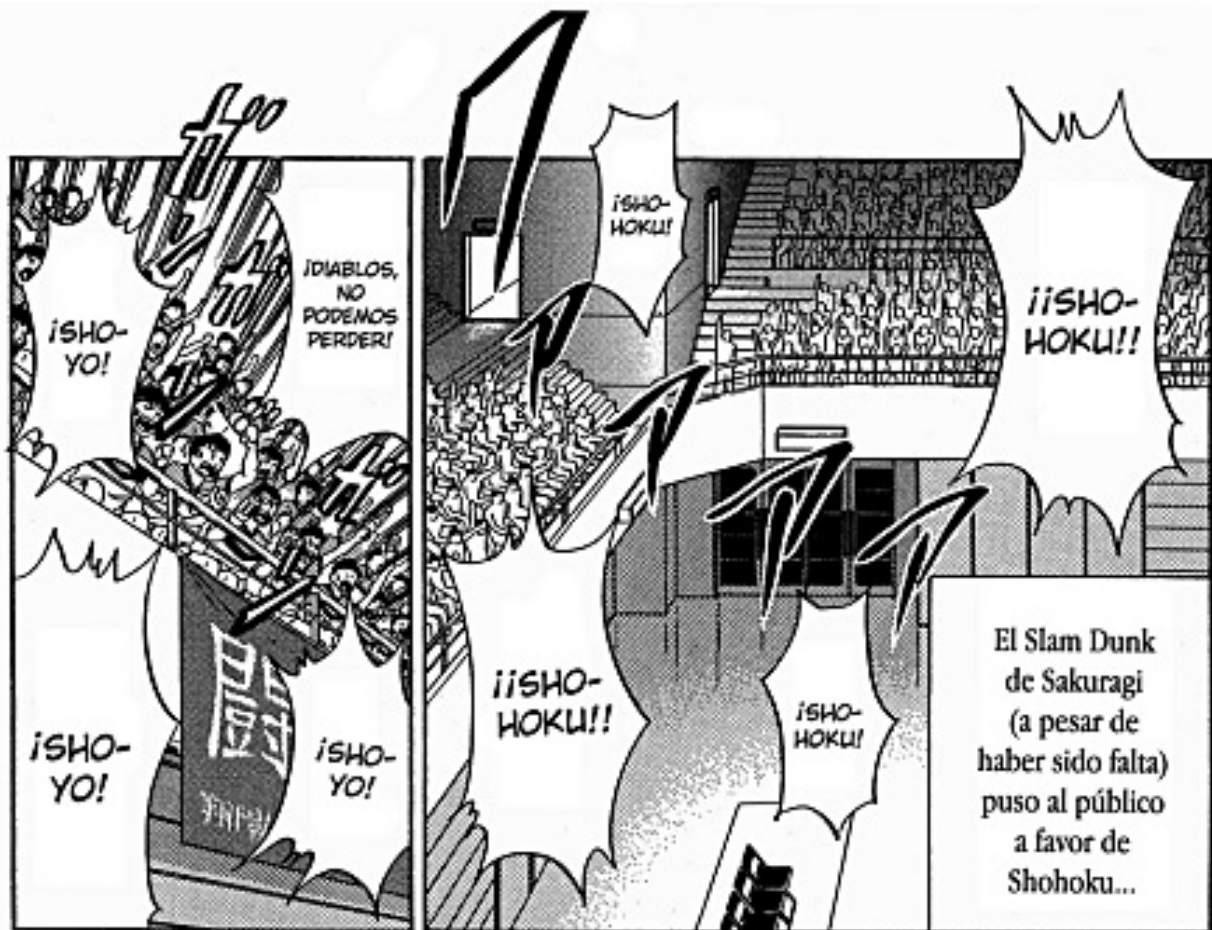

El Slam Dunk de Sakuragi (a pesar de haber sido falta) puso al público a favor de Shohoku...





!!SHOYO FUE
DEROTADO!!

¡EL JUEGO
TERMINÓ!



Shohoku
usó toda
la fuerza que
le quedaba
...

para
resistir
los 1:50
que
quedaban
...

Aunque Shoyo, que
era el segundo
mejor equipo de la
prefectura, dio todo
lo que tenía en la
cancha, no pudo
superar a Shohoku
...

**¡¡GANA-
MOS!!**

**¡ESTAMOS
EN LAS
FINALES!**





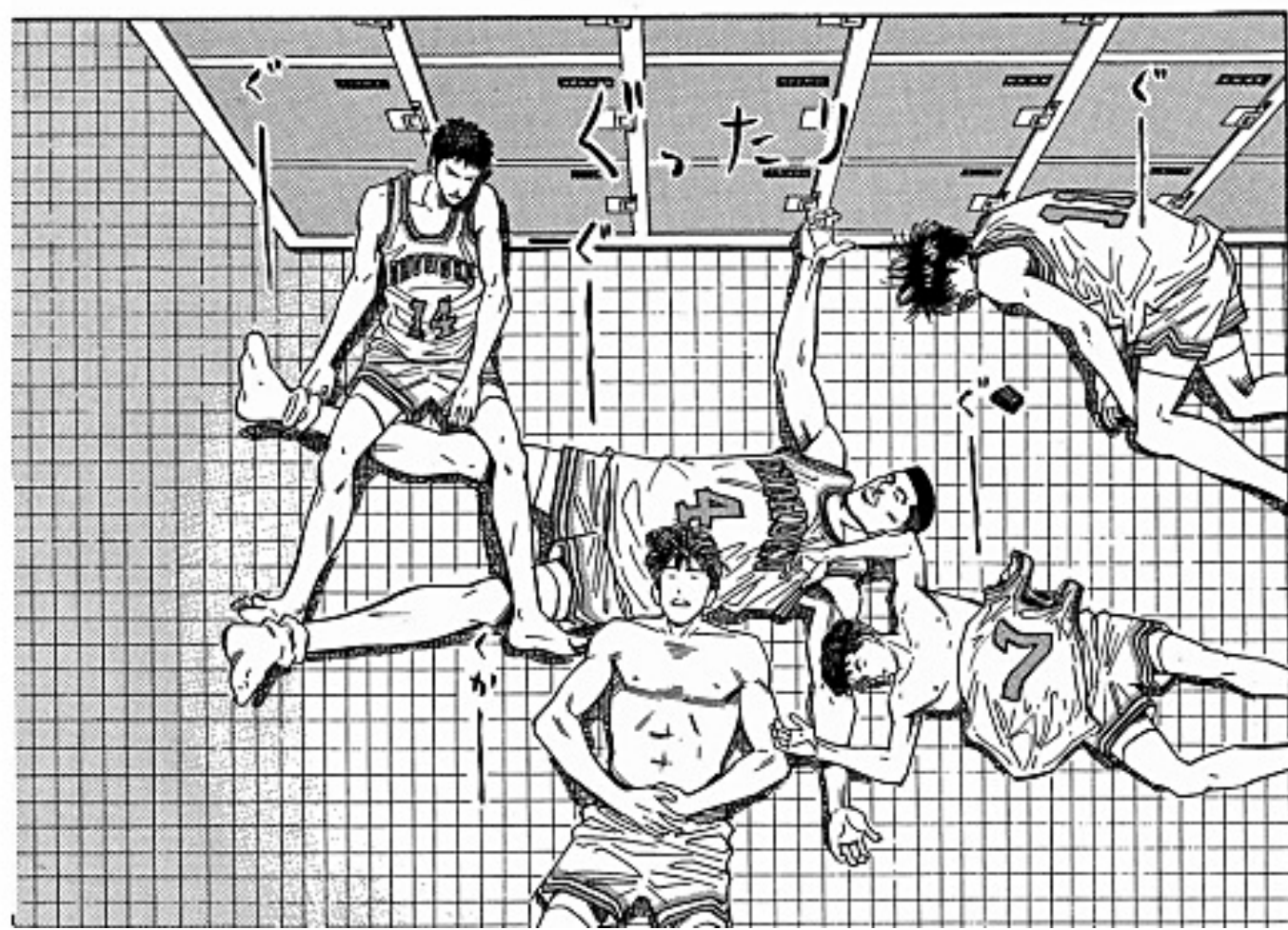

**SLAM
DUNK**

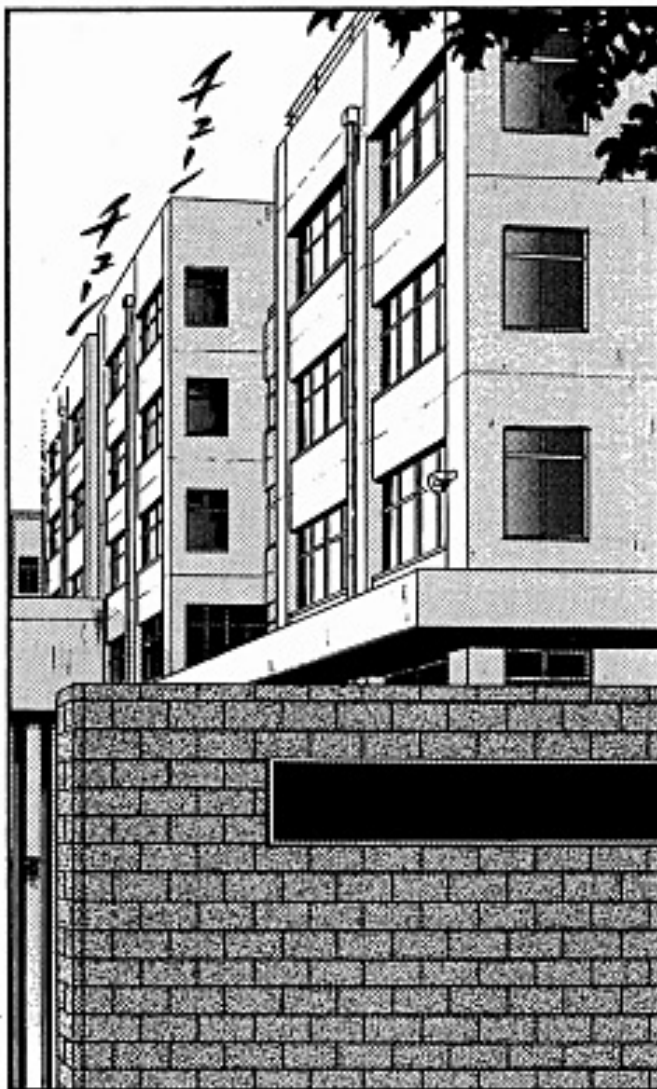
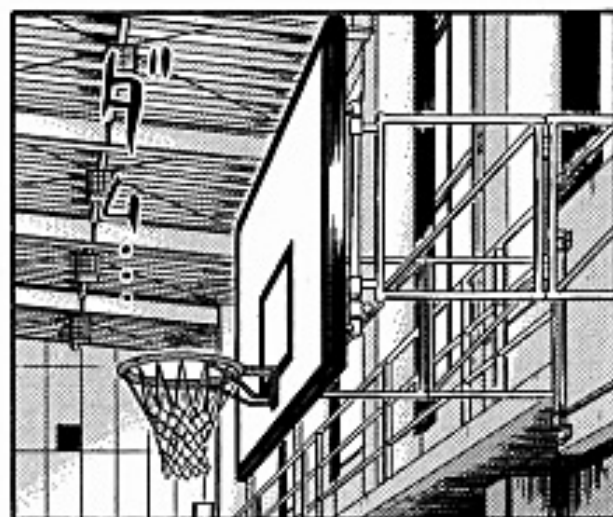
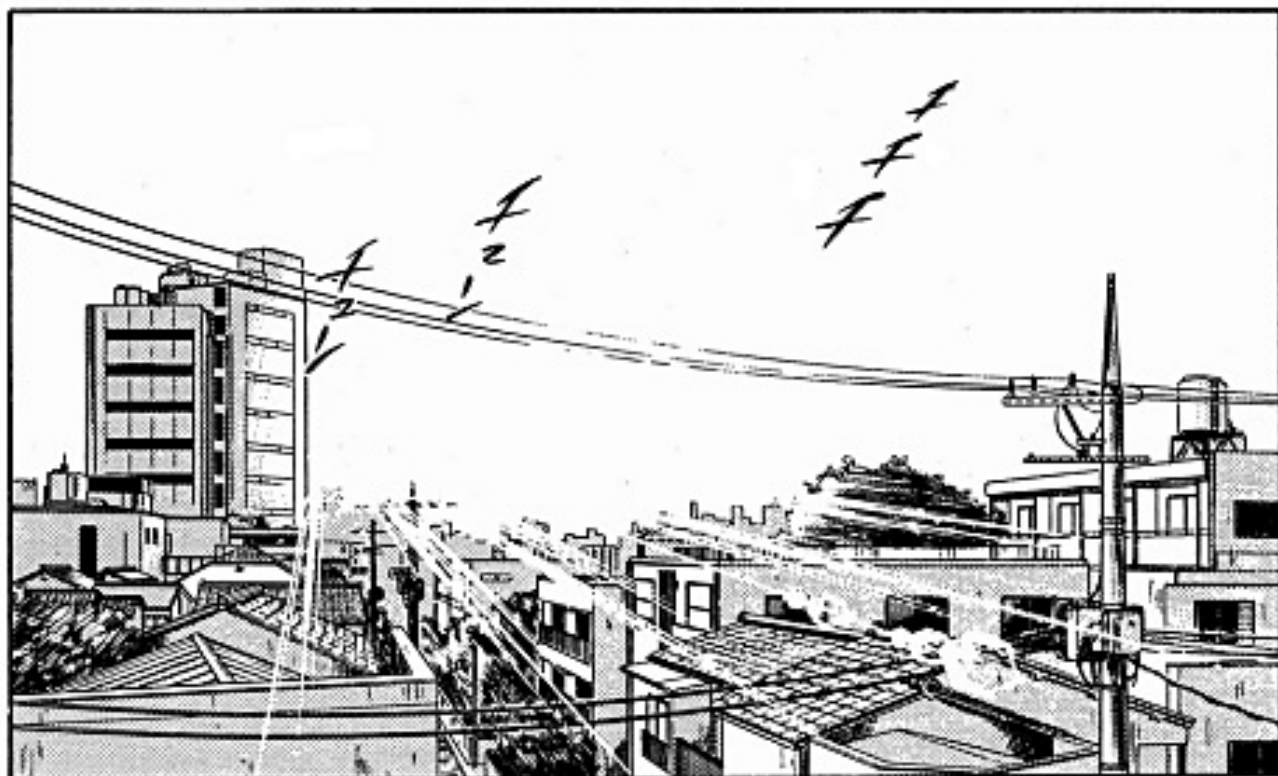

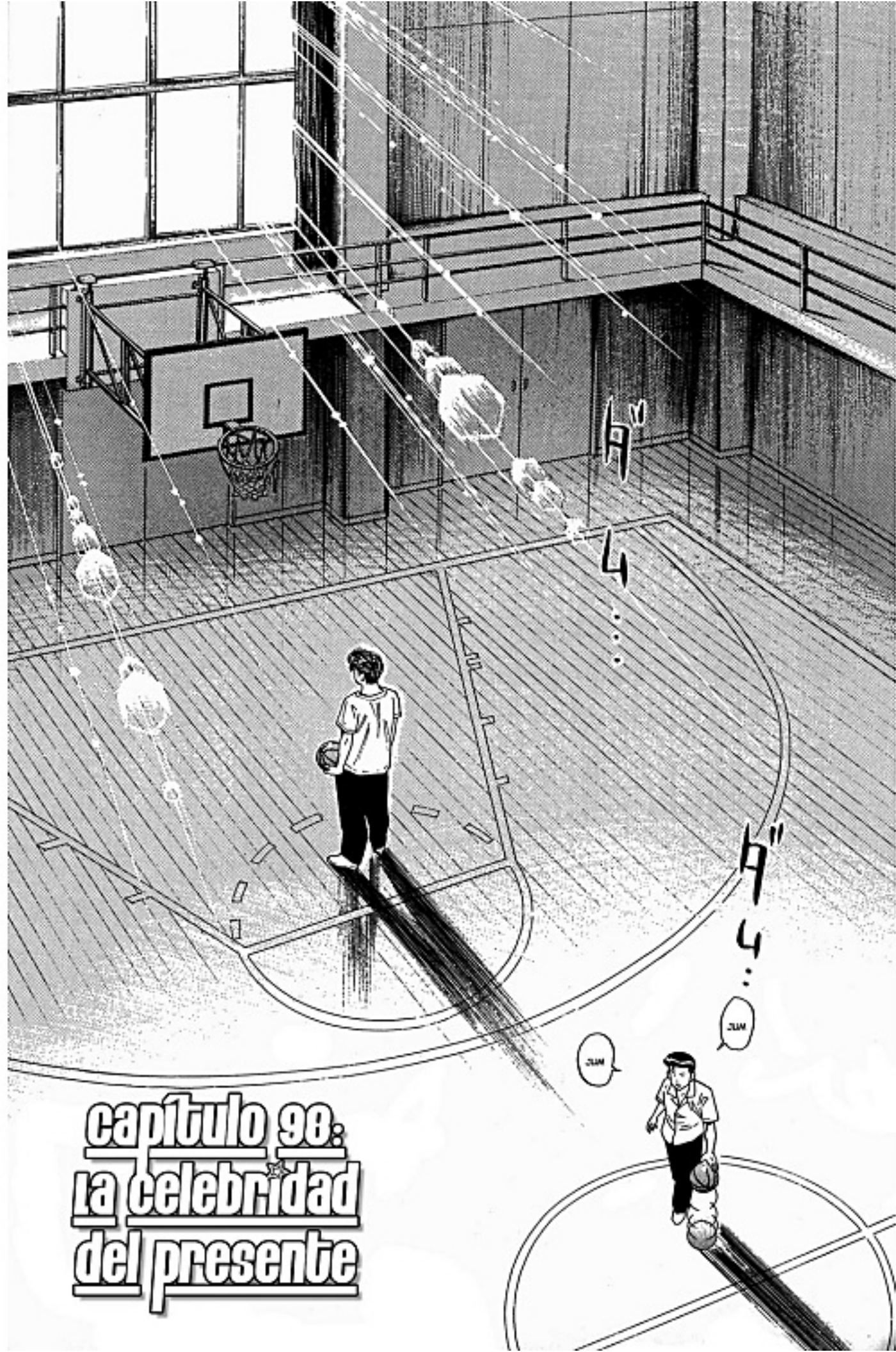

capítulo 98:
la celebridad
del presente





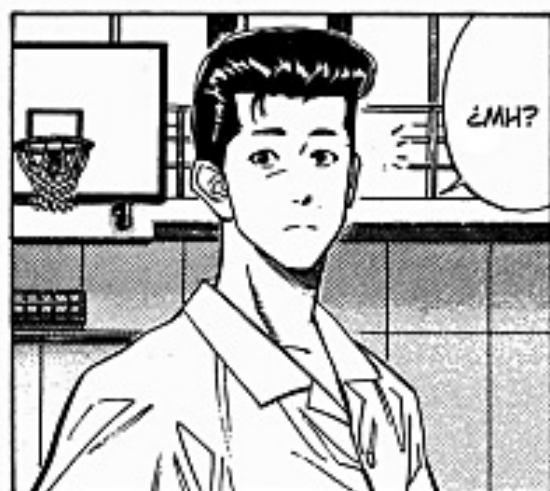



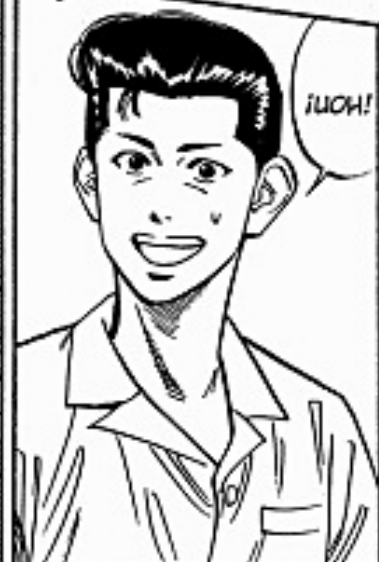
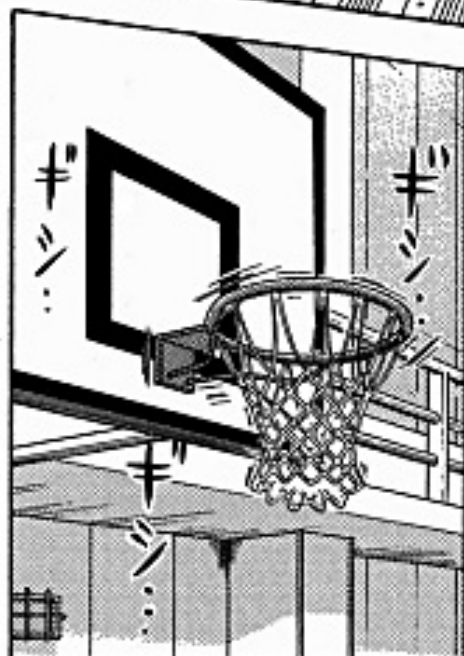

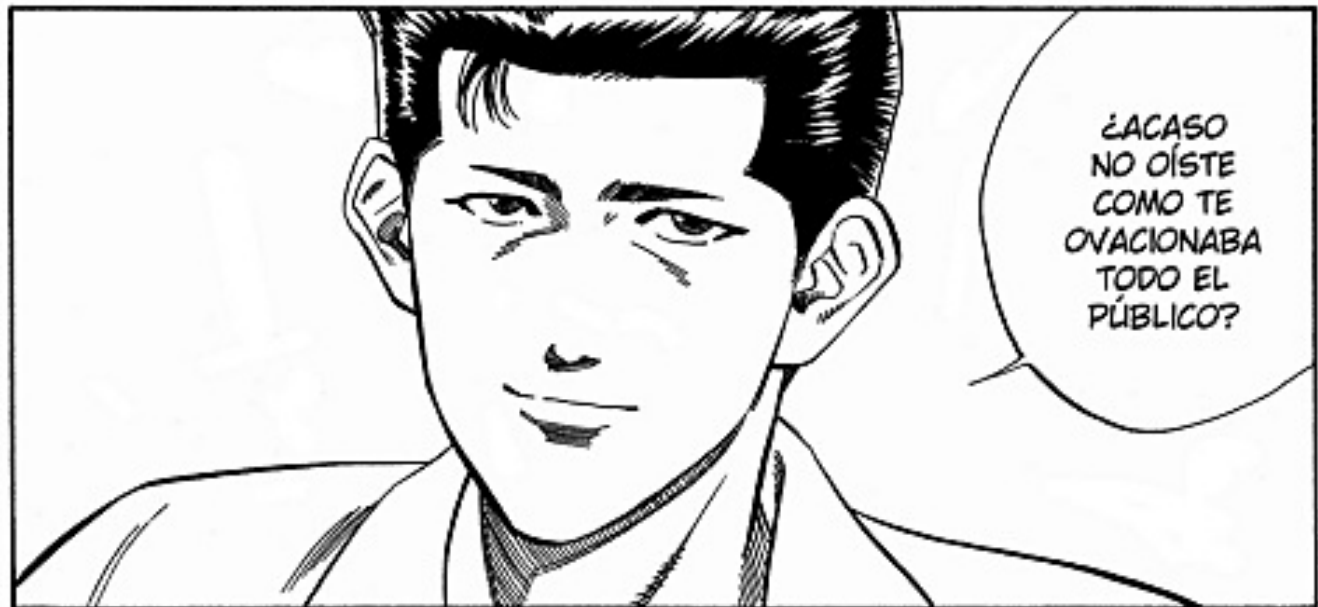
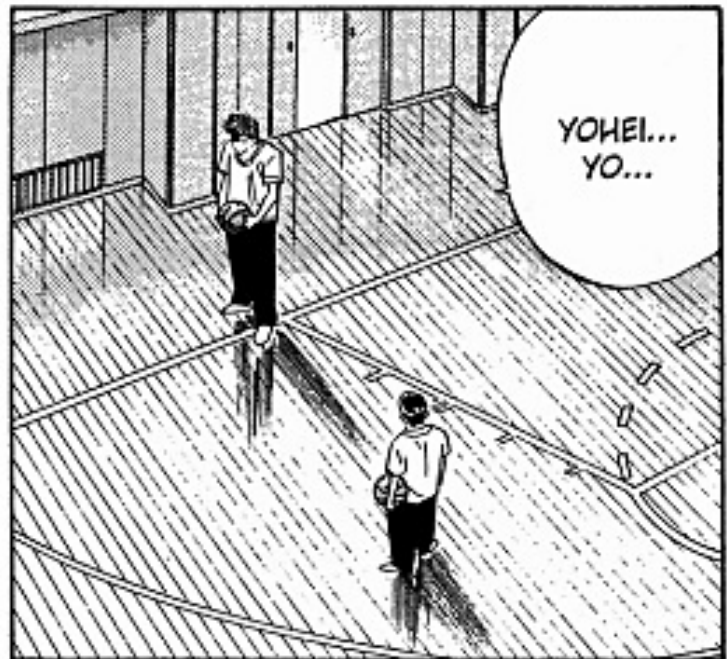



FINALMENTE
MEJORÉ UN
POCO...

CREO
QUE...



¡JA
JAJA
JAJA
JA!

¡CLARO
QUE
SOY UN
GENIO!



PORQUE
ERES UN
GENIO

¡JAJA
JA!



¡JA...!



¡HARUKO!

Y TAMBIÉN
EL GORRO...

¡AH!

¿EH?

¿ME VISTE
JUGAR AYER,
HARUKO
...?

TÚ
TAMBIÉN
VINISTE
TEMPRANO
...

YO
SIEMPRE
VENGO
TEMPRANO

¿QUÉ HACES AQUÍ
TAN TEMPRANO
POR LA MAÑANA?
¿TRATAS DE
COMPENSAR EL
HECHO DE HABER
COMETIDO 5 FALTAS
Y HABER SIDO
EXPULSADO?

¡ADEMÁS,
DESPUÉS DE
LEER EL
PERIÓDICO
ESTA MAÑANA,
DEBES ESTAR
MUY EMOCIO-
NADO POR
EL PARTIDO!

¡DE SEGURO
TRATA DE
ESTAR LISTO
PARA LAS
FINALES!





¿LO CREES?
CIERTAMENTE,
EL QUE UN CHICO
QUE VA A NUESTRO
MISMO INSTITUTO
HAYA SALIDO EN
EL PERIÓDICO ME
EMOCIONA MUCHO

¡OH, ASÍ QUE
SALIÓ EN EL
PERIÓDICO!

¡EN
VERDAD
ES UNA
CELEBRIDAD!



JEJEJEJE...

¿AH, SÍ?



¿QUÉ
DIJERON.
IDIOTAS?!

¡¡AH, ES
LA CELEBRIDAD!!



PARECE
QUE NO ERA
SÓLO UN
IDIOTA
DESPUÉS
DE TODO...

¡SÍ, NO
SABÍA QUE
PODÍA JUGAR
AL BASKET
...





DAN UN POCO DE MEDO..

ESAS CINCO PERSONAS FORMAN EL EQUIPO QUE LLEGÓ A LAS FINALES...

¡TIENEN UNA APARIENCIA MUY INTIMIDANTE!

IRUKAWA!

SON LOS TITULARES DEL EQUIPO DE BASKETBALL...



¡¡ÁNIMO, EQUIPO!!

¿EH?

**¡AKAGI!
¡ESTE AÑO SEGURO GANAREMOS EL TORNEO INTERCOLE-GIAL!**

¡ESTE AÑO DE SEGURO GANARÁN!



